

EasyStart

364 (3 ton) Soft Starter
368 (6 ton) Soft Starter

Installation Manual

Micro-Air Corporation
124 Route 526
Allentown NJ 08501

www.microair.net
Phone (609) 259-2636
Fax (609) 259-6601

Retrofit Instructions:

1. Read and understand these instructions completely before proceeding. Improper wiring can result in damage to EasyStart or connected components including but not limited to wiring, compressors, and capacitors. ***Micro-Air Corp is not responsible for damages to any of the aforementioned equipment caused by improper wiring.***
2. Turn off the breaker for the compressor's electrical system.
3. Identify an appropriate location for EasyStart that allows mounting with the EasyStart wire exit pointing down. Securely mount the EasyStart box and route the wiring into the existing run capacitor location. Be sure to secure the harness to prevent vibration or movement damage.
4. Consult the manufacturers installation manual and wiring diagram for the identification of the following:
 - a. Compressor R, C, and S terminals and associated wire color for each connection. Compressors have a plastic cap with a single hex nut covering the connections. Wires can usually be identified without removing this cover however the cover or markings near the terminals can also be used to identify the wires.
 - b. Run capacitor (typically in a metal can). This capacitor will have 2 or 3, multi-point terminal group connections.
 - c. Control board switched-L1 output or main contactor compressor L1 output connecting to the compressor common 'C' terminal wire. Note some systems utilize a contactor to switch power to the compressor, other use a power relay integrated into the main control board.
5. Identify the wire color connected to the compressor "S" terminal and follow the wire to the run capacitor. Disconnect any other wire connected to the same terminal group. Follow the disconnected wire and remove it from the connector on other end. If the wire goes into a PTC device simply follow the second wire coming from the device, disconnect it and remove the PTC. Not all systems will have a second wire on this terminal group.
6. Connect the orange wire from EasyStart to the same terminal group identified in step 5.
7. Locate the wire connected from the compressor run winding 'R' terminal to the run capacitor 'C' terminal, and disconnect it from the run capacitor. Connect (splice) the brown wire from EasyStart to the disconnected wire.
8. For compressors under 3 tons (36 KBTU), connect the white wire from EasyStart to the same terminal of the run capacitor from which you disconnected the (white) run winding 'R' wire in step 7 above. For all other compressors, splice the white wire to the L2 wire that feeds the run capacitor or connect it to the L2 connection at the contactor.
9. Connect the black wire from EasyStart to the switched-L1 connection coming from the main control board or main contactor that typically has a black or purple wire that connects to the compressor common © terminal wire.
10. Wiring is now complete. Close all open electrical boxes and panels.
11. Turn on the system circuit breaker using shore power. Start a heating or cooling cycle with the thermostat.
12. EasyStart will now learn the characteristics of the compressor for the next five starts. This operation can be done during normal operation and does not require any intervention or special actions. Once the learning process is completed, the EasyStart can be operated on either shore or generator power. You must wait five minutes after the compressor stops for the compressor to restart. See "Anti-Short Cycle Timer" for details.

IMPORTANT INSTALLATION NOTE FOR CRUISAIR® MARINE CUSTOMERS ONLY:

When installing EasyStart into 230V SMX control applications that use the triac to switch power to the compressor, it is necessary to replace the triac with a relay. If the triac is not replaced, the pump relay triggers may suffer damage and ultimately fail. Please note that this is not required for 115V SMX applications and the triac is still safe to use. Visit the Micro-Air website or contact Micro-Air for details on the appropriate relay.

Example EasyStart Installation Wiring Diagram:

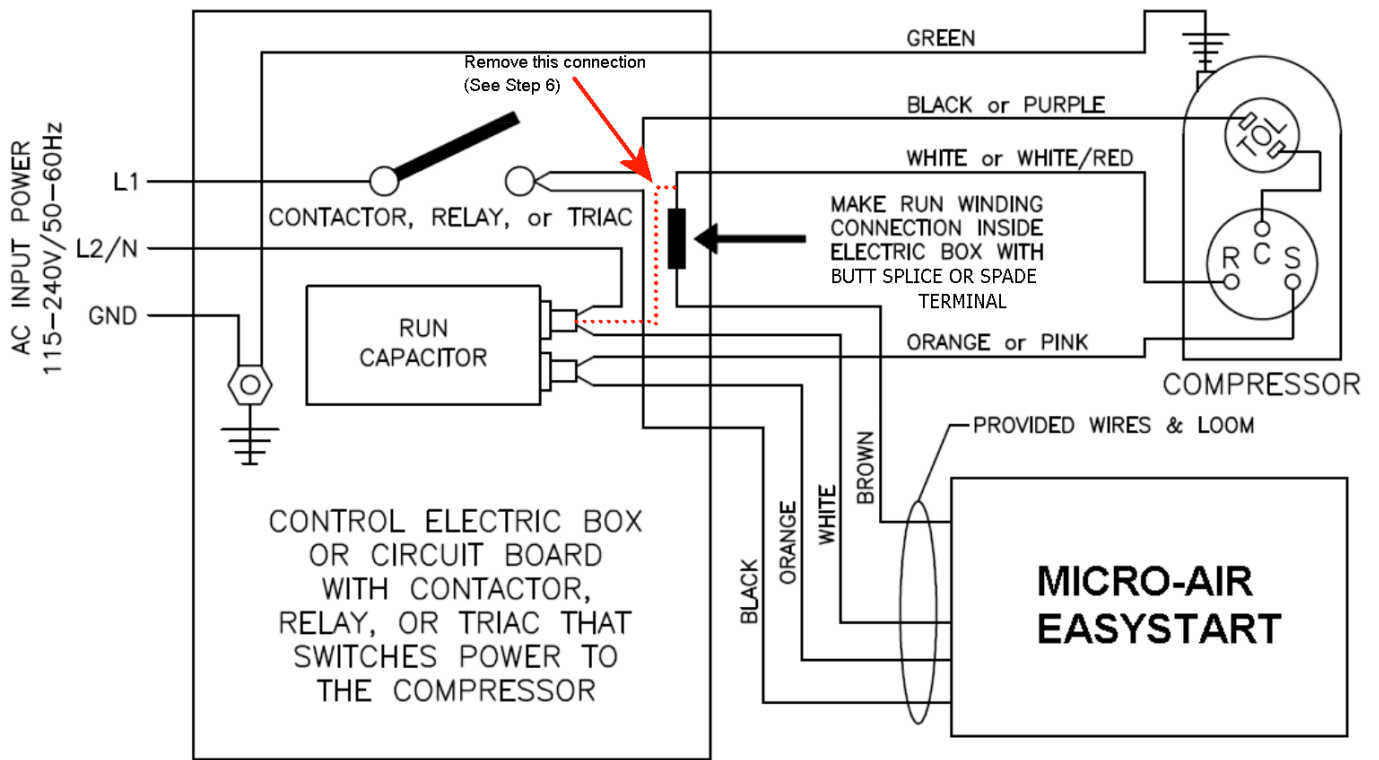

Jumper Usage:

A six pin diagnostic header is located inside the EasyStart box. Most installations will not need to access this header.

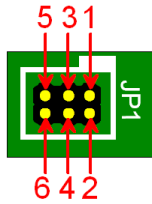

Jumpers may be placed on JP1 for certain special functions. Place jumpers only as shown below.

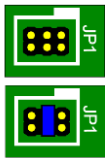

Normal: Most operation should be done without a jumper installed on JP1 or with the jumper installed across pins 3 and 4 as shown.



Default: A compressor may be operated with a factory defined start characteristic. This may not be the optimal start for the connected compressor and is generally used for factory diagnostics. No optimization is done with this setting.



Relearn: If a compressor, start capacitor, or run capacitor is replaced, place a jumper on pins 4 and 6 as shown. Cycle power on then off again and replace the jumper in the “Normal” position. Follow step 13 of the retrofit instructions to complete the relearn process.



Disable: This setting disables the microprocessor on the board so no operation can occur.

Short-Cycle Prevention Timer:

EasyStart models incorporate a timer that prevents immediate restarts. This feature was added to prevent overheating of the start capacitor and reduce faults due to un-equalized pressures in the system. Restart will take up to 5 minutes if power is removed then reapplied.

Later models include a wire jumper JP2 (see picture on right) that can be cut to eliminate this feature. System controls must be sufficient to prevent short cycling if this jumper is cut.

Warning: Starts must be limited to 1 start every 5 minutes with pressures equalized if JP2 is cut.



EasyStart Troubleshooting:

See the Micro-Air guide “EasyStart Advanced Troubleshooting Guide” available on our website for assistance in troubleshooting EasyStart installations.

Fuses:

Protection fuses are installed in the start circuit to prevent damage due to miswiring or start capacitor failure. If this fuse fails in normal operation, there is most likely a problem with the start capacitor which should be replaced along with the fuse.

364 (3 ton)

1. Revision H and earlier boards: These boards incorporate a non-replaceable fuse in the start circuit. These units must be returned to Micro-Air for repair.
2. Revision I and above boards: These boards incorporate a replaceable 15A 250V rated, slow blow, 5mm x 20mm glass fuse.

368 (6 ton)

1. Revision E and earlier boards: These boards incorporate a non-replaceable fuse in the start circuit. These units must be returned to Micro-Air for repair.
2. Revision F and above boards: These boards incorporate a replaceable 30A 250VAC rated 3AB, 3AG, ¼” x 1 ¼” (6.35mm x 31.75mm) slow blow ceramic fuse.

FAQs:

What is re-learning?

The re-learning process simply clears the EasyStart memory and returns it to as shipped condition. EasyStart should be re-learned whenever a compressor is changed or if pressures were not allowed to equalize during the learning process.

To re-learn EasyStart, remove power and open the EasyStart box. Locate the 6 pin header shown in the jumper usage section of this manual and place the shorting jumper over pins 4 and 6 as shown. Start a cycle with your thermostat with the compressor powered from AC mains and allow EasyStart to start the compressor. Remove power once the compressor starts and replace the jumper to the stored position over pins 3 and 4. Replace the cover on EasyStart and complete at least 4 additional starts. Be sure to allow time for pressures to equalize between starts, usually 3 to 5 minutes.

Be sure to remove the jumper from pins 4 and 6 and replace it to pins 3 and 4 immediately after the FIRST start and after power is removed.

I connected everything and it just won't start. What do I do now?

Micro-Air has an entire guide to help troubleshoot problems from new installations to systems that were working and develop a problem at www.microair.net. If there are any questions about wiring your unit, you can send a wiring diagram for your compressor to help@microair.net along with your question.

COPYRIGHT

© 2017 Micro-Air Corporation, All Rights Reserved

No part of this publication may be reproduced, translated, stored in a retrieval system, or transmitted in any form or by any means electronic, mechanical, photocopying, recording or otherwise without prior written consent by Micro-Air Corporation.

Every precaution has been taken in the preparation of this manual to insure its accuracy. However, Micro-Air Corporation assumes no responsibility for errors and omissions. Neither is any liability assumed nor implied for damages resulting from the use or misuse of this product and information contained herein.