



**Horizon
Reverse
Osmosis™**

Pioneer of fresh water since 1975

Seafari 170 & 350
Owner's Manual

Installation, Operation, Maintenance, & Repair

Horizon Reverse Osmosis

P.O. BOX 5463, CARSON,
CALIFORNIA 90745-5463
U.S.A.

TELEPHONE: 1-310-631-6300

FACSIMILE: 1-310-631-6395

<http://www.hrosystems.com>

sales@hrosystems.com

Horizon Reverse Osmosis Seafari 170 & 350 Revision January 2005
COPYRIGHT © 2005 Horizon Reverse Osmosis. HRO, Horizon Reverse Osmosis,
and the Horizon Reverse Osmosis Logo are Trademarks of and belong to Horizon
Reverse Osmosis with all rights reserved. "Seafari" is a Trademark of and
belongs to Horizon Reverse Osmosis with all rights reserved.

Horizon Reverse Osmosis Seafari 170 & 350 P/N B651220002 Rev March 2005

TABLE OF CONTENTS

SECTION	CONTENTS	PAGE
	Preface	iii
	System Identification Information Form	iv - v
	Warranty Registration Form	vi - vii
	Limited Warranty	viii
	Specifications	x - xii
1		Section 1
	Introduction	3
	Reverse Osmosis	3
	Piping & Interconnect Diagram Illustration	4
	Component Locations Illustrations	5
	Component Descriptions	6 - 9
	Helpful Terms	10
2		Section 2
	Packing Lists	3 - 4
	System Installation Precautions & Information	5 - 9
	System Storage Prior to Uncrating & Prior to Installation	5
	Uncrating	5
	Special Considerations	5
	Installation Cautions	5
	Reverse Osmosis Membrane Element Susceptibility to Chemical Attack	6
	Distance Between Components	6
	High Pressure Pump Preparation	6
	Tools Required for Installation	6
	Components Supplied by Installer or Owner	7 - 8
	Installation Dimensions	9
	Component Placement Illustrations	10
	System & Component Mounting	11
	Plumbing Connection Illustration	12
	Plumbing Connections	13 - 15
	Electrical Connections, Illustrations, & Wiring Diagrams	16 - 21
	Wiring Diagrams	18 - 21
	New System Commissioning	22 - 25
	New System Initial Readings Form	26
3		Section 3
	System Operation, Start Up & Shut Down	3 - 4
	Daily Operation Log System Readings Form	5 - 6
4		Section 4
	System Storage & R.O. Membrane Element Cleaning	3 - 11
	System Storage & Cleaning	3 - 11
	R.O. Membrane Element Handling & System Storage Cautions	3
	Once Through Rinse and Closed Loop Configuration Illustrations	4
	Once Through Rinse and Closed Loop Configuration Simplified Illustrations	5
	Short Term Storage	6 - 7
	Long Term Storage	7 - 8
	R.O. Membrane Element Cleaning	9 - 11

SECTION	CONTENTS	PAGE
5		Section 5
	Troubleshooting of Abnormalities	3 - 14
	Troubleshooting Cautions & Notes	3
	Troubleshooting why the System Shuts Down	4 - 5
	Pressure Readings, Pressure Gauges, Pressure Switches Abnormalities	6
	Product Water Flow & Product Water Quality Abnormalities	6 - 9
	3-Way Product Water Diversion Solenoid Valve Abnormalities	9
	High Pressure Pump Abnormalities	9 - 10
	Booster Pump Abnormalities	10 - 11
	Electrical Troubleshooting Guide	12
	Electrical & Electronic Circuit Abnormalities	13 - 14
6		Section 6
	Maintenance & Repair	3 - 18
	Warnings & Cautions	3
	Weekly Quick Check	3
	Operator Maintenance Intervals	4
	Individual Component Maintenance & Repair	5 - 18
7		Section 7
	Electrical Information	3 - 12
	Electrical Requirements & Information	3
	Motor Rotation Notes	3
	Electrical Motor Power Specifications	4
	Recommended Circuit Breaker Amperage Rating	4
	Recommended Wire Sizes	5
	Wire Size Cross Reference American Wire Gauge (AWG) vs Metric Wire Sizes	6
	Wiring Diagrams, Illustrations	7 - 11
	Control Printed Circuit Board Adjustments	12
8		Section 8
	Conversion Charts & Cross Reference Information	3 - 10
	Micron / Inch / Mesh Comparison Measurements	3
	Temperature Celsius vs Fahrenheit Conversion Chart	3
	Temperature Effect Comparison Chart	4
	Seawater Temperature & Pressure Effects Chart	5
	Water Comparison Chart Gallons / Volume / Weight	6
	PPM (Parts Per Million) Conversion Chart	7
	Pressure Comparison	8
	Metric / U.S. Customary Unit Equivalents	8
	Wire Size Cross Reference Chart AWG vs Metric	9
9		Section 9
	Exploded Parts Views	3 - 30
	Part Numbers & Descriptions, and Technical Notations	

PREFACE

Thank you for your purchase of a Horizon Reverse Osmosis Seafari 170 or 350 Reverse Osmosis Desalination System. This manual contains instructions for the installation, operation, maintenance, and repair of the Horizon Reverse Osmosis Desalination System. This information is provided to ensure extended life and safe operation of your Horizon Reverse Osmosis system.

Please read this manual thoroughly before installation or operation, and keep it for future reference. A better understanding of the system ensures optimum performance and longer service life from the system.

The instructions in this manual are intended for personnel with some general training and experience in the installation, operation, and maintenance of electro-mechanical fluid handling systems.

Horizon Reverse Osmosis' Seafari 170 & 350 Systems are designed and engineered to function as a complete working unit. Generally speaking, the performance of each component within the unit is dependent on the component prior to it and governs the performance of all components after it. Proper performance of the system is thus dependent upon proper operation of every single component within the system.

The intent of this manual is to allow the operator to become familiar with each component within the Horizon Reverse Osmosis system. By understanding the function, importance, and normal operation of each component within each subsystem of the unit, the operator can readily diagnose minor problems, which if detected early are usually easily corrected. However, if left unattended, a problem in one component eventually affects the rest of the system and leads to further repairs.

The manual is divided into chapters that address different subject matter. Each chapter should be reviewed before operating the Reverse Osmosis Desalination system.

The use of third party, non Horizon Reverse Osmosis, parts are the major documented cause of failures and problems caused to the Horizon Reverse Osmosis system. The use of third party, non Horizon Reverse Osmosis, consumables, spares, and assemblies have, can, and will damage the Horizon Reverse Osmosis system and/or specific components within the system. Do not use parts, components, consumables, or assemblies from any source other than Horizon Reverse Osmosis. Use of third party, non Horizon Reverse Osmosis, components, consumables, or assemblies will void any and all warranty of the system and/ or the effected component within the system.

Horizon Reverse Osmosis maintains inventory for immediate shipment and our Service Dealers throughout the world maintain stock of Horizon Reverse Osmosis parts. Always insist on Horizon Reverse Osmosis supplied parts for your system in order to avoid failures, eliminate problems, and maintain your Horizon Reverse Osmosis Warranty.

Horizon Reverse Osmosis

System Identification Information

INSTRUCTIONS: It is important that this form is completely filled in at the time of purchase of the Horizon Reverse Osmosis Seafari 170 or 350 Reverse Osmosis Desalinator. This information will be requested by our Service Department and Parts Order Desk whenever contacting Horizon Reverse Osmosis for technical assistance or by the Sales Department whenever ordering parts.

System Information: Seafari 170 or 350

Model Number: _____ Serial Number: _____

Operating Voltage:

Direct Current: ___ 12 VDC or ___ 24 VDC

Alternating Current: ___ 110/115 VAC or ___ 220/230 VAC

Cycles: ___ 50 Hz or ___ 60 Hz

Date Purchased: _____

Date Commissioned: _____
(First tested or operated)

Dealer Information:

Dealer's Name: _____

Address: _____

City: _____ State: _____

Country: _____ Postal Code: _____

Dealer's Invoice Number: _____

Horizon Reverse Osmosis
P.O. BOX 5463, CARSON,
CALIFORNIA 90745-5463
U.S.A.

TELEPHONE: 1-310-631-6300 • FACSIMILE: 1-310-631-6395
<http://www.hrosystems.com> • sales@hrosystems.com

Horizon Reverse Osmosis

Warranty Registration Information

INSTRUCTIONS: At the time of purchase of the Horizon Reverse Osmosis Reverse Osmosis Watermaker, please complete the warranty information listed below. After completing this form, please make a copy, and mail it to the address provided at the bottom of this form.

System Information: Seafari 170 or 350

Model Number: _____ Serial Number: _____

Operating Voltage:

Direct Current: ___ 12 VDC or ___ 24 VDC

Alternating Current: ___ 110/115 VAC or ___ 220/230 VAC

Cycles: ___ 50 Hz or ___ 60 Hz

Date Purchased: _____

Date Commissioned: _____

(First tested or operated)

Dealer Information:

Dealer's Name: _____

Address: _____

City: _____ State: _____

Country: _____ Postal Code: _____

Dealer's Invoice Number: _____

Customer Information:

Customer's Name: _____

Address: _____

City: _____ State: _____

Country: _____ Postal Code: _____

Telephone Number: _____ E-Mail Address: _____

If Vessel Installation:

Boat's Manufacture: _____

Boat's Model: _____, Length: _____ Feet or _____ Meters.

Boat's Name: _____

Mail a copy to:

Horizon Reverse Osmosis

P.O. BOX 5463, CARSON,

CALIFORNIA 90745-5463

U.S.A.

Attention: Warranty Registration

TELEPHONE: 1-310-631-6300 • FACSIMILE: 1-310-631-6395

<http://www.hrosystems.com> • sales@hrosystems.com

Horizon Reverse Osmosis Seafari 170 & 350 LIMITED WARRANTY

Horizon Reverse Osmosis warrants that the Horizon Reverse Osmosis Desalination System performs according to specifications for a period of twelve (12) months from the date of shipment. Horizon Reverse Osmosis' liability under this warranty is limited to repair or replacement of the Seafari 170 or 350 Desalination System at Horizon Reverse Osmosis' discretion. Under no circumstances is Horizon Reverse Osmosis liable for consequential damages arising out of or in any way connected with the failure of the system to perform as set forth herein. This limited warranty is in lieu of all other expressed or implied warranties, including those of merchantability and fitness for a particular purpose.

Warranty Period starts from the date of original shipment by Horizon Reverse Osmosis, or with proof of purchase from the date of sale to the original retail purchaser:

- | | |
|--|------------------|
| 1. System and accessories: | 1 (one) year |
| 2. Repairs made by Horizon Reverse Osmosis after the original warranty period has expired: | 3 (three) months |

Normal reoccurring user maintenance listed below is not covered by this or any Horizon Reverse Osmosis limited warranty:

- | | | |
|------------------------------|---------------------------------|-----------------------------|
| 1. Sea Strainer Element | 5. Pump Seal Assemblies | 9. Valve Seals and Packings |
| 2. Cartridge Filter Elements | 6. Pump Valve Assemblies | 10. Exterior Corrosion |
| 3. Fuses | 7. Pump Crankcase Oil | |
| 4. Pump Packing Assemblies | 8. Gauge Instrument Calibration | |

This or any Horizon Reverse Osmosis limited warranty does not cover installation components not supplied by Horizon Reverse Osmosis.

Improper installation resulting in the Seafari 170 or 350 system or Horizon Reverse Osmosis component failure or decline in performance is not covered by this or any Horizon Reverse Osmosis limited warranty.

The Seafari 170 or 350 Reverse Osmosis Membrane Element is guaranteed to be cleanable for a minimum of one year from date of shipment, providing cleaning periods are adhered to, and foulant is acid soluble metal hydroxides and calcium carbonates or alkaline soluble organic, inorganic substances and microbiological slimes. The Seafari 170 or 350 Membrane Element is not guaranteed against iron fouling (rust), chemical or petroleum products attack, extreme temperatures (over 120° F/under 32° F), drying out, or extreme pressures (over 1000 psig).

In the event of a defect, a malfunction, or failure specifically covered by this warranty and during the warranty period, Horizon Reverse Osmosis will repair or replace, at its option, the product or component therein which upon examination by Horizon Reverse Osmosis appears to be defective.

To obtain warranty service, the defective product or part must be returned to an authorized Horizon Reverse Osmosis Service Center or direct to Horizon Reverse Osmosis. An updated listing of Horizon Reverse Osmosis Factory Service Centers can be found on the Horizon Reverse Osmosis web site at <http://www.hrosystems.com>. The purchaser must pay any transportation or labor expenses incurred in removing and returning the product to the service center or to Horizon Reverse Osmosis.

The limited warranty does not extend to any system or system component which has been subjected to alteration, misuse, neglect, accident, improper installation, inadequate, improper repair or maintenance, or subject to use in violation of instructions furnished by Horizon Reverse Osmosis, nor does the warranty extend to components on which the serial number has been removed, defaced, or changed.

Horizon Reverse Osmosis reserves the right to make changes or improvements in its product, during subsequent production, without incurring the obligation to incorporate such changes or improvements on previously manufactured equipment.

The implied warranties, which the law imposes on the sale of this product, are expressly LIMITED in duration to the time period above. Horizon Reverse Osmosis shall not be liable for damages, consequential or otherwise, resulting from the installation, use, and/or operation of this product, or from the breach of this LIMITED WARRANTY.

CAUTION: Use of non Horizon Reverse Osmosis supplied parts and accessories, including but not limited to, maintenance parts, pre-filter elements, cleaning and storage chemical, spare parts, replacement parts, system components, installation components and/or system accessories shall void all warranty expressed or implied.

Horizon Reverse Osmosis
P.O. BOX 5463, CARSON,
CALIFORNIA 90745-5463
U.S.A.

TELEPHONE: 1-310-631-6300 • FACSIMILE: 1-310-631-6395
<http://www.hrosystems.com> • sales@hrosystems.com

SPECIFICATIONS

PERFORMANCE:

PRODUCT WATER PRODUCED PER HOUR AND PER DAY OF OPERATION:

(+/-15% at 850 psig / 56 BAR, 77°F / 25°C & 35,000 PPM TDS Feed Water Salinity)

Model Number	Production per 1 hour of operation:	Production per 24 hours of operation:
HRO Seafari 170	7 U.S. Gallons / 26.8 liters	170 U.S. Gallons / 644 liters
HRO Seafari 350	14.6 U.S. Gallons / 55.2 liters	350 U.S. Gallons / 1,325 liters

SALT REJECTION (CHLORIDE ION): Minimum 99.2 %, Average 99.4%

PRODUCT WATER TEMPERATURE: Ambient to feed water temperature

SPECIFICATIONS:

SALINITY MONITORING: Automatic computer controlled electronic monitoring. Temperature compensated with the Water Quality Indicator. The salinity monitoring components of the system give a continuous readout in micromhos per cubic centimeter, are temperature compensated and of a fail-safe design.

SALINITY RANGE OF FEED WATER:

Seawater up to 50,000 PPM TDS (NaCl) (typical seawater salinity is 35,000 PPM)

TEMPERATURE RANGE: Max. 122°F / 50°C, Min. 33°F / .5°C

SYSTEM FEED WATER:

Model Number	Power Source & Cycles (Hz)	Feed Water Flow Per Minute:
HRO Seafari 170	DC & AC (60Hz)	0.50 U.S. Gallons / 1.89 liters
HRO Seafari 350	AC (60Hz)	1.50 U.S. Gallons / 5.68 liters
HRO Seafari 170	AC (50Hz)	0.42 U.S. Gallons / 1.58 liters
HRO Seafari 350	AC (50Hz)	1.25 U.S. Gallons / 4.73 liters

REVERSE OSMOSIS MEMBRANE:

TYPE: Specifically selected High Rejection / High Yield aromatic tri-polyamides, thin film composite, spiral wound, single pass reverse osmosis membrane element.

CHLORINE TOLERANCE: 0.1 PPM.

pH RANGE: 3-11 (typical seawater pH is 8)

SYSTEM PRESSURE:

FEED WATER: Minimum 2 psi / .14 bar / .14 Kg/cm². Maximum 30 psi / 2.07 bar / 2.11 Kg/cm²

OPERATION: Seawater @ 35,000 PPM & 77° F / 25 C: Nominal 850 psi / 58.61 bar / 59.76 Kg/cm².

DIMENSIONS & WEIGHT:

MODEL	WEIGHT	LENGTH	WIDTH	HEIGHT
Seafari 170	70 lbs / 32 kg	16.75 in / 43 cm	13.25 in / 34 cm	10.00 in / 25 cm
Seafari 350	105 lbs / 47.6 kg	19.5 in / 49.53	15.5 in / 39.4 cm	13 in / 33 cm

EXTERNAL INSTALLATION WATER CONNECTIONS:

Pipe sizes to be supplied by the installer for connection of the Sea Recovery supplied components

Seafari 170

Feed Inlet:	1/2" MNPT Male National Pipe Thread U.S. Standard
Brine Discharge	1/2" MNPT Male National Pipe Thread U.S. Standard
Product	1/4" FNPT Female National Pipe Thread U.S. Standard

Seafari 350

Feed Inlet:	1/2" MNPT Male National Pipe Thread U.S. Standard
Brine Discharge	1/2" MNPT Male National Pipe Thread U.S. Standard
Product	1/4" FNPT Female National Pipe Thread U.S. Standard

ELECTRICAL MOTOR SPECIFICATIONS:

(H.P. = Horse Power; FLA = Full Load Amperes; LRA = Locked Rotor Amperes @ Start Up)

ALTERNATING CURRENT SYSTEMS:

Seafari 170:

High Pressure Pump Motor

VAC	H.P	FLA	LRA
110 - 115	1/3	6	26
220 - 230	1/3	3	13

Booster Pump Motor

VAC	H.P	FLA	LRA
110 - 115	1/8	1	20.2
220 - 230	1/8	.5	10

Seafari 350

High Pressure Pump Motor

VAC	H.P	FLA	LRA
110 - 115	1	13	52
220 - 230	1	6.5	26

Booster Pump Motor

VAC	H.P	FLA	LRA
110 - 115	1/3	6	24
220 - 230	1/3	3	12

DIRECT CURRENT SYSTEMS:

Seafari 170 only (HRO SF 350 is not available in Direct Current [DC])

High Pressure Motor Booster Pump Motor

VDC	H.P.	FLA	VDC	H.P.	FLA
12	1/3	29	12	1/8	5
24	1/3	14	24	1/8	2.5

RECOMMENDED CIRCUIT BREAKER AMPERAGE RATING:

Seafari 170

Operating Voltage	Recommended Circuit Breaker
12 VDC	40 Ampere
24 VDC	20 Ampere
115 VAC	10 Ampere
230 VAC	10 Ampere

Seafari 350

Operating Voltage	Recommended Circuit Breaker
N/A	
N/A	
115 VAC	25 - 30 Ampere
230 VAC	15 Ampere

RECOMMENDED POWER WIRE SIZE TO SYSTEM:

Seafari 170

Operating Voltage	Maximum Load	Recommended Minimum Wire Size Length of run		
		Amperage	10 Ft / 3 meter	20 Ft / 6 meter
12 VDC	34 Ampere	6 AWG / 13 mm ²	4 AWG / 19 mm ²	4 AWG / 19 mm ²
24 VDC	16.5 Ampere	8 AWG / 8 mm ²	6 AWG / 13 mm ²	6 AWG / 13 mm ²
115 VAC	7 Ampere	12 AWG / 3 mm ²	12 AWG / 3 mm ²	12 AWG / 3 mm ²
230 VAC	3.5 Ampere	12 AWG / 3 mm ²	12 AWG / 3 mm ²	12 AWG / 3 mm ²

Seafari 350

Operating Voltage	Maximum Load	Recommended Minimum Wire Size Length of run		
		Amperage	10 Ft / 3 meter	20 Ft / 6 meter
115 VAC	19 Ampere	10 AWG / 5 mm ²	10 AWG / 5 mm ²	10 AWG / 5 mm ²
230 VAC	9.5 Ampere	12 AWG / 3 mm ²	12 AWG / 3 mm ²	12 AWG / 3 mm ²

RECOMMENDED POWER WIRE SIZE TO BOOSTER PUMP:

Seafari 170

Operating Voltage	Maximum Load	Recommended Minimum Wire Size Length of run		
		Amperage	10 Ft / 3 meter	20 Ft / 6 meter
12 VDC	5 Ampere	14 AWG / 2 mm ²	14 AWG / 2 mm ²	14 AWG / 2 mm ²
24 VDC	2.5 Ampere	14 AWG / 2 mm ²	14 AWG / 2 mm ²	14 AWG / 2 mm ²
115 VAC	1 Ampere	14 AWG / 2 mm ²	14 AWG / 2 mm ²	14 AWG / 2 mm ²
230 VAC	.5 Ampere	14 AWG / 2 mm ²	14 AWG / 2 mm ²	14 AWG / 2 mm ²

Seafari 350

Operating Voltage	Maximum Load	Recommended Minimum Wire Size Length of run		
		Amperage	10 Ft / 3 meter	20 Ft / 6 meter
115 VAC	6 Ampere	14 AWG / 2 mm ²	14 AWG / 2 mm ²	12 AWG / 3 mm ²
230 VAC	3 Ampere	14 AWG / 2 mm ²	14 AWG / 2 mm ²	14 AWG / 2 mm ²

Section 1

Introduction & Component Descriptions

Horizon Reverse Osmosis' Approach to Water Desalination:

The Challenge:

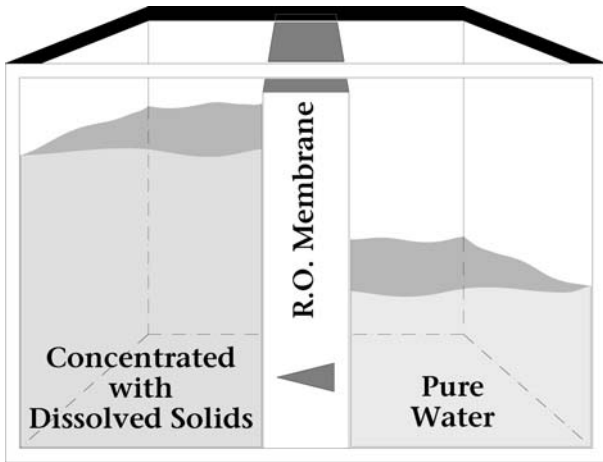

Osmosis is the diffusion of two miscible (mixable) solutions through a semi permeable membrane in such a manner as to equalize their concentration. This diffusion occurs by allowing a lesser concentration, potable water, to naturally diffuse through a semi permeable membrane into a higher concentration, sea or brackish water.

Sea water or brackish water is a high concentration solution. Potable water is a low concentration solution.

Therefore, sea water or brackish water cannot naturally diffuse through a semi permeable membrane to provide potable, drinking water.

The Solution:

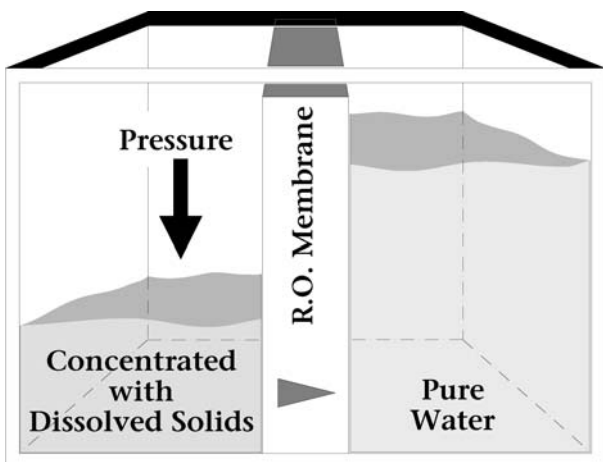

A man-made process, Reverse Osmosis, overcomes this natural phenomenon. By forcing sea or brackish water at high pressure through a semi

permeable membrane, potable water is realized. Reverse Osmosis Desalination Systems by Horizon Reverse Osmosis make possible the once impossible, potable water from undrinkable water sources.

Horizon Reverse Osmosis (HRO) was established in 1975 and became the first manufacturer of marine Reverse Osmosis watermakers for use in the boating industry.

A brilliant vision and innovative engineering allowed Horizon Reverse Osmosis to be the pioneer and forerunner in creating this most important and rewarding product the marine industry has ever seen.

HRO's watermakers have been copied by many, but matched by none. Today, Horizon Reverse Osmosis continues to make advancements in desalination technology and maintains the quality and reliability that started it all.

1. INTRODUCTION

COMPONENT DESCRIPTIONS

All components supplied by Horizon Reverse Osmosis, both standard and optional, are described in this section along with items required or desired by the installer. The location, operation, and purpose of each major component are briefly explained in this section.

The descriptions in this chapter are listed according to the ID numbers each component is given in the System Piping and Interconnect Diagram illustrated on the following page.

Throughout this manual, components are followed by a number in brackets i.e., "Sea Strainer [3]", which refers to the component's location in the illustration on the following page, the P&ID (Piping & Interconnect Diagram).

** Denotes items supplied by installer

*** Denotes optional equipment.

Seafari 170 and Seafari 350 P&ID
(Piping & Interconnect Diagram)

SEAFARI 170/350 U.S. GPD

Reverse Osmosis Desalination System

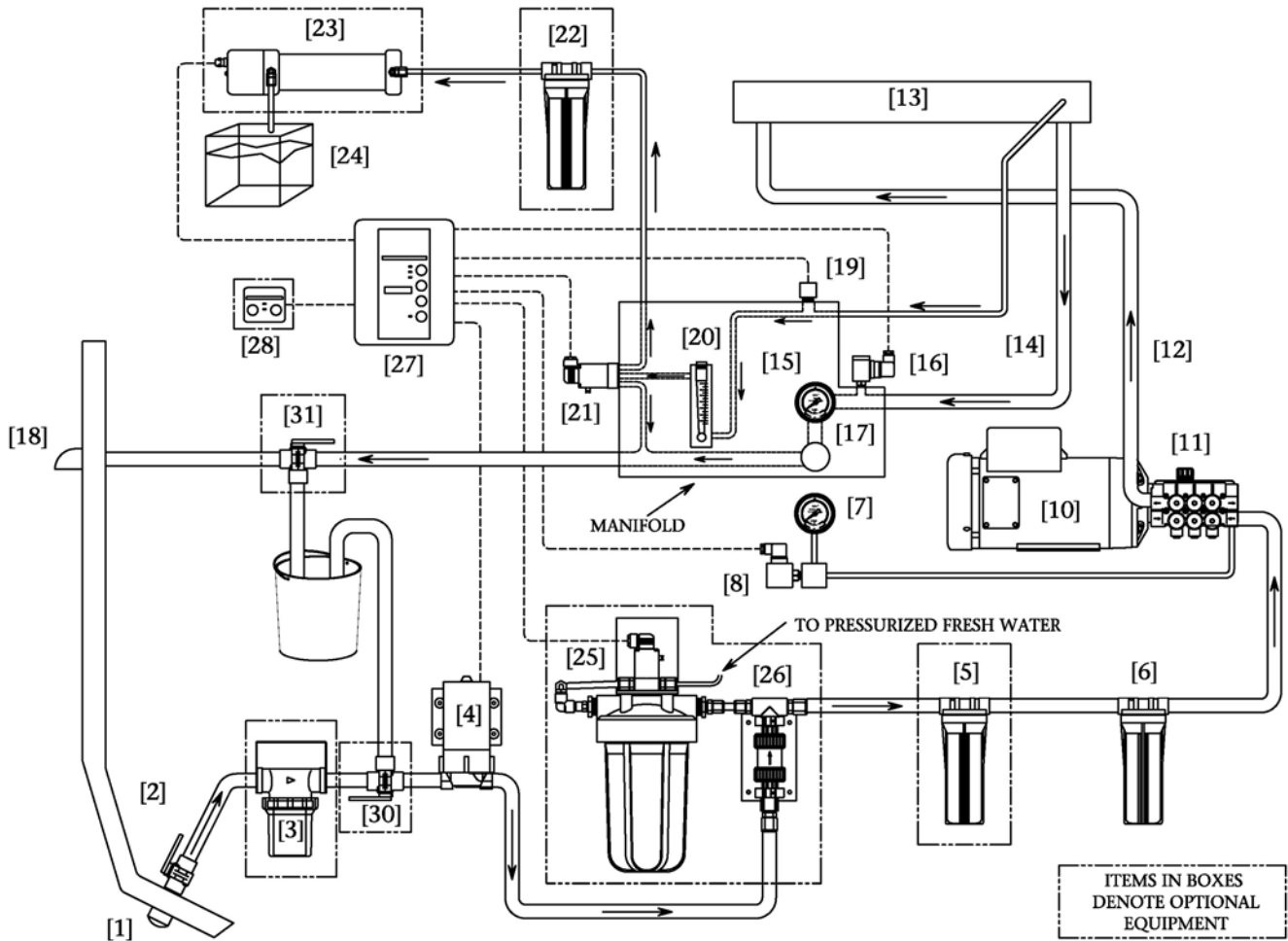

**COMPONENT
LOCATIONS:**

SEAFARI 170 COMPONENTS

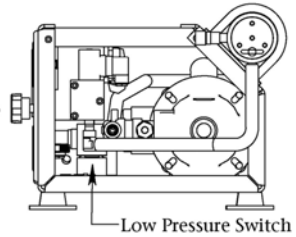
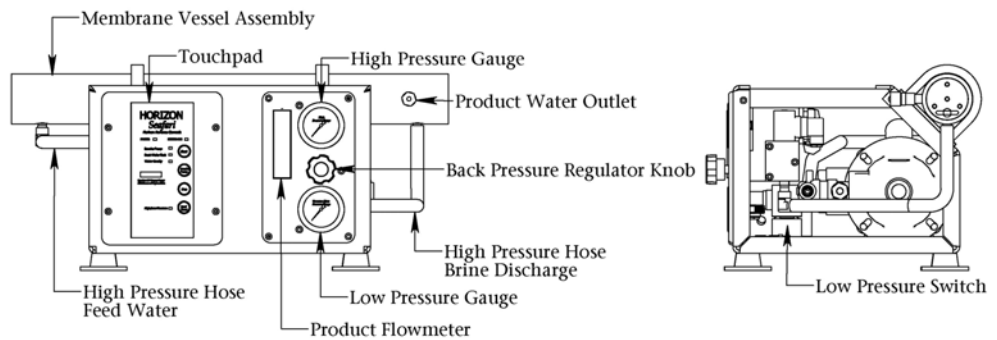
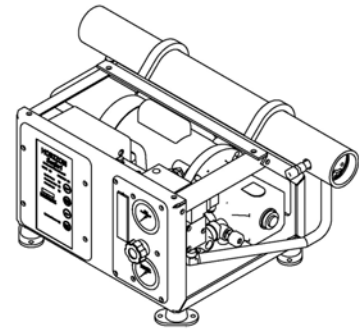
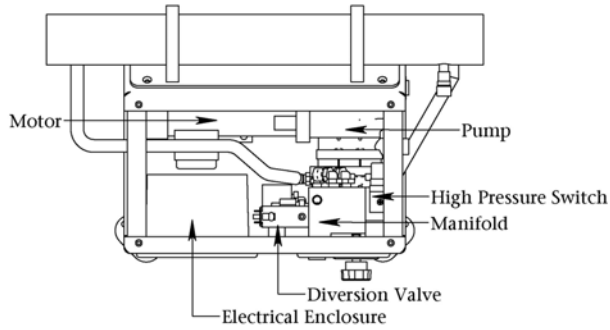

SEAFARI 350 COMPONENTS

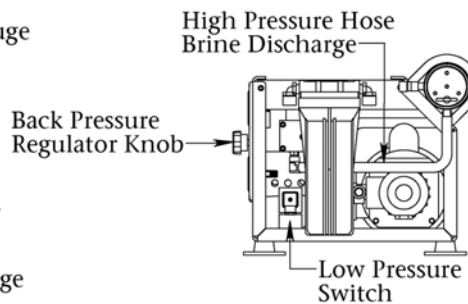
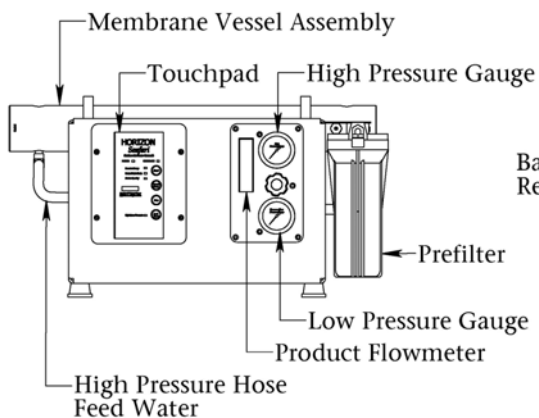
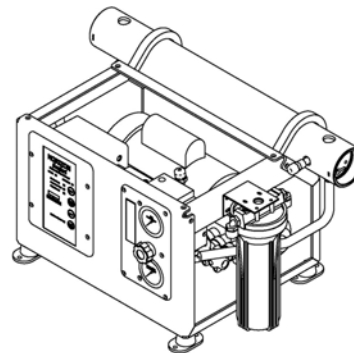
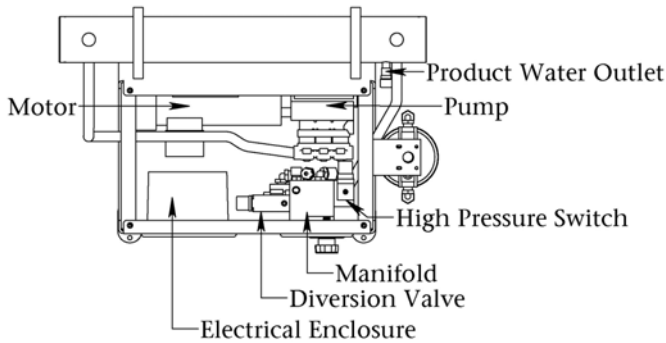

A. PREFILTRATION SUBSYSTEM:

This section of the system filters and delivers the feed water into the system. The raw feed water is filtered to remove suspended solids larger than 5 Micron size (5/1,000,000 of a meter). The pre-filtration protects the Reverse Osmosis Membrane Element from premature fouling.

1. **Inlet Thru Hull Fitting with Forward Facing Scoop** ** is the point at which the feed water enters the system. It is important that the installer utilizes a forward facing scoop so that the system receives a positive flow of water as the boat is under way.

CAUTION: A flat inlet thru-hull fitting will cause a vacuum as the boat is under way, and this will cause loss of feed water flow and cavitation of the feed water pump and high pressure pump resulting in continual system shut down due to low feed water flow and pressure. The resulting failure of the system to remain in operation is attributed to improper installation, is the liability of the installer, and is not covered by the Horizon Reverse Osmosis warranty.

CAUTION: If the thru-hull fitting is placed in a position on the underside of the hull that allows air to continually enter the thru-hull fitting, this will cause the system to continually shut down due to loss of feed water. The resulting failure of the system to remain in operation is attributed to improper installation, is the liability of the installer, and is not covered by the Horizon Reverse Osmosis warranty.

2. **Sea Cock Valve** ** is used in a ship installation for safety reasons to close the feed water line during repair, maintenance, and disuse of the system.
3. **Sea Strainer** *** has a clear bowl with nylon body filter housing or optional bronze body containing a cleanable monel fine mesh filter screen. The Sea Strainer filters out large particulate matter and suspended particles that would otherwise prematurely foul the cartridge Prefilter Element.
4. **Booster Pump** supplies a positive pressure to the Pre-filters and through to the High Pressure Pump. The Booster Pump has a

performance curve of 70 Ft Head (30 PSI) at 1.0 GPM. The resulting pressure at the High Pressure Pump depends on the final installation configuration.

5. **Plankton Filter** *** This optional filter assembly contains a cleanable ultra fine monel mesh screen. The mesh screen removes suspended solids or biological growth such as plankton. It also provides longer life to the Pre-filter Elements and in turn provides lower system maintenance costs.
6. **Pre-Filter** This filter removes suspended solids 5 Microns and larger to protect the Reverse Osmosis Membrane from fouling.

CAUTION: Do not use third party prefilter elements, use only Horizon Reverse Osmosis prefilter elements. Third party prefilter elements do not properly fit and the seams fall apart. They also allow by-pass resulting in premature fouling of the R.O. Membrane Element.

CAUTION: Do not use "string wound" or "fiber" prefilter elements. These types of elements are designed for the Photographic Film Developing Industry. When used in sea water, they will plug up rapidly in 1/10th or less the time. This will cause frequent shut downs of the system and very frequent changing which will result in very high cost of maintenance.

7. **Low Pressure Gauge** displays the Inlet Pressure to the High Pressure Pump. The gauge assists the operator in diagnosing the Sea Strainer, Booster Pump, Plankton Filter Element, and Pre Filter Element condition.
8. **Low Pressure Switch** shuts the system off automatically when a plugged filter element or other condition causes a low flow situation. This protects the High Pressure Pump, the R.O. Membrane Element, and the Booster Pump from damage.

B. PRESSURIZATION SUBSYSTEM:

Proper pressure and proper flow across the Membrane Element are two basic requirements of Reverse Osmosis. Refer to Chapter 8 for Salinity and Temperature adjustments.

9. **Future Reference**

10. **High Pressure Pump Motor** is directly coupled to the High Pressure Pump.
11. **High Pressure Pump** is a marine quality, positive displacement, ceramic plunger pump with a 316 stainless steel manifold.
12. **High Pressure Hose**, HP Pump Outlet to MVA Inlet, transfers pressurized sea water from the High Pressure Pump to the inlet of the R.O. Membrane Element.
13. **R.O. Membrane Element & Vessel.** The Membrane Element allows potable water molecules to pass through while rejecting the salt ions. Only a small percentage of the Seawater Feed becomes fresh Product Water. The remainder carries the rejected salt ions out of the R.O. Membrane Element in a concentrated brine stream.

C. BRINE DISCHARGE SUBSYSTEM:

This section of the system carries the Brine Discharge exiting from the R.O. Membrane Element.

14. **High Pressure Hose**, MVA Outlet to inlet of manifold, transfers pressurized Brine Discharge Water from the Membrane Vessel Assembly to the Control Manifold Assembly.
15. **High Pressure Gauge** displays the R.O. Membrane Vessel outlet pressure.
16. **High Pressure Switch** automatically turns the system off in case of over-pressurization during operation.
17. **Back Pressure Regulator** By turning the valve adjustment handle clockwise and counterclockwise, pressure is increased and decreased accordingly. This increases and decreases the production of the R.O. Membrane Element.
18. **Thru Hull Discharge Fitting** ** should be installed above water level for discharge of the Brine Discharge Water from the system.

D. PRODUCT WATER SUBSYSTEM:

This section of the system gives a visual indication of the clarity, quantity, and quality of the product water. Post Filtration is the final step in Product Water quality control. The Post Filtration Subsystem is designed to limit unpleasant odor and taste, as well as sterilize biological matter, which may have passed through the R.O. Membrane Element.

19. **Temperature Compensated Salinity Probe** electronically determines whether the salinity content of the Product Water is acceptable. This Salinity Probe is temperature compensated and provides an accurate measurement of Product Water quality.
20. **Flow Meter, Product Water** measures the rate of Product Water flow, in gallons and liters per hour. It measures from the R.O. Membrane Element toward the Product Water Post Filtration Components.
21. **3-Way Product Water Diversion Valve, Electric Solenoid Actuated**, the Controller energizes this valve to the "Potable" position when the system produces water which meets the low salinity requirement. If the Product Water being produced is "Un-potable", high in salinity, then no signal is sent to the valve, and it thus remains in the normal open position. The "fail safe" normal open position diverts the un-potable Product Water to discharge.
22. **Charcoal Filter** *** is designed to remove foul odors from the Product Water. Sulfurous odor (rotten eggs) is caused when decaying biological matter in the feed water section. Fresh water flushing of the system helps to minimize this.
23. **Ultra Violet Sterilizer***** destroys at least 99.9% of any virus, bacteria, and other micro-organisms which may pass through the R.O. Membrane Element. The U.V. sterilizer is recommended if the Product Water Storage Tank is not otherwise treated by means such as chlorination.
24. **Potable Water Storage Tank**** may be any container suitable for storing Potable Water, i.e. existing water storage tank.

25. **pH Neutralizer Filter***** The product water from the system will be slightly acidic. The pH Neutralizer Filter neutralizes the pH of the product water.

E. FRESH WATER FLUSH SUBSYSTEM:

Consists of supplied valves and required tank or container for the cleaning, rinsing, or storage of the R.O. System.

26. **Fresh Water Flush System***** (including charcoal filter and solenoid valve) automatically flushes the system with fresh water. This process is automatic at each shut down of the system and repeats automatically every 7 days. Fresh Water Flushing replaces the seawater in the system with less corrosive fresh water, and this also reduces the biological decay as well as biological growth that naturally occur if the feed water (sea water) is not flushed from the system with fresh water.

27. **Fresh Water Flush Check Valve Assembly ***** included with the Fresh Water Flush Optional Assembly, isolates the Fresh Water Flush system which prevents seawater from flowing in the reverse direction through the Charcoal Filter.

28. **Future Reference**

29. **Inlet Rinse Clean Valve ***** (optional) used in conjunction with the Discharge Rinse Clean Valve [31] simplifies the storage and cleaning procedures by allowing the operator to turn a valve rather than disconnect a hose. Also used for a manual fresh water flush if the Automatic Fresh Water Flush System [25] is not installed.

30. **Discharge Rinse Clean Valve ***** (optional) used in conjunction with the Inlet Rinse Clean Valve [30] simplifies the storage and cleaning procedures by allowing the operator to turn a valve rather than disconnect a hose.

F. ELECTRONIC SUBSYSTEM:

This subsystem measures water quality, controls the direction of Product Water flow, Starts and Stops the pumps, and contains the central electrical connection point of the system. It also ensures only potable Product Water passes into the Product Water Storage Tank.

31. **Salinity Controller** The controller monitors the salt content of the product water and signals the 3-Way Product Diversion Valve when Potable Water is being produced. The 3-Way Product Diversion Valve, Motors, Remote Control and U.V. Sterilizer are each governed by this controller. This enclosure houses the high-voltage components of the system. It serves as the connection point for all the electrical systems such as the motors, switches, valves, and the controller.

32. **Remote Controller ***** (optional) allows for remote monitoring and/or controlling of the system.

G. ADDITIONAL EQUIPMENT:

Soft Start*** The soft start, used only in AC (Alternating Current) Single Phase systems reduces the initial startup amperes required to start the motor and in turn allows a smaller sized KW generator to start the system.

TOUCH PAD CONTROL DESCRIPTIONS:

SWITCHES

START: This switch initiates the start cycle. The Booster Pump [4] starts first and after a short delay, the High Pressure Pump Motor [10] starts.

BOOST PUMP: This switch controls the Booster Pump [4] independent of the High Pressure Pump [11]. When pressed, the booster pump starts and runs by itself, until the "Start" switch is pressed.

STOP: This switch stops all of the system functions when pressed. Each time the system is stopped, the Fresh Water Flush system is initiated. The Fresh Water Flush cycle is aborted by pressing the Stop switch a second time.

FAULT RESET: This switch resets the High/Low Pressure fault and allows the system to start.

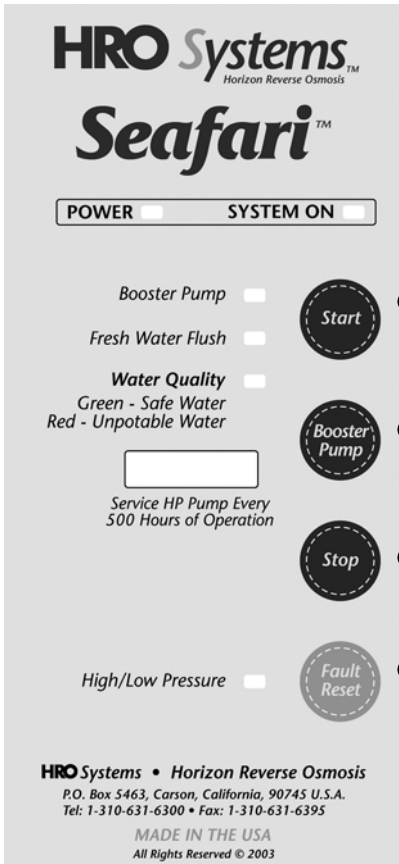

INDICATION LAMPS:

Power: This indicator is lit when power is supplied to the controller. This indicates that the main power breaker has been switched on.

System On: This lamp illuminates when the High Pressure Pump is operating.

Booster Pump: This lamp illuminates when the booster pump is operating.

Fresh Water Flush: This indicator illuminates solidly during the Fresh Water Flushing operation. When the Fresh Water Flush is in the stand-by position, in between the ten-minute flushing which repeat automatically every seven days, this lamp blinks on and off.

Product Water Quality: This lamp indicates the quality of the water being produced by the system. A red lamp illuminates when the system is producing un-potable water. A green lamp illuminates when the system is producing safe water (potable water).

High/Low Pressure: The High/Low pressure fault lamp illuminates when the system shuts down due to either a low-pressure condition, or a high-pressure condition. During operation if the Low Pressure Switch senses a low-pressure condition, this lamp blinks for twenty seconds, and then the system shuts down. If the High Pressure Switch senses a high pressure condition during operation the system will shut down immediately and the lamp will illuminate.

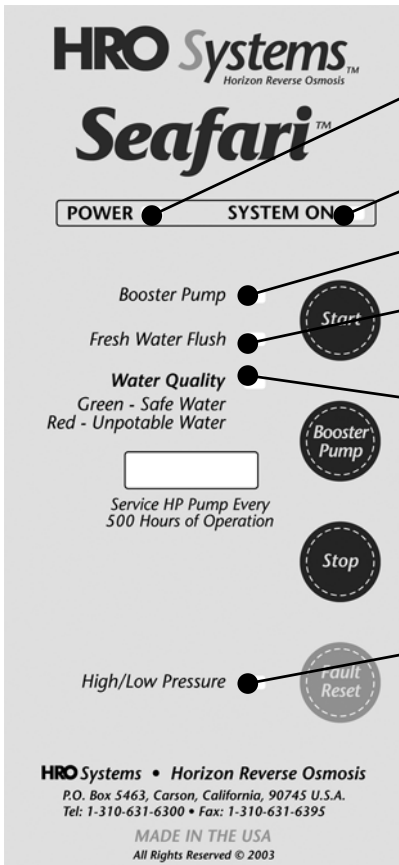

Helpful Terms to become familiar with:

- A. OSMOTIC PRESSURE:** The transfer of the water from one side of the membrane to the other will continue until the head (pressure) is great enough to prevent any net transfer of the solvent (water) to the more concentrated (feed water) solution. At equilibrium, the quantity of water passing in either direction is equal, and the pressure is then defined as the "**Osmotic Pressure**" of the solution having that particular concentration of dissolved solids.
- B. SPIRAL-WOUND MEMBRANE:** The spiral-wound membrane consists of one or more membrane envelopes each formed by enclosing a channelized product water carrying material between two large flat membrane sheets. The membrane envelope is sealed on three edges with a special adhesive and attached with the adhesive to a small diameter pipe to form a cylinder. A polypropylene screen is used to form the feed water channel between the membrane envelopes. A wrap is applied to the membrane element to maintain the cylindrical configuration. The center tube is also the permeate (product water) collecting channel. Several elements may be connected in series within a single or multiple pressure vessel(s).
- C. BOUNDARY LAYER / CONCENTRATION POLARIZATION:** When water permeates through the membrane, nearly all the salt is left behind in the brine channel. In any dynamic hydraulic system, the fluid adjacent to the wall of the vessel is moving relatively slowly. Even though the main body of the stream is turbulent, a thin film adjacent to the wall (membrane) is laminar. This thin film is called the boundary layer.
- D. COMPACTION:** Some densification of the membrane structure may take place while operating at elevated pressures, above 1000 psi. The change is known as compaction and is accompanied by a reduction in the water permeation rate.
- E. WATER TEMPERATURE EFFECT:** The product water that flow through the membrane is significantly affected by the water temperature. At any given pressure this flow increases with increasing water temperature and is reduced at lower temperatures.
- F. PRESSURE:** The operating pressure has a direct effect on product water quality and quantity. Both factors will increase as the system pressure increases (within design limits). The system must be operated at the lowest pressure required to achieve the designed product water flow rate. This parameter also affects compaction, which proceeds at a faster rate at higher pressures as well as at higher temperatures.
- G. BRINE VELOCITY:** The brine flow over the membrane surface is very important to both product water quality and quantity. At low flows, concentration polarization occurs, causing the water quality to decline. In addition to inferior product water quality, low brine flows can increase the precipitation of sparingly soluble salts which will foul the membrane surface. If this occurs, the product water flux (production) will decline.

Section 2

System Storage prior to Installation System Installation & New System Commissioning

SEAFARI 170 PACKAGING LIST



Adaptor (2)
3/8" MPT x 1/2" Barb



Elbow (1)
1/4" Tube x 1/4" MPT



Connector (1)
3/8" Tube x 1/2" MPT



Hex Screw (8)
"A" 1/4" x 1" SS



Adaptor (1)
1/2" MPT x 1/2" Barb



Hose Clamp 1/2" (7)



PVC Elbow (2)
1/2" FPT x 1/2" FPT



Washer Flat (8)
1/4" SS



1/4" Tube (30 ft)



3/8" Tube (20 ft)

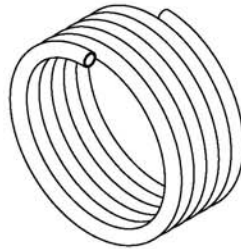

Hose Clear Braid
1/2" (20 ft)



High Pressure Pump
Crankcase Oil (1)



Seafari 170
Owner's Manual (1)

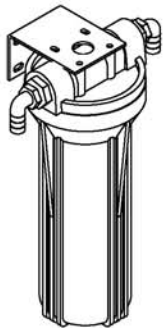

Prefilter (1)

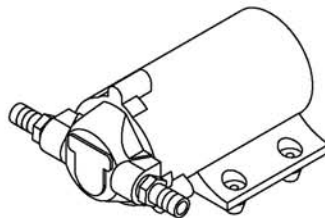

Booster Pump (1)

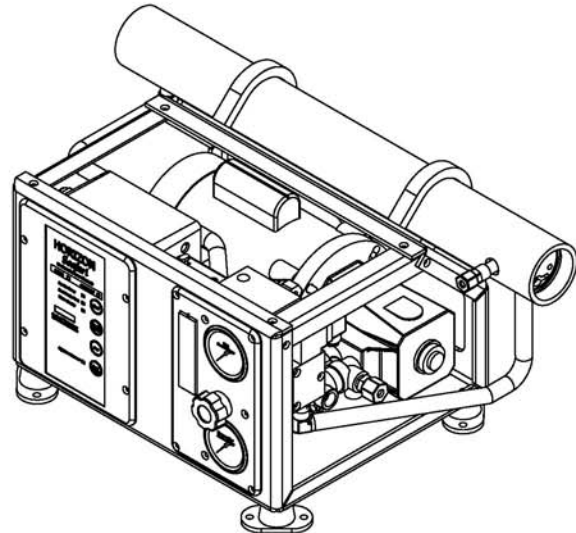

Seafari 170 (1)

SEAFARI 350 PACKAGING LIST



Adaptor (2)
3/8" MPT x 1/2" Barb



Elbow (1)
1/4" Tube x 1/4" MPT



Connector (1)
3/8" Tube x 1/2" MPT



Hex Screw (8)
"A" 1/4" x 1" SS



Adaptor (1)
1/2" MPT x 1/2" Barb



Hose Clamp 1/2" (7)



PVC Elbow (2)
1/2" FPT x 1/2" FPT



Washer Flat (8)
1/4" SS



1/4" Tube (30 ft)

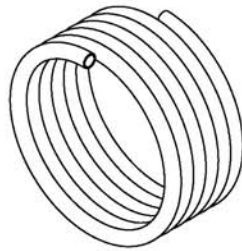

Hose Clear Braid
1/2" (20 ft)



High Pressure Pump
Crankcase Oil (1)



Seafari 350
Owner's Manual (1)



3/8" Tube (20 ft)

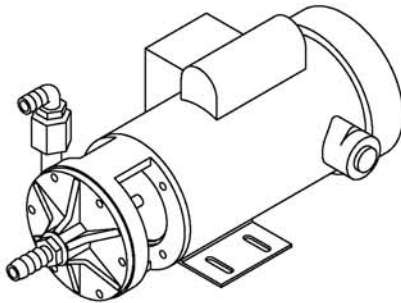

Booster Pump (1)

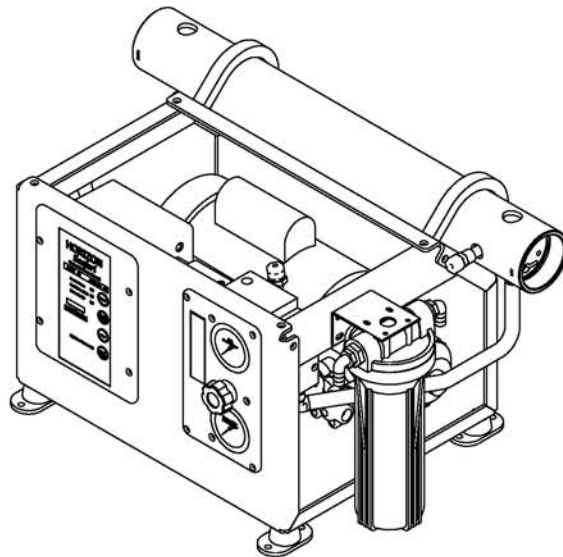

Seafari 350 (1)

SYSTEM INSTALLATION PRECAUTIONS AND INFORMATION:

A. STORAGE PRIOR TO UNCRATING:

1. Adhere to crate markings:
 - DO NOT store in direct sunlight;
 - DO NOT store above 120 degrees F / 50 degrees C;
 - DO NOT freeze;
 - DO NOT store longer than 4 months without flushing with storage chemical;
 - STORE ONLY on base with ARROWS UP.
2. Refer to Chapter 4 of this manual for further cautions of the R.O. Membrane Element.

B. UNCRATING:

1. DO NOT DISCARD ANY PACKAGING UNTIL YOU HAVE FOUND AND IDENTIFIED ALL PARTS!
2. Remove the Seafari 170 or 350 system from the shipping carton.
3. Some of the components are loose or separately packaged in the shipping container.
4. Refer to the following two pages illustrating the contents of the System.

C. SPECIAL CONSIDERATIONS:

1. Length of Connection Lines:

- All connection lines should be as short and straight as possible using minimum fittings. Increased length causes line-loss in the Feed Water line. Increased length causes excessive pressure build up in the Brine Discharge line. Increased length causes excessive pressure build up in the Product Water line.
- The connection lines must not be "kinked". Kinks in the Feed Water line cause cavitation and continual system shut down. Kinks in the Brine Discharge line cause excessive pressure build up and damage. kinks in the Product Water line cause excessive pressure build up and damage.

2. Accessibility:

- This is a simple rule: Install the system and it's supporting components in an accessible manner. The Seafari System requires regular operator maintenance such as filter element changing. As with any Electro Mechanical system utilized in the Marine environment the Seafari System will require repair from time to time. Hidden or out of reach items may become forgotten, not maintained, and cause damage to other system components.
- The Electrical Control Panel Touch Pad and the Back Pressure Regulator must be accessible for starting, stopping, and adjusting pressure of the System.

D. INSTALLATION CAUTIONS:

1. Do not over tighten PVC fittings. If threaded pipe fittings leak after installation, remove the fitting, clean the mating threads, apply 3 to 4 wraps of Teflon tape to the male threads and thread the parts back together. PVC fittings should only be hand tightened.
2. The Inlet Connection [1], Sea Strainer [3], Inlet 3-way Clean/Rinse Valve [30], and Booster Pump [4] should be below water level. This will aid the Booster Pump in priming.
2. Always allow hoses and tubes to enter and exit straight from the connection for a minimum of one inch prior to a bend
6. Avoid skin and eye contact with the membrane packaging solution. In case of skin contact, rinse the skin thoroughly with water. In case of eye contact, flush repeatedly with water and notify a physician immediately. Membrane Element are stored in sodium bisulfite.
7. NEVER mount any liquid holding component of the system above an electrical or electronic circuit or device. Extensive damage to the electrical or electronic device or circuit will result if water spills from the system during maintenance and or component failure.

E. REVERSE OSMOSIS MEMBRANE ELEMENT SUSCEPTIBILITY TO CHEMICAL ATTACK:

CAUTION: Do Not expose the Horizon Reverse Osmosis System to intake Feed Water containing:

Hydrogen peroxide	chloramines	chloramines-T	N-chloroisocyanurates
Chlorine dioxide	hypochlorite	chlorine	iodine
Bromine	Bromide	phenolic disinfectants	petroleum products

Any chemical, not approved in writing by HRO Systems.

USE OF NON-AUTHORIZED OR MISUSE OF AUTHORIZED CHEMICALS VOIDS SYSTEM

WARRANTY. Do not connect any water line to the System that may contain any of the above listed chemicals. Example: Do not connect the inlet of the System to the ship's potable water system if the system contains chlorinated or brominated water. These chemicals destroy the copolymer components within the system. These oxidants and others also damage the R.O. Membrane Element. The Horizon Reverse Osmosis Optional Fresh Water Flush Accessory removes chlorine and bromine from the ship's potable water system.

F. DISTANCE BETWEEN COMPONENTS:

1. 20 feet (6 meters) of 1/2" (12.7 mm) ID inlet suction hose is supplied for connecting:

Outlet of	to	Inlet of
Sea Cock Valve [2]		Sea Strainer [3]
Sea Strainer [3]		Inlet 3-Way Clean/Rinse Valve [30]
Inlet 3-way Clean/Rinse Valve [30]		Rinse/Clean bucket or container
Inlet 3-way Clean/Rinse Valve [30]		Booster Pump [4]
Booster Pump [4]		Fresh Water Flush Check Valve [26]
Fresh Water Flush Check Valve [26]		Plankton Filter [5]
Plankton Filter [5]		Prefilter [6]
Prefilter [6]		High Pressure Pump [11]

2. 20 feet (6 meters) of 3/8" O.D. (9.5 mm) nylon tube is supplied for connecting:

Outlet of	to	Inlet of
System Brine Discharge		Discharge 3-way Clean/Rinse Valve [31]
Discharge 3-way Clean/Rinse Valve [31]		Rinse/Clean Bucket or container
Discharge 3-way Clean/Rinse Valve [31]		Thru Hull Discharge fitting [18]

3. 30 feet (9.14 meters) of 1/4" (6.35 mm) OD nylon tubing is supplied for connecting:

Outlet of	to	Inlet of
Potable Product Water from System		Charcoal Filter [22]
Charcoal Filter [22]		U.V. Sterilizer [23]
U.V. Sterilizer [23]		pH Neutralizing Filter
pH Neutralizing Filter		Boats Potable Water Storage Tank [24]

G. HIGH PRESSURE PUMP PREPARATION:

1. Remove the shipping tape from the High Pressure Pump Oil Fill Cap to expose the Oil Fill Cap air breather hole.
2. Ensure that the pump oil level is even with or higher than the center of the pump sight glass. Damage to the High Pressure Pump will occur if the wrong oil is used in its crankcase. Use only HRO Systems supplied pump oil.

H. TOOLS REQUIRED FOR INSTALLATION: Not all installations are typical, therefore, it is recommended to have a full set of Mechanic's and Electrician's tools available. No special system tools are required for installation. A separate TDS Meter, available from Horizon Reverse Osmosis will assist in confirming system product water quality. A volt/ohm meter (VOM) is required for system installation and commissioning to ensure proper electrical power and connection.

I. COMPONENTS SUPPLIED BY INSTALLER OR OWNER:

CAUTION: All fittings, valving, and piping installed prior to, within, and after the Horizon Reverse Osmosis system must not contain iron. They must be non-ferrous material (not containing iron). Iron fittings or piping will cause rust fouling and failure of the R.O. Membrane Element. The resulting failure of the R.O. Membrane Element is attributed to improper installation, is the liability of the installer, and is not covered by the Horizon Reverse Osmosis warranty.

1. Water Connections to be supplied by the installer:

Seafari 170:

Feed Inlet: 1/2" MNPT Male National Pipe Thread U.S. Standard
Brine Discharge 1/2" MNPT Male National Pipe Thread U.S. Standard
Product 1/4" FNPT Female National Pipe Thread U.S. Standard

Seafari 350:

Feed Inlet: 1/2" MNPT Male National Pipe Thread U.S. Standard
Brine Discharge 1/2" MNPT Male National Pipe Thread U.S. Standard
Product 1/4" FNPT Female National Pipe Thread U.S. Standard

2. **Inlet Thru Hull Fitting with Forward Facing Scoop** [1]. The inlet Thru Hull Fitting must be dedicated to only the Horizon Reverse Osmosis system. It is important that the installer utilizes a forward facing scoop so that the system receives a positive flow of water as the boat is under way. The fitting must be installed on the boats hull in a position that provides continual feed water flow without air to the system.

CAUTION: A flush inlet thru-hull fitting will cause a vacuum as the boat is under way, and this will cause loss of feed water flow and cavitation of the Booster Pump and High Pressure Pump resulting in continual system shut down due to low feed water flow and low pressure. The resulting failure of the system to remain in operation is attributed to improper installation, is the liability of the installer, and is not covered by the Horizon Reverse Osmosis warranty.

CAUTION: The Seafari system must receive an uninterrupted supply of feed water without air. If the thru-hull fitting is placed in a position on the underside of the hull that allows air to continually enter the thru-hull fitting, this will cause the system to continually shut down due to loss of feed water. The resulting failure of the system to remain in operation is attributed to improper installation, is the liability of the installer, and is not covered by the Horizon Reverse Osmosis warranty.

CAUTION: The Seafari system must not be tied into another existing auxiliary water line already supplying another accessory on the boat. Using one Thru Hull fitting for other equipment will cause the Seafari system to draw air or cavitate leading to continual system shut down. The resulting failure of the system to remain in operation is attributed to improper installation, is the liability of the installer, and is not covered by the Horizon Reverse Osmosis warranty.

CAUTION: If the Seafari System is connected to a Sea Chest or Stand Up Pipe, do not plumb the Seafari system feed line to the "top" of the Sea Chest or Stand Up Pipe. If plumbed into the top of these feed water arrangements, the Seafari system will experience continual shut down due to air inducement into the system. Plumb the Seafari to the "bottom" of such feed water arrangements to ensure a continual air free supply of feed water to the system.

3. **Inlet Sea Cock Valve** [2] Quarter turn ball valve min. 1/2" size, with a 1/2" MNPT connection for mating to the supplied 1/2" FNPT fitting.

4. **Brine Discharge Thru Hull Fitting** [18] minimum 1/2" size with a 1/2" MNPT connection for mating to the supplied 1/2" FNPT fitting. The Brine Discharge Thru Hull Fitting should be installed above water level. No valves should be installed in this line. If a closed valve was the cause of damage and failed the system, it will not be covered by the Horizon Reverse Osmosis Warranty.
5. **Connection to the boat's Potable Water Storage Tank** [24] requires a 1/4" FNPT connection for mating to the supplied 1/4" MNPT fitting. In order to avoid problems such as reverse flow (osmosis) from the tank to the system and chlorination attack of the R.O. Membrane Element, the fitting must terminate above the maximum water level. No valves should be installed in this line. If a closed valve was the cause of damage and failed the system, it will not be covered by the Horizon Reverse Osmosis Warranty.

6. **Recommended Circuit Breaker Amperage Rating:**

Seafari 170:		Seafari 350:	
Operating Voltage	Recommended Circuit Breaker	Operating Voltage	Recommended Circuit Breaker
12 VDC	40 Ampere	N/A	
24 VDC	20 Ampere	N/A	
115 VAC	10 Ampere	115 VAC	25 - 30 Ampere
230 VAC	10 Ampere	230 VAC	15 Ampere

7. **Properly sized Power Cables:** **CAUTION:** DO NOT USE ROMEX TYPE SOLID CORE WIRE. SOLID CORE WIRE CAN EASILY BREAK AND WILL NOT FIT OR SEAL INTO THE SUPPLIED STRAIN RELIEFS. USE ROUND JACKETED STRANDED WIRE PREFERABLY WITH AN OUTER JACKET DESIGNATION OF SJO OR SIMILAR COMPATIBLE WITH MARINE USE AND AN OILY ENVIRONMENT. FOR DC OPERATION FINE STRAND WIRE, SIMILAR TO BATTERY CABLE, IS PREFERRED FOR MINIMAL RESISTANCE, MINIMAL VOLTAGE DROP, AND EASE OF ROUTING (EASILY FORMED AND BENT).

Recommended Power Wire Size to SYSTEM:

Seafari 170:		Recommended Minimum Wire Size		
Operating Voltage	Maximum Load Amperage	Length of run		
		10 Ft / 3 meter	20 Ft / 6 meter	30 Ft / 9 meter
12 VDC	34 Ampere	6 AWG / 13 mm ²	4 AWG / 19 mm ²	4 AWG / 19 mm ²
24 VDC	16.5 Ampere	8 AWG / 8 mm ²	6 AWG / 13 mm ²	6 AWG / 13 mm ²
115 VAC	7 Ampere	12 AWG / 3 mm ²	12 AWG / 3 mm ²	12 AWG / 3 mm ²
230 VAC	3.5 Ampere	12 AWG / 3 mm ²	12 AWG / 3 mm ²	12 AWG / 3 mm ²
Seafari 350:				
115 VAC	19 Ampere	10 AWG / 5 mm ²	10 AWG / 5 mm ²	10 AWG / 5 mm ²
230 VAC	9.5 Ampere	12 AWG / 3 mm ²	12 AWG / 3 mm ²	12 AWG / 3 mm ²

Recommended Power Wire Size to BOOSTER PUMP:

Seafari 170:		Recommended Minimum Wire Size		
Operating Voltage	Maximum Load Amperage	Length of run		
		10 Ft / 3 meter	20 Ft / 6 meter	30 Ft / 9 meter
12 VDC	5 Ampere	14 AWG / 2 mm ²	14 AWG / 2 mm ²	14 AWG / 2 mm ²
24 VDC	2.5 Ampere	14 AWG / 2 mm ²	14 AWG / 2 mm ²	14 AWG / 2 mm ²
115 VAC	1 Ampere	14 AWG / 2 mm ²	14 AWG / 2 mm ²	14 AWG / 2 mm ²
230 VAC	.5 Ampere	14 AWG / 2 mm ²	14 AWG / 2 mm ²	14 AWG / 2 mm ²
Seafari 350:				
115 VAC	6 Ampere	14 AWG / 2 mm ²	14 AWG / 2 mm ²	12 AWG / 3 mm ²
230 VAC	3 Ampere	14 AWG / 2 mm ²	14 AWG / 2 mm ²	14 AWG / 2 mm ²

8. **An electrical power source** Refer to Electrical Specifications at the beginning of this booklet.

DIMENSIONS

SEAFARI 170 DIMENSIONS

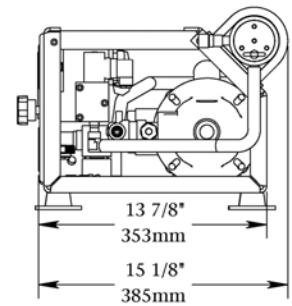
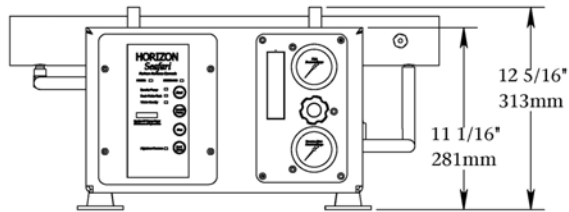
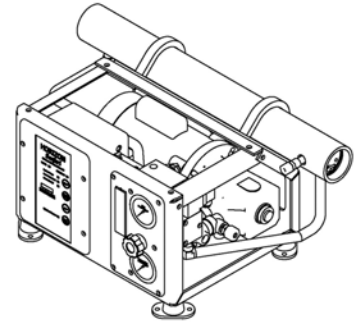
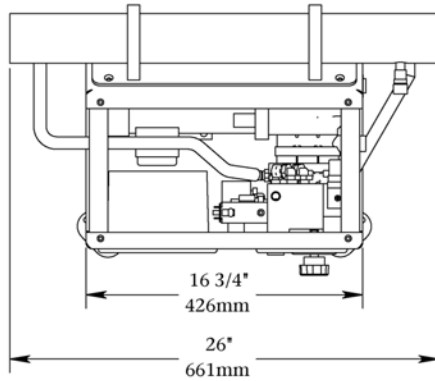

SEAFARI 350 DIMENSIONS

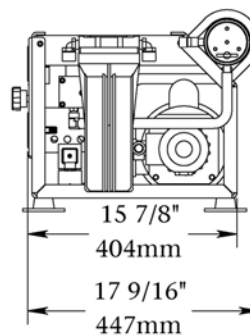
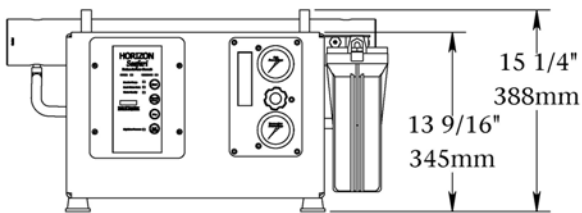
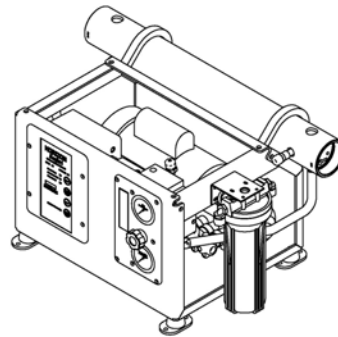
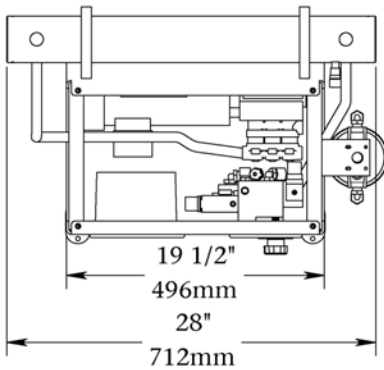

1. MAJOR COMPONENT MOUNTING

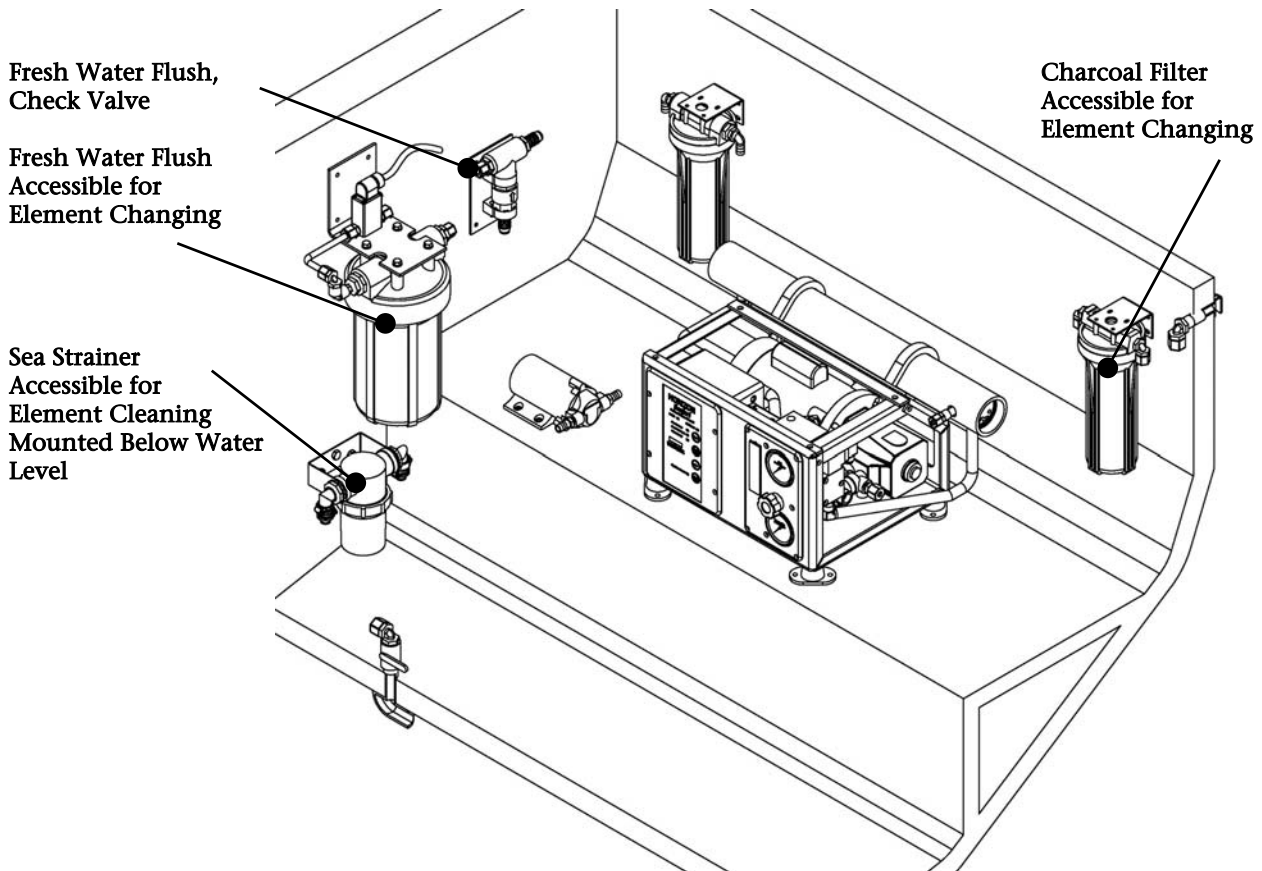
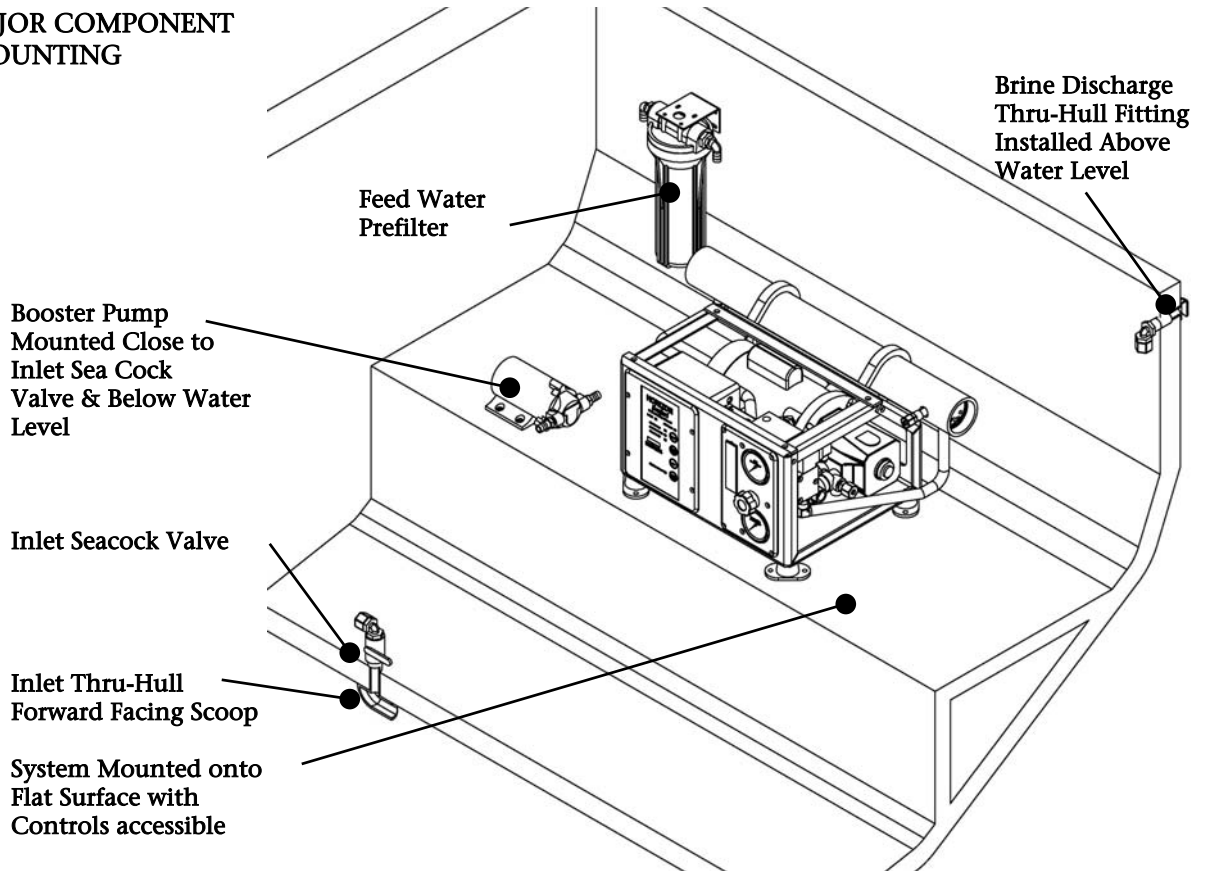

SYSTEM & COMPONENT MOUNTING: The following steps discuss the installation of the Seafari 170 or 350. The prior illustrations show the system installed in the port-aft section of a boat as an example. It is understood that this location or configuration may not always be possible, and there are a variety of locations the system may be mounted. The components in the illustrations are spaced far apart only to allow illustration of the hose and tube connections between components.

The mounting surfaces must be flat in order to avoid warping of brackets and frames. Use appropriate shims on uneven surfaces to ensure that mounting of the system components does not cause bending or warping.

- a. The System is mounted to a flat surface using the 4 supplied 1/4" x 1" Type "A" screws.
- b. The Optional Sea Strainer is mounted below water level between the Inlet Sea Cock Valve and Booster Pump. Allow at least 4 inches (10 cm) of clearance below the bowl to access the mesh screen for cleaning or replacement.
- c. The Optional Fresh Water Flush Filter Canister is mounted to a Vertical Bulkhead. Allow at least 4 inches (10 cm) of clearance below the bowl for element replacement.
- d. Mount the Fresh Water Flush Check Valve Assembly **vertically** in close proximity to the Booster Pump, Fresh Water Flush Filter Canister, and the Pre-Filter.
- e. The Booster Pump is mounted to a flat surface using the 4 supplied #10 x 1 1/4" long Type "A" screws. The Booster Pump is mounted below water level to assist priming, and in an accessible location to allow access for maintenance. Mount Booster Pump close to the Inlet Thru Hull/ Sea Cock Valve and the Sea Strainer (if purchased). If the booster pump is mounted vertically, mount the motor up and pump head down. Do not mount the pump head above the motor else motor damage will occur if the pump or its fittings should develop a leak.
- f. The Optional Plankton Filter is mounted inline between the Booster Pump and the Pre Filter. Allow at least 4 inches (10 cm) of clearance below the bowl for element replacement.
- g. The Pre-filter is mounted to a bulkhead using the 4 supplied #10 Type "A" 1" long screws. Allow minimum 4 inches (10 cm) below the bowl for filter element removal. Feed water may spill during filter element replacing. Therefore, Do Not mount the prefilter above any electrical or electronic component
- h. The Optional Charcoal Filter is mounted to a vertical bulkhead using the 4 supplied #10 x 1" long Type "A" screws.
- i. Mount the UV Sterilizer (not shown) to a bulkhead directly after the Charcoal Filter. The UV should be mounted vertically to displace air from the sterilizing chamber, with the electrical fitting on the top. The UV should be plumbed with the inlet on the bottom and the outlet on top. Horizontal mounting is acceptable with outlet port on top (pointed up) to displace air.
- j. Attach the supplied Sea Cock Inlet Fitting Assembly, 1/2 " FNPT elbow with attached 1/2" hose barb to the boats Sea Cock 1/4 turn ball valve.
- k. Attach the supplied Brine Discharge Outlet Fitting Assembly, 1/2 " FNPT elbow with attached 3/8" Tube Fitting to the boats Over board Discharge Fitting.
- l. Attach the supplied Product Water Tank Connector 1/4" MNPT x 1/4" Tube Fitting to the 1/4" FNPT tap at the Potable Water Tank.

2. PLUMBING CONNECTIONS

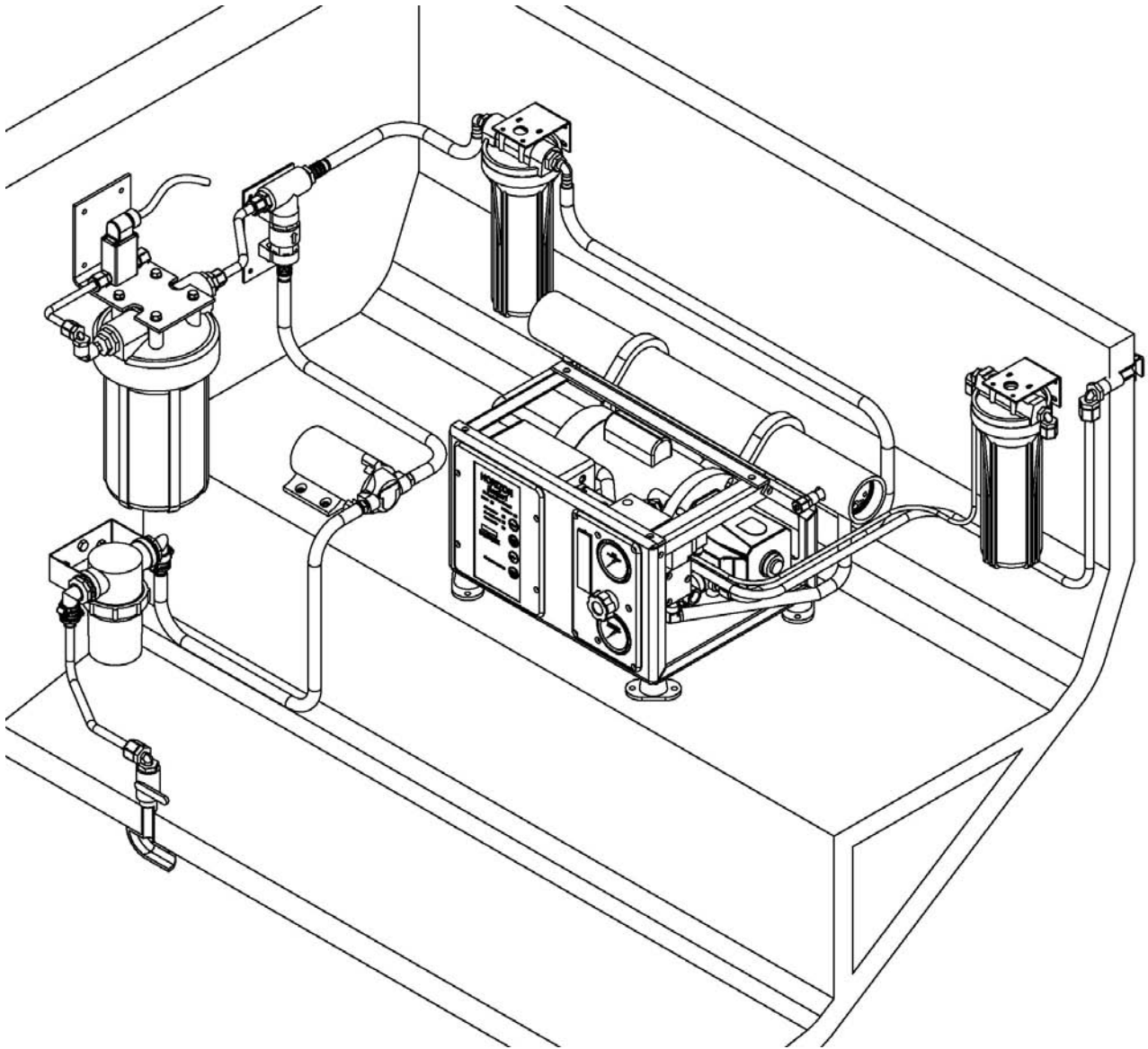

CAUTION: Always allow slack in water lines. Allow the line to enter or leave from the fitting in a straight manner for several inches to ensure proper connection, to relieve stress to the fitting and tube or hose, and to allow ease of detachment and reattachment during maintenance or repair. If water lines are pulled tight causing them to bend at the fitting they will leak, allow air to enter, fail prematurely, and/or break the fitting that they are attached to.

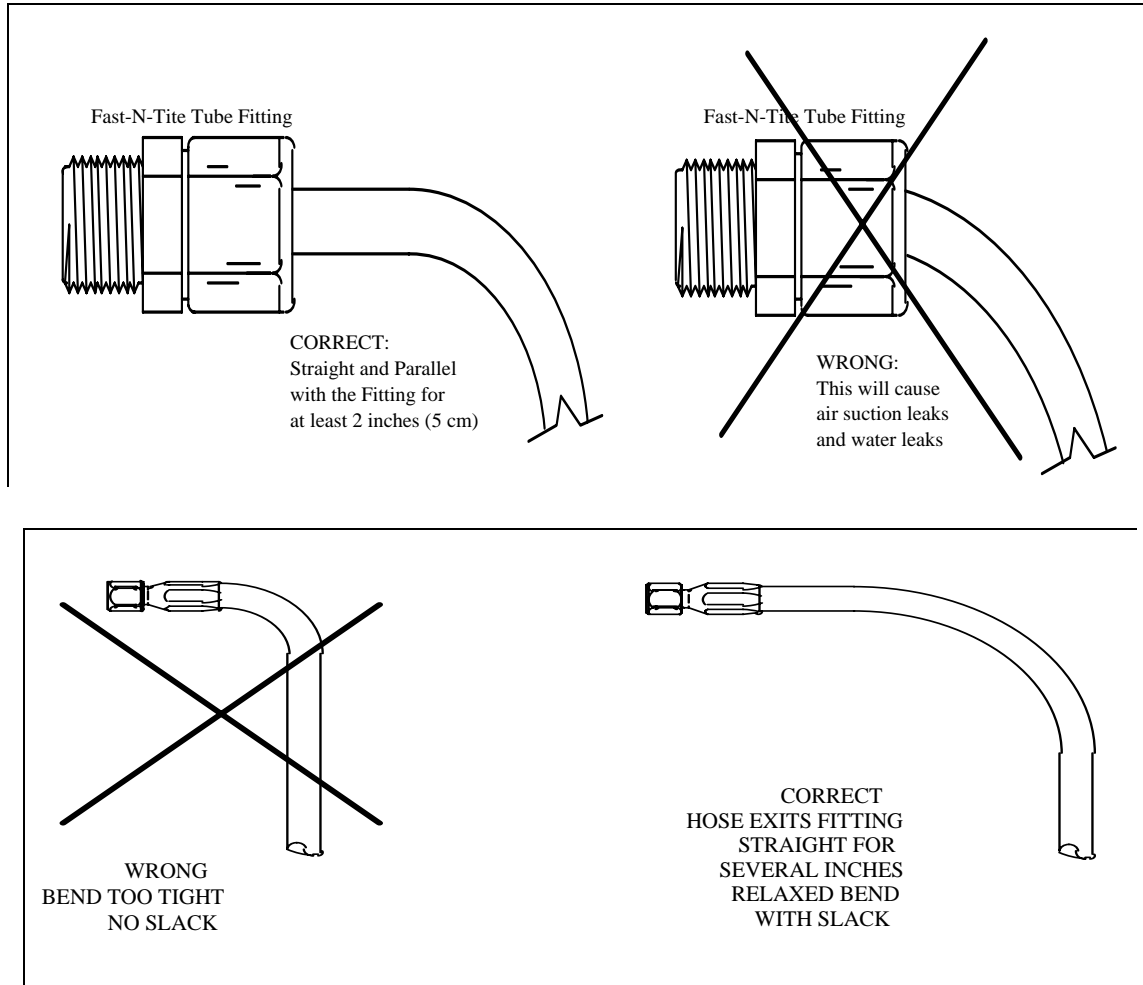

a. Connect all inlet feed lines with the supplied 20 feet (6 meters) of 1/2" (12.7 mm) I.D. Inlet Suction Hose:

Outlet of
Sea Cock Valve [2]
Sea Strainer [3]
Inlet 3-way Clean/Rinse Valve [30]
Inlet 3-way Clean/Rinse Valve [30]
Booster Pump [4]
Fresh Water Flush Check Valve [26]
Plankton Filter [5]
Prefilter [6]

to Inlet of
Sea Strainer [3]
Inlet 3-Way Clean/Rinse Valve [30]
Rinse/Clean bucket or container
Booster Pump [4]
Fresh Water Flush Check Valve [26]
Plankton Filter [5]
Prefilter [6]
High Pressure Pump [11]

High Pressure Pump

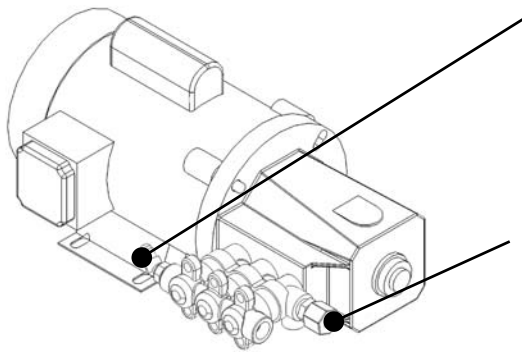

High Pressure Outlet to Inlet of Membrane/Vessel Assembly Pre-Connected

Feed Water Inlet from Prefilter Outlet Requires Attachment

TUBE FITTING CONNECTIONS ASSEMBLY

- a. Cut tube end square and clean.
- b. Loosen nut on fitting three turns.
- c. Insert tube into fitting until it bottoms. Loosen nut completely and remove tube with attached parts from body. Check to ensure that the O-Ring is seated onto the tube under the spacer (and not pinched into the body). Insert tube with attached parts into the body and tighten nut finger tight.

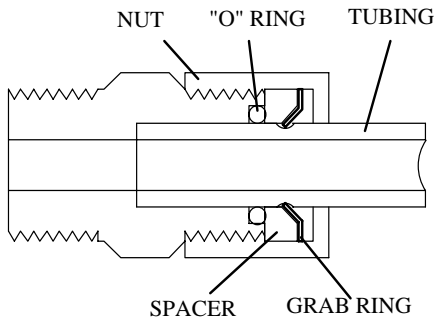

- b. Connect Brine Discharge line with the supplied 20 feet (6 meters) of 3/8" (9.5 mm) O.D. Brine Discharge Tubing (refer to illustrations on the following page):

<p>Outlet of System Brine Discharge Discharge 3-way Clean/Rinse Valve [31] Discharge 3-way Clean/Rinse Valve [31]</p>	<p>to</p>	<p>Inlet of Discharge 3-way Clean/Rinse Valve [31] Rinse/Clean Bucket or container Thru Hull Discharge fitting [18]</p>
--	-----------	--

- c. Connect Product Water line with the supplied 30 feet (9.14 meters) of 1/4" (6.35 mm) O.D. nylon tubing (refer to illustrations on the following page):

<p>Outlet of Potable Product Water from System Charcoal Filter [22] U.V. Sterilizer [23] pH Neutralizing Filter</p>	<p>to</p>	<p>Inlet of Charcoal Filter [22] U.V. Sterilizer [23] pH Neutralizing Filter Boats Potable Water Storage Tank [24]</p>
--	------------------	---

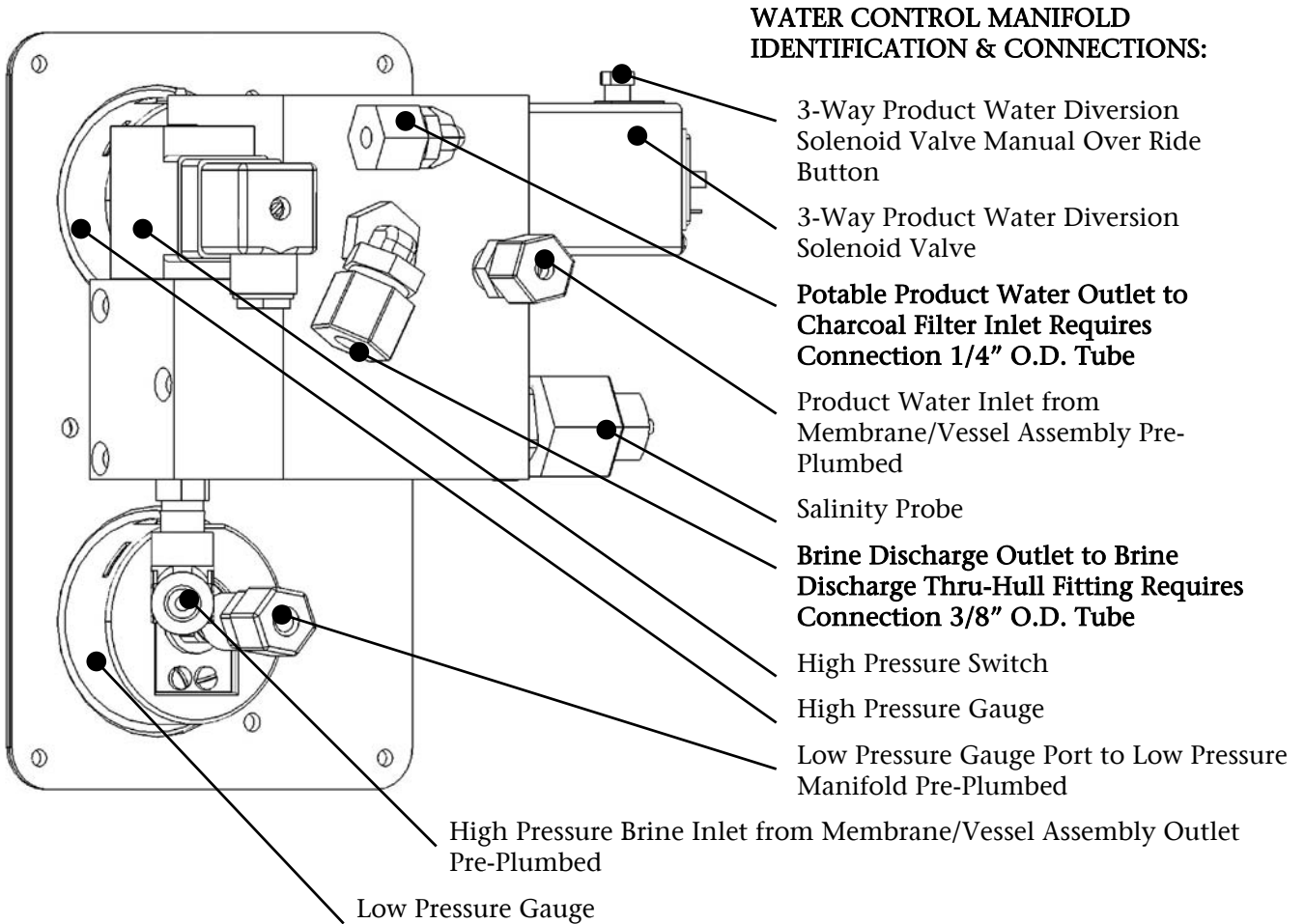

3. ELECTRICAL CONNECTIONS

CAUTION: Always allow slack in electrical cables. Allow the cable to enter or leave from the strain relief in a straight manner for several inches to ensure proper connection, to relieve stress to the cable and fitting, and to allow ease of detachment and reattachment for maintenance or replacement. If electrical cables are pulled tight causing them to bend at the strain relief, they will pull out of the strain relief causing a dangerous electrical shock condition, the wire may break, and the strain relief will lose its water-tight integrity.

- a. Remove the front cover from the system controller to access the Main Terminal Strip and Printed Circuit Board.

REFER TO APPROPRIATE WIRING DIAGRAM ON THE FOLLOWING PAGES OF THIS SECTION.

- b. Main Power: Insert main power cable through strain, see insert below. Connect main power cable leads to the system, see appropriate wiring diagram on following pages of this section.
- c. Booster Pump: Insert Booster Pump power cable through strain relief, see insert below. Connect Booster Pump power cable leads to the system, see appropriate wiring diagram on following pages of this section.
- d. Fresh Water Flush Solenoid Valve: Remove strain relief hold plug from the side of the control box, see insert below, and attach the Fresh Water Flush Solenoid Valve strain relief supplied with the Fresh Water Flush Accessory. Insert power cable through the strain relief. Connect Fresh Water Flush Solenoid Valve power cable leads to the System, see appropriate wiring diagram on following pages of this section.
- e. U.V. Sterilizer: Remove strain relief hold plug from the side of the control box, see insert below, and attach the U.V. Sterilizer strain relief supplied with the U.V. Sterilizer Accessory. Insert power cable through strain relief. Connect U.V. Sterilizer power cable leads to the system, see appropriate wiring diagram on following pages of this section.
- f. Remote Control: Remove strain relief hold plug from the side of the control box, see insert below, and attach the Remote Control strain relief supplied with the Remote Control Accessory. Insert power cable through strain. Connect Remote Control power cable leads to the system, see appropriate wiring diagram on following pages of this section.

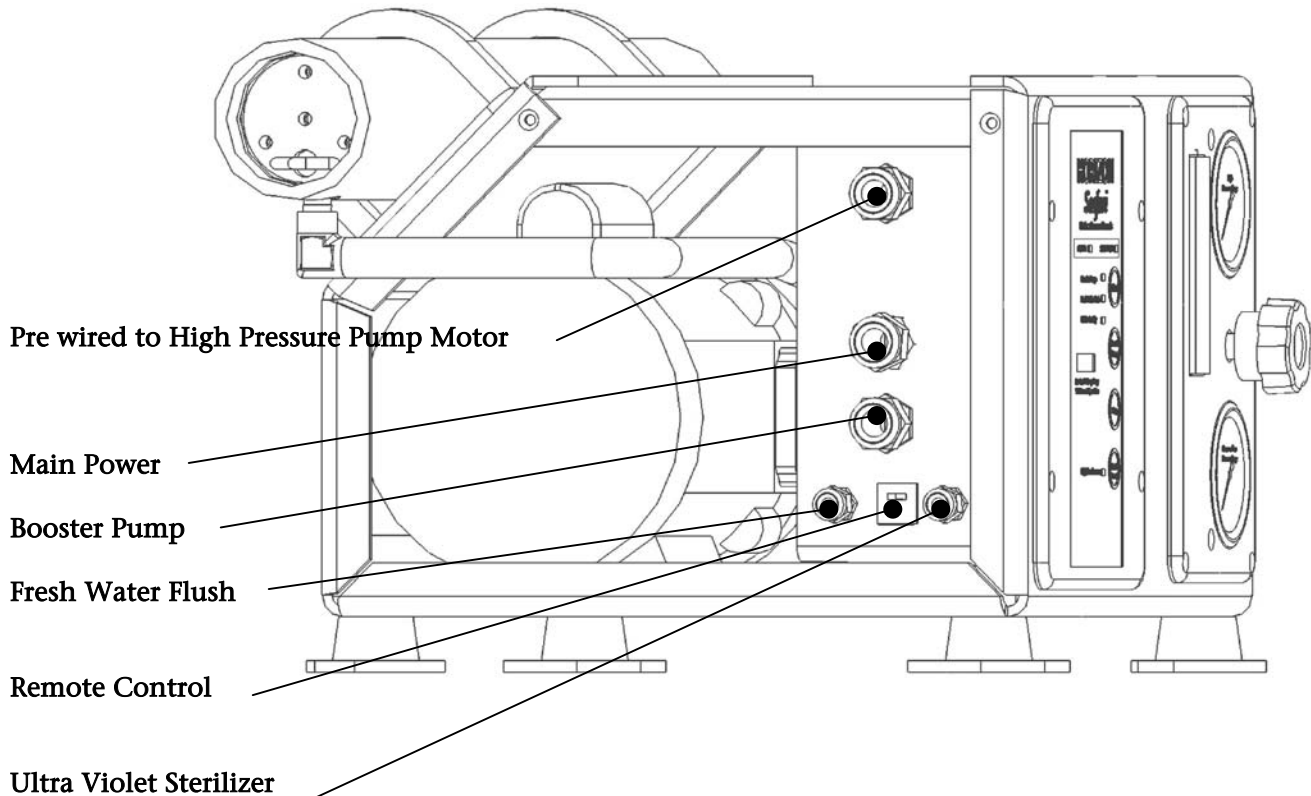

Electrical Line Drawings & Electrical Connections

Seafari 170 12 VDC

Seafari 170 24 VDC

Seafari 170 115/230 VAC

Seafari 350 115 VAC

SEAFARI 170 ELECTRICAL DIAGRAM 12 VDC Controller

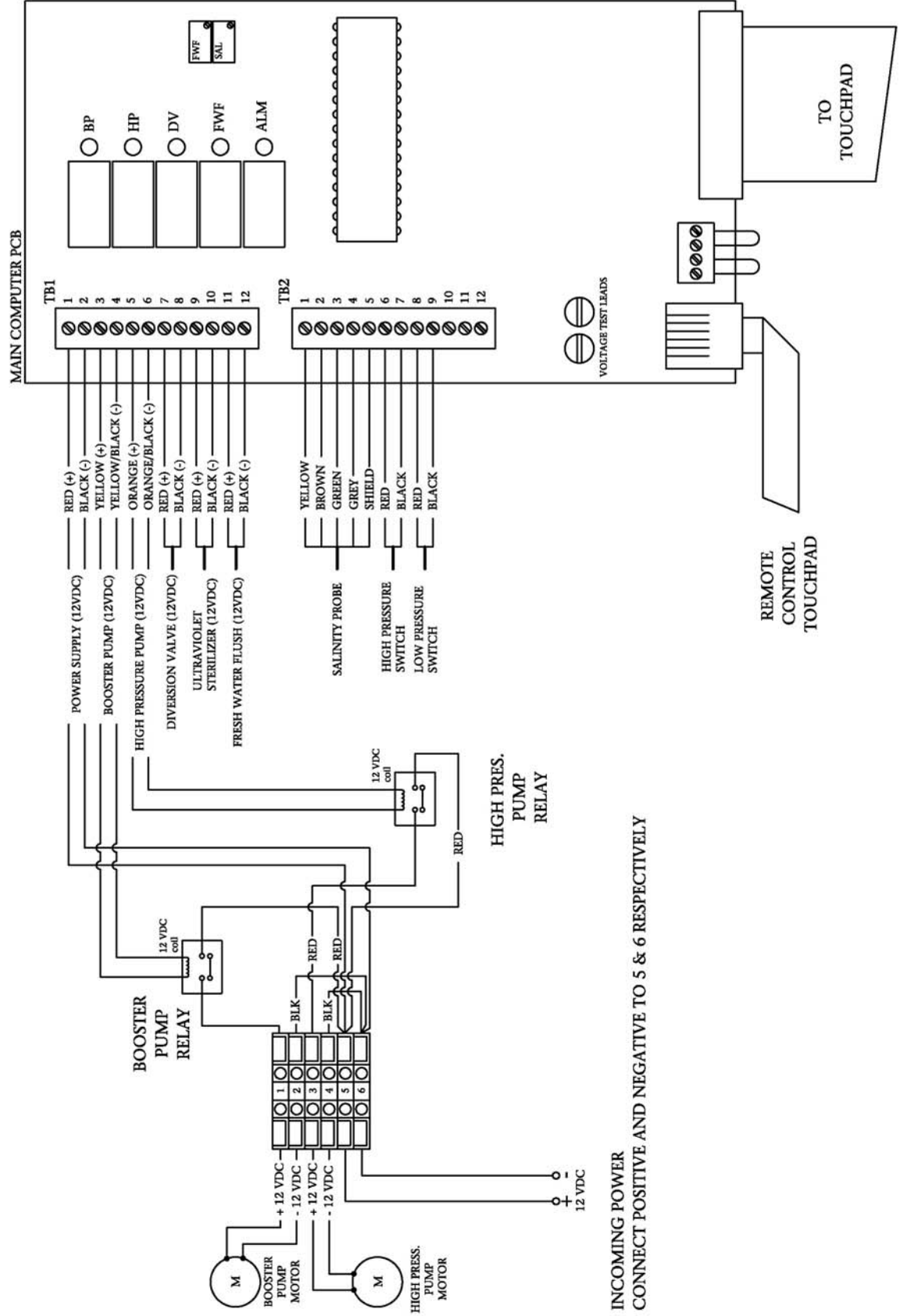

INCOMING POWER
CONNECT POSITIVE AND NEGATIVE TO 5 & 6 RESPECTIVELY

SEAFARI 170 ELECTRICAL DIAGRAM 24 VDC Controller

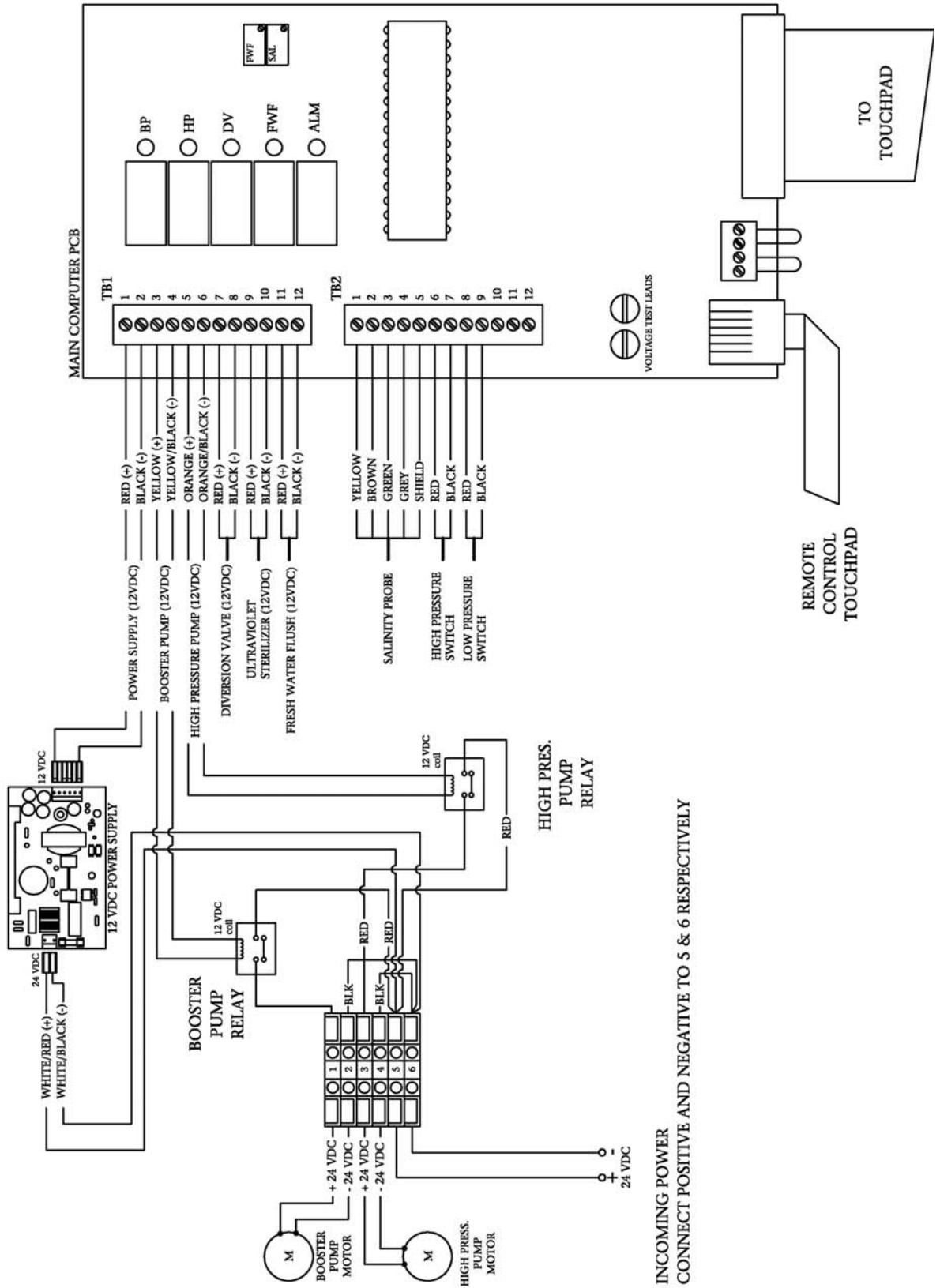

SEAFARI 170 ELECTRICAL DIAGRAM

110/220 VAC Single Phase Controller

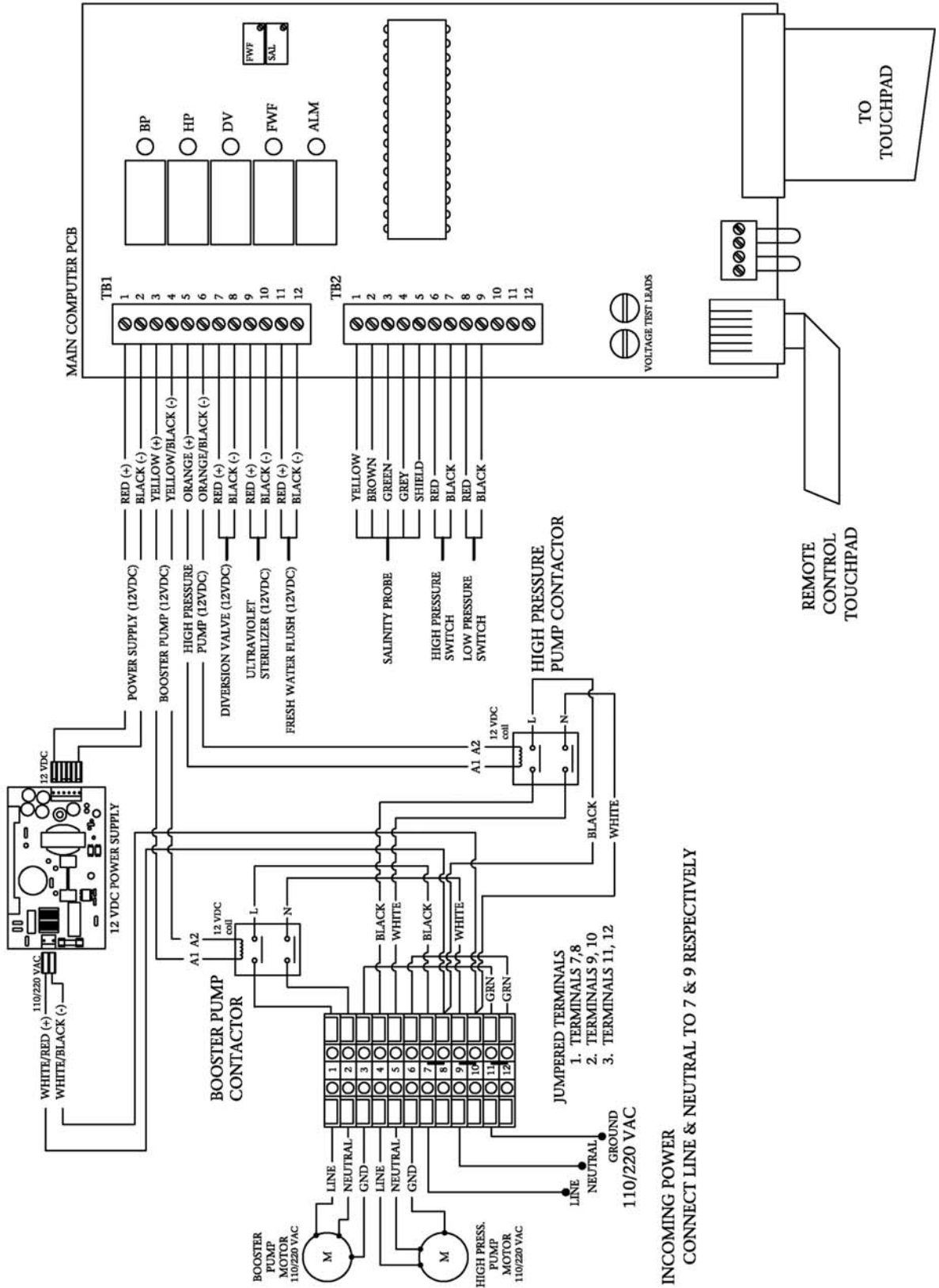

SEAFARI 350 ELECTRICAL DIAGRAM 110/220 VAC Single Phase Controller

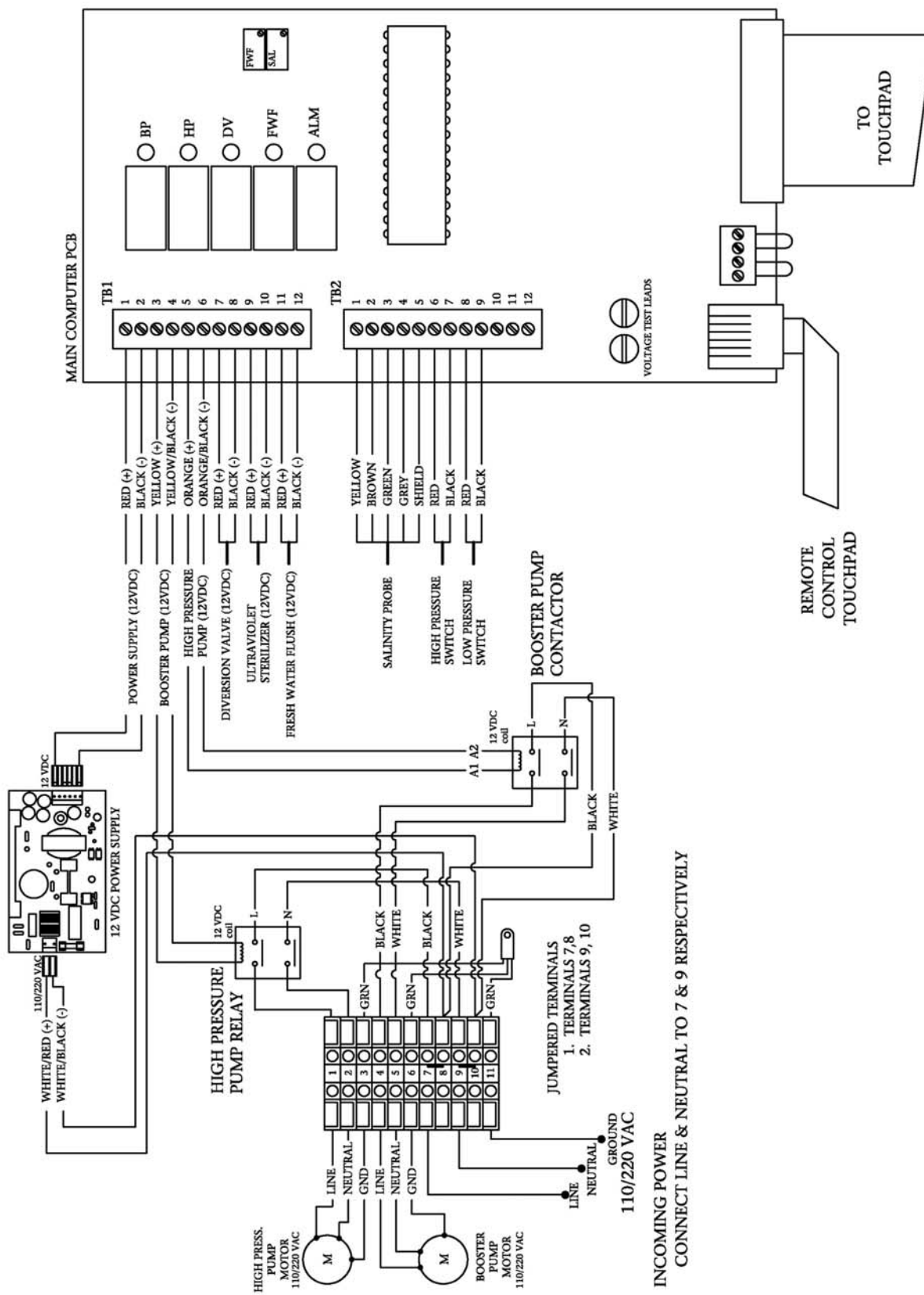

4. SYSTEM COMMISSIONING:

INITIAL START-UP PROCEDURE OF A NEW Seafari 170 or 350:

Throughout this Manual, Numbers in [brackets] refer to the I.D. numbers illustrated below.

The Commissioning instructions must be carried out for initial start-up of a NEW system. For every day use starting procedures, refer to Chapter 3, Operation.

Failure to follow these instructions exactly leads to system failure and causes damage to the components. Read this section and other appropriate sections of the manual in order to gain familiarity with the requirements of the system and functions of each component.

SEAFARI 170/350 U.S. GPD
Reverse Osmosis Desalination System

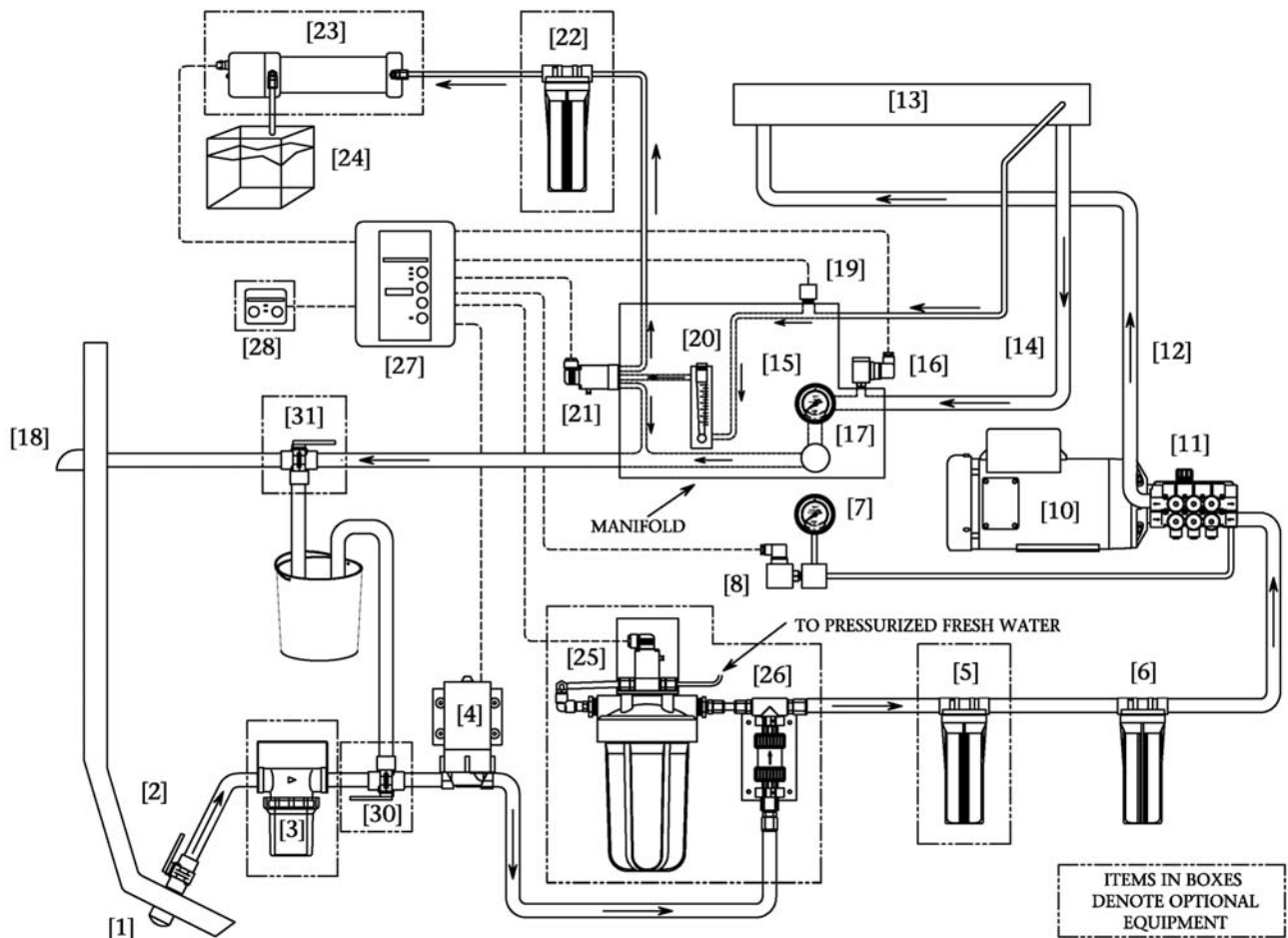

START-UP PROCEDURE OF A NEW Seafari 170 or 350:

1. Ensure that the installation has been properly performed as per the instructions in this section.
2. Ensure that the shipping tape from the High Pressure Pump Oil Fill Cap has been removed to expose the Oil Fill Cap air breather hole.
3. Ensure that the pump oil level is even with or higher than the center of the pump sight glass. Damage to the High Pressure Pump will occur if the wrong oil is used in its crankcase or if the oil level is not at minimum required level. Use only HRO Systems supplied pump oil. The supplied Pump Oil is special hydraulic oil, which contains anti rust and wear inhibitors essential to the high-pressure pump crankcase section.
4. Ensure that the tube shipping plug has been removed from the Potable Water outlet port of the Water Control Manifold and that 1/4" product water tube is connected, refer to page 15 of this section.
5. Reverse Osmosis Element: **CAUTION:** Some systems are shipped WITHOUT the Reverse Osmosis Membrane Element. This is to accommodate, for example, Boat Builders that install the system well in advance of commissioning the boat and the Seafari 170 or 350.

If the Reverse Osmosis Membrane Element has been installed, there will be a Reverse Osmosis Membrane Element Serial Number tag, illustrated below, attached to the High Pressure Vessel. Find this Serial Number tag to ensure that the R.O. Membrane Element has been installed.

If the R.O. Membrane Element Serial Number tag is missing or does not contain a serial number and date, then immediately contact the company that sold the system to you, the installer, or Horizon Reverse Osmosis.

DO NOT attempt to operate the system without a Reverse Osmosis Membrane Element installed in the system otherwise extensive damage will result.



6. Check each tube connection to the System to ensure that the installer has properly connected and properly routed each tube. Improper routing and any blockage in any line causes damage to the system. *Do not rely on the installer's word; check it yourself.*
7. Make sure that the Electrical Power Source, boat's circuit breaker to the system, is switched "OFF".
8. Open the front panel of the Main Power Enclosure and check all electrical and electronic connections for proper wiring and attachment. Refer to the wiring diagrams in this section.

9. Close the Main Power Enclosure front panel.
10. Ensure that the manual By-Pass lever on the Diversion Valve [21] is positioned outward (away from the coil body).
11. Open any auxiliary Valve within the incoming Feed Line; Outgoing Brine Discharge Line; and Outgoing Product Water Line.

CAUTION: If any auxiliary valve is installed in these lines, it will damage the Seafari if left closed during starting and/or operation of the system.

12. Open the Back Pressure Regulator Valve [17] FULLY OPEN by turning counter clockwise.

CAUTION: The Back Pressure Regulator Valve [17] must be fully open when starting the Seafari 170 and 350. If this valve is left closed, it will cause damage to the system.

13. Switch the Electrical Power Source, boat's circuit breaker to the system "ON".

14. **HIGH PRESSURE ELECTRIC MOTOR ROTATIONAL CHECK:** Ask an assistant to view the fan section of the Booster Pump Motor [4] and High Pressure Pump Motor.[10] while you "Jog" the system.

Press the "Booster Pump" switch, and then immediately press the "Stop" switch. Ensure that the Booster Pump Electric Motor is turned in the proper rotation as indicated by an arrow on the front of the pump. If the motor is turned in the wrong direction, refer to the wiring diagrams in this section to correct. To change rotation in DC systems, reverse polarity to the respective electric motor.

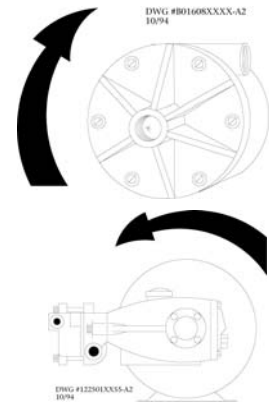

Press the "Start" switch, and then immediately press the "Stop" switch. Ensure that the High Pressure Pump Electric Motor is turned in the proper rotation. If the motor is turned in the wrong direction, refer to the wiring diagrams in this section to correct. To change rotation in DC systems, reverse polarity to the respective electric motor.

15. To start the system press the "Start" switch or press the "Booster Pump" switch and then the "Start" switch. If the system automatically shuts off, after several seconds of operation, this may be due to a system fault. Look at the Touch Pad to confirm whether a fault has occurred. If the "High/Low Pressure" Fault Lamp is illuminated ensure that the System Feed Line is primed and that there is no air in the Feed Water Line. Press the Fault Reset button on the Touch Pad and restart the system. Initial New System Commissioning will require priming of the Feed Water through the prefiltration section in order to build sufficient feed water pressure to maintain operation.

HIGH/LOW PRESSURE FAULT LAMP EXPLANATION:

- a. Low Pressure Fault: When the inlet pressure to the high-pressure pump falls below 6 psi, the "High/Low Pressure" lamp blinks. If the condition is not corrected, the system shuts down after 20 seconds.

The Low Pressure switch monitors this condition caused by a closed Inlet Sea Cock Valve, air in the feed line, or restriction in the inlet line.

When commissioning a NEW system, the feed line may require priming.

A new system may also have a blockage, manufacturing debris, clogging the inlet thru-hull fitting. This is the most common problem experienced in commissioning a new system. Do not assume that the Thru-Hull fitting port is clear. Caulking, rags, and debris are commonly found blocking the Thru-Hull.

- b. High Pressure Fault Lamp: The High Pressure Switch stops the system if pressure exceeds 950 psi.

Ensure that the Back Pressure Regulator [17] is fully open, counter clockwise.

Ensure that there are no kinks and no valves installed on the Brine Discharge Line. If there is a valve on the Brine Discharge Line, ensure that it is fully "open".

16. After 5 minutes of running un-pressurized, slowly adjust the Back Pressure Regulator Valve [17] by turning clockwise to increase the pressure to the proper setting (example: Approximately 850 psi for 35,000 ppm seawater @ 77° F).

WHILE ADJUSTING THE BACK PRESSURE REGULATOR TO OPERATING PRESSURE, OBSERVE THE PRODUCT WATER FLOW METER.

DO NOT EXCEED 7 GALLONS PER HOUR ON THE SEAFARI 170 SYSTEM

DO NOT EXCEED 14.5 GALLONS PER HOUR ON THE SEAFARI 350 SYSTEM.

DO NOT EXCEED 900 PSI ON HIGH PRESSURE GAUGE.

17. If any abnormality develops, stop the system and correct the problem.
18. Although the system is producing "product water", the "product water" may not be "potable" for up to 30 minutes. The salinity of the Product Water diminishes gradually, until it reaches the factory setting at which time it is directed to the "potable" (good water) position and into the Post Filtration components onward to the Ship's Storage Tank [24]. At the same time, the Water Quality LED on the Touch Pad changes from red to green.
19. Check for:
 - a. A constant feed water flow.
 - b. A consistent system pressure.
 - c. Leaks in the system.
 - d. Abnormal noises or other occurrences.

**Horizon Reverse Osmosis Seafari 170 and 350
NEW SYSTEM INITIAL READINGS**

At the time of commissioning the NEW system, record the following information after one hour of continuous proper operation of the system. Retain this form in the Owner's Manual for future reference and troubleshooting.

Retain the form in this Owners Manual for the owner and operator's future reference. This information is valuable to the servicing technicians in providing technical support to the owner and future operators of the Seafari 170 or 350. Provide this information to service technicians when requesting technical assistance.

Serial Number: _____ Model Number: Seafari 170 _____; or Seafari 350 _____

Name of Operator: _____ Date: _____

Installer Information:

Company _____

Street Address _____

City, State _____

Country, postal code _____

Telephone number _____

Name of Installer _____

System Power: _____ Volts AC, _____ Hz or _____ Volts DC

Feed Water Temperature: _____ ° Fahrenheit or _____ ° Celsius

Hour Meter Reading: _____ Hours

PRESSURE GAUGE READINGS:

Low Pressure Gauge Reading: _____ psi High Pressure Gauge reading: _____ psi

WATER FLOW METER READINGS:

Product Water Flow Meter: _____ US Gallons Per Hour or _____ Liters Per Hour

WATER QUALITY:

Feed Water Salinity: _____ ppm or Location of use: _____

Product Water Salinity: _____ ppm

Unusual occurrences or noises: _____

Section 3

System Operation

SYSTEM OPERATION NOTES:

The fresh water production of the Seafari 170 or 350 depends on six factors:

- o Feed Water Temperature
- o Feed Water Salinity
- o Feed Water Flow Rate
- o Operating Pressure
- o Characteristics of the individual R.O. Membrane Element
- o Condition of the individual R.O. Membrane Element

Feed water temperature and salinity vary depending upon location of operation.

Feed water flow is fixed on the Seafari 170 at .5 gallon per minute / 1.89 liters per minute; and on the Seafari 350 at 1.5 gallons per minute / 5.68 liters per minute, by design.

The only operator adjustment that remains is the operating pressure, which is adjusted at startup by the operator. There are two parameters, which are controlled by this single operator adjustment: Operating Pressure and resulting Product Water Flow.

The Operating Pressure is adjusted upward until the Seafari 170 System produces 7 gallons per hour / 26.8 liters per hour, or the Seafari 350 system produces 14.6 gallons per hour / 55.2 liters per hour. However, the maximum Operating Pressure allowed is 900 psi. Do not exceed 900 psi even though the system does not produce the specified amount of product water. The system automatically shuts down if the maximum Operating Pressure exceeds 950 psi.

External factors, such as Feed Water Temperature, Feed Water Salinity, or condition of the R.O. Membrane Element may cause the system to produce less than specified even though the Operating Pressure is at 900 psi.

OPERATION CAUTIONS:

Open all valves on the piping or hoses leading to and from the system.
 Check the Oil level in the High Pressure Pump.
 Check for any abnormalities such as leaks, damaged hoses, wires, and etc.

STARTUP PROCEDURE

1. **Open the Inlet Sea Cock Valve [2] fully.**
2. **Switch the electrical power to the system on at the circuit breaker.** The "POWER" lamp on the system Touch Pad will illuminate.
3. **Ensure that the back-pressure regulator valve [17] is fully open (counterclockwise).** This is not required and is commonly skipped on systems equipped with a Remote Control. Performing this step reduces wear and tear on the mechanical and electrical components.
4. **Press the "Start" switch.** This initiates the automatic start sequence. The automatic start sequence begins with the booster pump starting immediately and the high-pressure pump following after a brief delay.

or

Press the "Booster Pump" switch, then press "Start" switch. Pressing the booster pump switch starts just the booster pump. It continues running by itself until the start switch is pressed.

HIGH/LOW PRESSURE FAULT LAMP EXPLANATION:

Low Pressure fault: When the inlet pressure to the high-pressure pump falls below 6 psi, the "High/Low Pressure" lamp blinks. If the condition is not corrected, the system shuts down after 20 seconds. The Low Pressure switch monitors this condition caused by a dirty pre-filter, a closed Inlet Sea Cock Valve, or restriction at the Inlet Thru-Hull fitting or in the inlet feed line.

High Pressure fault: The High Pressure switch stops the system if pressure exceeds 950 psi.

After the cause of the fault condition has been corrected, press "Fault Reset" and repeat Steps 1 - 4 above.

5. Slowly adjust the backpressure regulator [17] until the system produces the specified product water gallon per hour flow at the Product Flow meter, but do not exceed 900 psi.

Seafari 170. Do not exceed 7 gph or 900 psi.

Seafari 350. Do not exceed 14.6 gph or 900 psi.

See "Temperature Effects Chart" and "Salinity Effects Chart" in Section 8 of this manual for expected pressure settings and production.

Colder Water: At sea water temperatures below 77° F, the Seafari must operate at a higher pressure to produce the specified amount of fresh water. As water temperature drops, the individual H₂O molecules are less active, and higher pressure is required to drive them through the membrane surface. Another result of lower temperature feed water is that the fresh water produced has a lower salt content. **Do not operate with feed water below 33° F / 1° C because the product water will freeze and cause mechanical failure and rupture of components within the system.**

Warmer Water: At water temperatures above 77° F, the Seafari operates at a lower pressure to produce the specified amount of fresh water. As water temperature rises, the individual H₂O molecules are more active and pass through the R.O. Membrane Element with less pressure. Higher temperatures also allow more salt to make its way into the fresh water. **Do not operate with feed water that exceeds 122° F / 50 C. High temperatures will cause structural damage to the R.O Membrane Element.**

6. If any abnormality develops, stop the system and correct the problem.
7. Check for unusual noises or other occurrences.

SHUTDOWN PROCEDURE

1. Observe and compare the performance of the system to the previously recorded new system initial readings in Section 2 of this manual. This allows the operator to monitor performance and spot deviations or deficiencies when they occur. This ensures a properly functioning system when it's needed. Make copies of and fill out the **DAILY OPERATION LOG SYSTEM READINGS** found at the end of this section and record daily system performance.
2. Open the Back Pressure Regulator Valve fully (counterclockwise).
3. Depress the "Stop" switch on the Touch Pad. If installed, the Fresh Water Flush (FWF) system is initiated when the "Stop" switch is pressed. The Fresh Water Flush lasts for 10 minutes. After the ten minutes, the fresh water flush stops, but it remains in FWF stand-by mode. In this stand-by mode, the fresh water flush repeats the ten-minute rinse every 7 days.
4. To cancel the Fresh Water Flush stand-by mode, press the "Stop" switch a second time ONLY if you wish to cancel the Fresh Water Flush stand-by mode. If the Fresh Water Flush stand-by mode is canceled by pressing the "Stop" switch a second time, the system will not be automatically rinsed every 7 days.
5. Turn off the electrical power source (circuit breaker) to the system ONLY if you do not want the system to automatically rinse every 7 days or if the system does not have the Fresh Water Flush Option installed. This eliminates the chance of inadvertently starting the system. Lockout/Tag Out must be used on the system circuit breaker when performing maintenance to the system.
6. Close the Inlet Sea Cock Valve [2]. This is a safeguard for vessel installations.
7. Refer to Chapter 4 for proper storage procedures. Section 4 describes the proper storage of the system for various time intervals.

DAILY OPERATION LOG SYSTEM READINGS

Make copies of this blank form. At each shut down of the Seafari 170 or 350 System record the following information. Retain these daily logs of the System performance for future reference and troubleshooting.

This information is valuable to the servicing technicians in providing technical support to the owner and future operators of the Seafari 170 or 350. Provide this information to service technicians when requesting technical assistance.

Serial Number: _____ Model Number: Seafari 170 _____; or Seafari 350 _____

Name of Operator: _____ Date: _____

System Power: _____ Volts AC, _____ Hz; or _____ Volts DC

Feed Water Temperature: _____ ° Fahrenheit or _____ ° Celsius

Hour Meter Reading: _____ Hours

PRESSURE GAUGE READINGS:

Low Pressure Gauge Reading: _____ psi High Pressure Gauge reading: _____ psi

WATER FLOW METER READINGS:

Product Water Flow Meter: _____ US Gallons Per Hour or _____ Liters Per Hour

WATER QUALITY:

Feed Water Salinity: _____ ppm or Location of use: _____

Product Water Salinity: _____ ppm

Unusual occurrences or noises: _____

Horizon Reverse Osmosis Seafari 170 and 350
DAILY OPERATION LOG SYSTEM READINGS

Make copies of this blank form. At each shut down of the Seafari 170 or 350, record the following information. Retain these daily logs of the system performance for future reference and troubleshooting.

This information is valuable to the servicing technicians in providing technical support to the owner and future operators of the Seafari 170 or 350. Provide this information to service technicians when requesting technical assistance.

Serial Number: _____ Model Number: Seafari 170 _____; or Seafari 350 _____

Name of Operator: _____ Date: _____

System Power: _____ Volts AC, _____ Hz; or _____ Volts DC

Feed Water Temperature: _____ ° Fahrenheit or _____ ° Celsius

Hour Meter Reading: _____ Hours

PRESSURE GAUGE READINGS:

Low Pressure Gauge Reading: _____ psi High Pressure Gauge reading: _____ psi

WATER FLOW METER READINGS:

Product Water Flow Meter: _____ US Gallons Per Hour or _____ Liters Per Hour

WATER QUALITY:

Feed Water Salinity: _____ ppm or Location of use: _____

Product Water Salinity: _____ ppm

Unusual occurrences or noises: _____

Section 4
System Storage
&
R.O. Membrane Element Cleaning

System Storage and Cleaning

4.1 R.O. MEMBRANE ELEMENT HANDLING & SYSTEM STORAGE CAUTIONS:

- 1. TEMPERATURE:** Never store the R.O. Membrane Element or Membrane/Vessel Assembly in direct sunlight. Never expose the R.O. Membrane Element or Membrane/Vessel Assembly to storage temperatures above 120° F / 50 C or below 32° F / 0 C. High temperatures cause up to 40% loss of production from the R.O. membrane element. This damage is irreversible. Freezing temperatures cause mechanical damage to the system and irreversible damage to the R.O. membrane element.
- 2. DRYING OUT:** Never allow the R.O. membrane element to dry out, as 40% production loss occurs. This membrane damage may be irreversible. Some, but not all, production may be restored by saturating the R.O. Membrane Element in product water for several days and then operating the system using product water feed into the system for a continuous 48 hour period. The R.O. membrane element must remain wet at all times.
- 3. BIOLOGICAL FOULING:** Protect the R.O. membrane element from biological fouling. Production loss occurs if the element becomes fouled by biological slimes. Some, but not all, production may be restored after cleaning.
- 4. CHEMICAL FOULING:** Never expose the R.O. Membrane Element to chemicals other than those supplied by HRO Systems. Use caution when operating the system in harbors that may be polluted with chemicals, oil, or fuel. Chemicals may damage the R.O. Membrane Element beyond repair.
- 5. STORAGE:** The dark and moist interior of a membrane element is an excellent breeding ground for microorganisms. Simply operating the system does not protect the R.O. Membrane Element from up to 40% production loss due to biological fouling. During short-term shutdowns, the system must be rinsed as explained in the following pages. During

long-term shutdowns, the system must be rinsed as well as chemically treated as explained later in this chapter.

- 6. NEW SYSTEM STORAGE:** If you are storing the system for longer than 3 months, do not install the membrane. Install the membrane prior to actual use. If storage of the new system is longer than 3 months, the system must be rinsed with fresh water and stored with fresh storage solution every 3 months, otherwise biological fouling and/or drying out damages the R.O. Membrane Element.

On the following page are two illustrations that show the flow of water in a Once-Through-Rinse operation and in a Closed Loop operation. These illustrations may be referred to during the Rinse, Clean, and Storage procedures.

Once Through Configuration

This is used to Rinse System with Fresh Water and also to Discharge the contents of the cleaning solution bucket.

SEAFARI 170/350 U.S. GPD

CLEAN RINSE OPERATION

Once Through Configuration

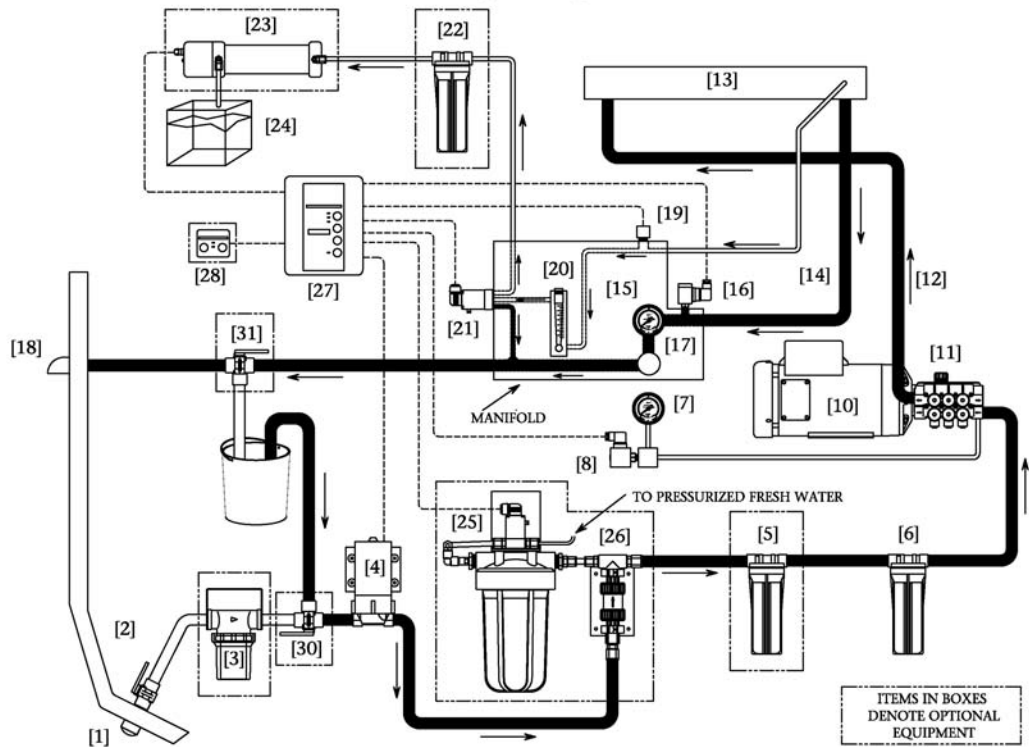

Closed Loop Configuration

This is used to Circulate Cleaning or Storage Solution through the system.

SEAFARI 170/350 U.S. GPD

CLEAN RINSE OPERATION

Closed Loop Configuration

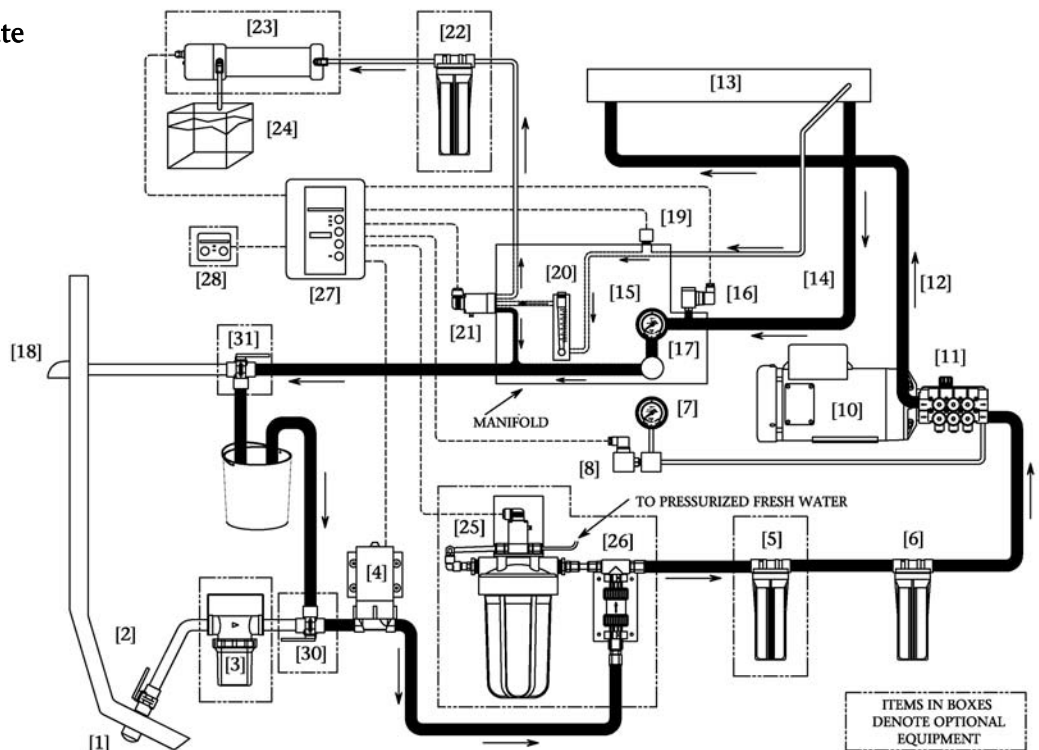

This Illustration demonstrates a Once Through Rinse Configuration

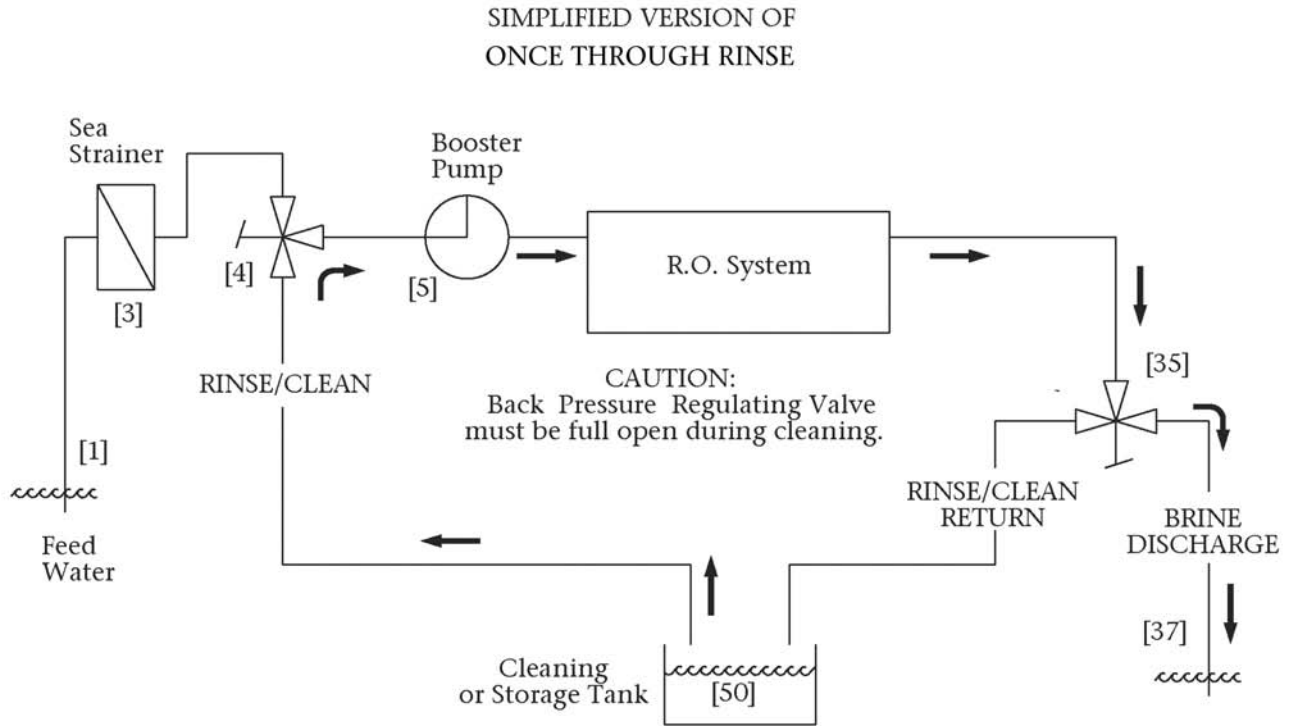

This Illustration demonstrates a Closed Loop Configuration

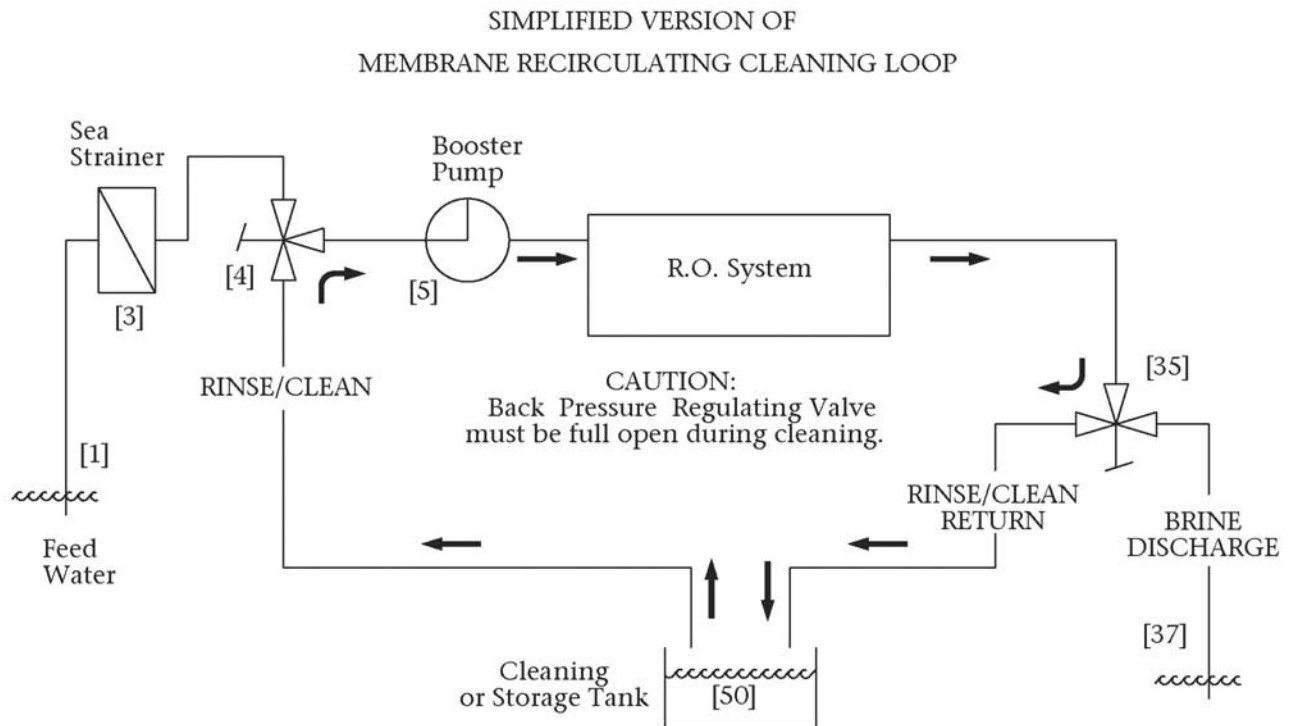

When the instructions within this section state “configure for Once Through Rinse”, proceed as follows:

- a. Configure the Suction line for a Once Through Configuration as illustrated in the drawings at the TOP of pages 4 and 5 of this section. Disconnect the outlet line from the Sea Strainer [3] and place it in the container or bucket. Or if the system is equipped with an Optional Inlet Clean/Rinse 3-way ball valve [30] between the Sea Strainer [3] and Booster Pump [4], then position this valve to draw from the bucket.

also

- b. Configure the Brine Discharge line for a Once Through Configuration as illustrated in the drawings at the TOP of pages 4 and 5 of this section. Connect the Brine Discharge Line from the system to the Thru-Hull over board discharge fitting [18], normal connection for normal operation. Or if the system is equipped with an Optional Discharge Clean/Rinse 3-way ball valve [31] between the system and the Thru-Hull over board discharge fitting [18], then position this valve to discharge through the Thru-Hull fitting, normal connection for normal operation

When the instructions within this section state “configure for Closed Loop” proceed as follows:

- a. Configure the Suction line for a Closed Loop Configuration as illustrated in the drawings at the BOTTOM of pages 4 and 5 of this section. Disconnect the outlet line from the Sea Strainer [3] and place it in the container or bucket. Or if the system is equipped with an Optional Inlet Clean/Rinse 3-way ball valve [30] between the Sea Strainer [3] and Booster Pump [4], then position this valve to draw from the bucket.

also

- b. Configure the Brine Discharge line for a Closed Loop Configuration as illustrated in the drawings at the BOTTOM of pages 4 and 5 of this section. Disconnect the Brine Discharge Line from the Thru-Hull over board discharge fitting [18] and place it in the container or bucket. Or if the system is equipped with an Optional Discharge Clean/Rinse 3-way ball valve [31] between the system and the Thru-Hull over board discharge fitting [18], then position this valve to return to the container or bucket.

4.2 SHORT-TERM SHUTDOWN: A short-term shutdown is defined as a period of time in which the system is not utilized for up to four weeks. An effective short-term protection for the system and R.O. membrane element is a Fresh Water Rinse of the entire system with fresh water (product water from the system). This prolongs the system life by minimizing electrolysis and retarding biological growth.

NOTE: If the system is equipped with an automatic Fresh Water Flush Accessory, then it is not necessary to read this Chapter 4.2. The Automatic Fresh Water Flush Accessory rinses the system every 7 days automatically as described in the previous Section 3. However, see “Winterizing and Freezing” note below.

WINTERIZING AND FREEZING

TEMPERATURE STORAGE NOTE: If the system is exposed to freezing temperatures, DO NOT activate the Automatic Fresh Water Flush. Instead, perform a Manual Fresh Water Rinse as described below. Deactivate the Automatic Fresh Water Flush cycle by pressing the “Stop” switch twice (2 times).

MANUAL FRESH WATER RINSE

PROCEDURE: Follow the directions below if the system is not equipped with an Automatic Fresh Water Flush accessory. This procedure displaces the system feed water with fresh water and allows a short-term shutdown for up to four weeks. Five gallons (19 liters) of fresh product or potable water is required for the fresh water rinse.

1. Close the Inlet Sea Cock Valve [2].
2. Fill a 5-gallon container with clean, fresh water.
3. Configure the system for a **Once Through Rinse** as illustrated at the TOP of pages 4 and 5 of this Section.
4. Fully open the Back Pressure Regulating Valve [17] counter clockwise.
5. Press the “Start” switch. The fresh water rinses the system and discharges out to waste [18].

6. Apply 200 psi of pressure to the system by turning the Back Pressure Regulator [17] clockwise. This allows the system to produce a minimal amount of product water, which ensures that the product water line remains wet.
7. Just prior to depleting the rinse water from the bucket, fully open the Back Pressure Regulator Valve [17] counter clockwise and stop the system.

IN NON FREEZING TEMPERATURES, THE SYSTEM MAY NOW BE LEFT UNATTENDED FOR SEVERAL WEEKS. HOWEVER, IF THE SYSTEM WILL BE EXPOSED TO FREEZING TEMPERATURES, CONTINUE WITH THE FOLLOWING PROCEDURES:

8. Again, fill a 5-gallon container with clean, fresh water. Add twenty percent (1 gallon / 4 liters) food grade glycerin (propylene glycol) to the Storage Chemical Solution. This prevents the water in the system from freezing.
9. Configure the system for a **Once Through Rinse** as illustrated at the TOP of pages 4 and 5 of this Section.
10. Fully open the Back Pressure Regulating Valve [17] counter clockwise.
11. Press the "Start" switch. The fresh water rinses the system and discharges out to waste [18].
12. Just prior to depleting the rinse water from the bucket, fully open the Back Pressure Regulator Valve [17] counter clockwise and stop the system. Deactivate the Automatic Fresh Water Flush Cycle by pressing the "Stop" switch twice (2 times).
13. Reconfigure the system for normal operation by reconnecting the Sea Strainer [3] outlet line, or reposition the Inlet Rinse/Clean 3-way ball valve [30] to normal operation position. The system is now exposed to fresh rinse water and may be left unattended for up to four weeks.

14. Remove product water from the Post Filtration Section
 - a. Open the Charcoal Filter Bowl and drain the product water from it.
 - b. Disconnect the bottom tube fitting from the Ultra Violet Sterilizer and drain the product water from it.
 - c. Open the pH Neutralizer Filter Bowl and drain the product water from it.
 - d. Disconnect or Close the valve from the fresh water tank to the Automatic Fresh Water Flush and drain the Fresh Water Flush Charcoal Filter bowl.

The Manual Fresh Water Rinse Procedure should be repeated every four weeks if the system is not in use and if the system does not have the Optional Automatic Fresh Water Flush..

4.3 LONG TERM SHUTDOWN: A Long Term or Prolonged Shutdown is a period in which the system goes un-used for longer than three months, depending on conditions. For this interval, the system should first be rinsed with fresh water then stored with system and Membrane Element Storage Chemical (HRO SC). This chemical inhibits bacterial growth while maintaining the high flux and salt rejection of the R.O. Membrane Element. The Long Term Shutdown procedure requires 10 gallons (38 liters) of potable water. Follow the directions listed below.

WINTERIZING AND FREEZING

TEMPERATURE STORAGE NOTE: If the system is exposed to freezing temperatures, add twenty percent (1 gallon / 4 liters) food grade glycerin (propylene glycol) to the Storage Chemical Solution. This prevents the water in the system from freezing.

1. Close the Inlet Sea Cock Valve [2].
2. Replace the Pre-filtration Cartridge [6] with a new Horizon Reverse Osmosis Pre-filtration Element.
3. Fill a clean 5-gallon container with non-chlorinated product water.

4. Configure the system for a **Once Through Rinse** as illustrated at the TOP of pages 4 and 5 of this Section.
5. Open the Back Pressure Regulating Valve [17] full open counter clockwise.
6. Start the system. The rinse water rinses the entire system and discharging to waste [18].
7. Apply 200 psi of pressure to the system. This produces a minimal amount of product water, which ensures the product water line remains wet.
8. Just prior to depleting the rinse water from the bucket, fully open counter clockwise the Back Pressure Regulator Valve [17] and stop the system (Press stop button twice to abort Fresh Water Flush Cycle).
9. Fully open the Back Pressure Regulating Valve [17] counter clockwise.
10. Fill the 5-gallon bucket with product water. Add 4 ounces (1/6th bottle) of HRO SC Storage Chemical to the water in the plastic bucket. **DO NOT ADD ANY OTHER CHEMICAL.**
11. Mix and thoroughly dissolve the solution in the container.
12. If the system will be exposed to freezing temperatures, add 1 gallon (4 liters) food grade glycerin (propylene glycol) to the 5 gallons of Storage Solution. This prevents the water in the system from freezing. **DO NOT ADD ANY OTHER CHEMICAL.**
13. Configure the system for a **Closed Loop Configuration** as illustrated at the BOTTOM of pages 4 and 5 of this section.
14. Operate the system by pressing the "Start" Switch. The Storage Chemical Solution flows from the container through the system and back into the container in a Closed Loop configuration. **Do not pressurize the system; leave the Back Pressure Regulator [17] fully open..**
15. After approximately 10 minutes of circulation, stop the system (Press stop button twice to abort Fresh Water Flush Cycle).
16. Configure the System for a **Once Through Rinse** as illustrated at the TOP of pages 4 and 5 of this Section.
17. Start the system, which discharges the Storage Chemical Mixture through the Brine Discharge Thru Hull Fitting [18].
18. Stop the system just before depleting the Storage Chemical Solution from the tank. Press the Stop switch twice to abort the Automatic Fresh Water Flush cycle.
19. Reconfigure the system for normal operation by reconnecting the Sea Strainer [3] outlet line for normal operation. Or if the system is equipped with a Inlet Clean/Rinse 3-way ball valve [30], then position this valve to the normal operating position towards the Sea Strainer.
20. **WINTERIZING AND FREEZING TEMPERATURE STORAGE NOTE:** If the system is exposed to freezing temperatures, remove product water from the Post Filtration Section
 - a. Open the Charcoal Filter Bowl and drain the product water from it.
 - b. Disconnect the bottom tube fitting from the Ultra Violet Sterilizer and drain the product water from it.
 - c. Open the pH Neutralizer Filter Bowl and drain the product water from it.
 - d. Disconnect or Close the valve from the fresh water tank to the Automatic Fresh Water Flush and drain the Fresh Water Flush Charcoal Filter bowl.

The system may now be left unattended for up to 3 to 6 months. With ideal conditions including a relatively new R.O. Membrane Element, a clean system prior to storage, cool temperatures, and no leakage of storage chemical within the system, it provides protection for up to 6 months. Adverse conditions may provide less protection. Evaluate these factors before determining the proper interval between repeated rinsing and storage periods.

4.4 R.O. MEMBRANE ELEMENT CLEANING PROCEDURES

Do not arbitrarily clean the R.O. Membrane in a NEW system. If a New system experiences low production or high salinity, then it should be operated for up to 48 hours *continuously* to clear and saturate the R.O. Membrane Element and product water channel. If a new system still experiences low production and/or high salinity after 48 hours of **continual operation**, then contact the factory.

The membrane element requires cleaning from time to time. Biological growth and salt accumulation eventually make replacement necessary. The frequency of required cleaning depends on the amount of production and salt rejection loss resulting from normal use. In order to properly assess performance changes, it is important to maintain daily log readings for comparison.

During performance comparisons, Feed Water Temp, Feed Water Salinity, and System Operating Pressure must be taken into consideration (See Section 8) and compensated for. After compensations, a 10% decline in productivity (GPH Flow) and/or a 10% increase in salt passage indicate that the R.O. Membrane Element may require cleaning.

If production rate has dropped dramatically since the last time the system was used, this may be due to drying out of the R.O. Membrane Element and/or fouling during storage. If the system has not been used for several months and the production rate has dropped dramatically since the last time used, try operating the system for 48 or more continuous hours to saturate the Product Water Channel within the R.O. Membrane Element.

If production rate drops dramatically from one day to another, this may be due to chemical attack which is not cleanable. Sewage chemicals or petroleum products cause irreparable damage to the R.O. Membrane Element. Suspended solids fouling results from silt, coral dust, river or inland waterway debris, or other small solid matter.

4.4.1 R.O. MEMBRANE ELEMENT CLEANING WATER AND CHEMICAL REQUIREMENTS:

1. The system must be rinsed with fresh water before any cleaning procedure.
2. The process of rinsing and cleaning the R.O. Membrane Elements requires 20 gallons / 76 liters of fresh non-chlorinated product water.
3. The Horizon Reverse Osmosis cleaning compounds are designed to clean in a closed loop configuration moderate fouling from the R.O. membrane element. If the R.O. Membrane Element is excessively fouled and in-field cleaning is not successful, the R.O. Membrane Element may be returned to Horizon Reverse Osmosis or to one of Horizon Reverse Osmosis' many Service Dealers for professional chemical cleaning. If your membrane requires professional cleaning, please contact Horizon Reverse Osmosis for a Return Authorization Number, price quotation, and return instructions.
4. **HRO CC-1, Membrane Cleaning**
Compound "# 1" is an alkaline cleaner designed to clean biological fouling and slight oil fouling from the R.O. Membrane Element. Biological fouling is usually the first cause of the R.O. Membrane Element fouling. The system is constantly exposed to seawater and biological growth occurs from the first day forward. If exposed to seawater and left to sit, the R.O. Membrane Element becomes fouled even with no actual system use. This fouling is minimized with fresh water rinsing whenever the system is not in use.
5. **HRO CC-2, Membrane Cleaning**
Compound "# 2" is an acid cleaner designed to clean calcium carbonate and other mineral deposits from the R.O. Membrane Element. Mineral fouling is a slow process, which takes place during use of the system. Therefore, if the system has relatively few hours of use yet shows signs of R.O. Membrane Element fouling then that fouling is likely biological fouling. If the system has in excess of 1000 hours of use, then there may be some mineral fouling combined with biological fouling.

6. **HRO CC-3, Membrane Cleaning**
 Compound "# 3" is used for iron fouling. It is not included in the HRO Membrane Cleaning Chemical kit. If the system's R.O. membrane element is fouled with rust from iron piping, then HRO CC-3 may be used for effective removal of light or moderate rust fouling. Heavily rust fouled RO Membranes may not be recoverable as rust not only fouls the Membrane Element but also damages the membrane surface.

CAUTION: DO NOT MIX DIFFERENT CLEANING CHEMICALS TOGETHER. DO NOT USE DIFFERENT CLEANING CHEMICALS TOGETHER AT THE SAME TIME. MIX THE CLEANING CHEMICALS SEPARATELY AND USE THEM SEPARATELY.

4.4.2 R.O. MEMBRANE ELEMENT CLEANING INSTRUCTIONS:

Product Water Required, in U.S. Gallons for Cleaning of the R.O. Membrane Element:

Chemical	Rinse water required	Cleaning water required	Second Rinse water required	Final Rinse water required	Total water required
CC-1	5	5	5	5	20
CC-2	5	5	5	5	20
CC-3	5	5	5	5	20

1. Close the Inlet Sea Cock Valve [2].
2. Replace the Pre-filtration Cartridge with a new HRO Systems supplied Pre-filtration Element.
3. Configure the system for a **Once Through Rinse** as illustrated at the TOP of pages 4 and 5 of this Section.
4. Fill the 5-gallon container full with non-chlorinated product water. The bucket must contain enough product water to rinse the system until all of the feed water is displaced.
5. Open the Back Pressure Regulating Valve [17] fully open counterclockwise.

6. Operate the system by pressing the "Start" switch. The rinse water rinses the entire system and discharges out to waste.
7. Just prior to depleting the rinse water from the 5-gallon container, stop the system.
8. Fill the 5-gallon container with product water. **NOTE: FOR OPTIMUM CLEANING RESULTS, USE WATER BETWEEN 90° F-110° F / 32° C –43° C. DO NOT EXCEED 120° F / 50 C.**
9. Add 6 ounces (1/4 bottle) of either the HRO CC-1, CC-2, or CC-3 Cleaning Chemical to the water in the plastic bucket. **USE ONLY ONE CHEMICAL AT A TIME.**
10. Mix and thoroughly dissolve the solution in the container.
11. The ratio for the Membrane Cleaning Chemical (CC) is one bottle per 20 gallons of product water.
12. Configure the system for a **Closed Loop Configuration** as illustrated at the **BOTTOM** of pages 4 and 5 of this Section.
13. Press the "Start" switch to begin circulating the Cleaning Chemical solution from the container through the system and back into the container. **Do not pressurize the system; leave the Back Pressure Regulator Valve [17] fully open.**
14. After approximately 60 minutes of circulation, stop the system (Press the stop button twice to abort the Fresh Water Flush Cycle). **NOTE: If time permits, for best cleaning results, allow the cleaning solution to sit in the system for 4 to 6 hours and then reticulate the solution for an additional 20 minutes. This will allow the solution to soak, dislodge, and dissolve fouling.**
15. Empty the 5-gallon container by reconfiguring the system for a **Once Through Rinse** as illustrated at the TOP of pages 4 and 5 of this Section.

16. Press the "Start" switch to discharge the solution out the Brine Discharge Thru Hull Fitting [18].
17. Just prior to depleting the Cleaning Chemical solution from the container, stop the system (Press the stop button twice to abort the Fresh Water Flush Cycle).
18. Fill the 5-gallon container full with non-chlorinated product water.
19. Again, configure the System for a **Closed Loop Configuration** as illustrated at the BOTTOM of pages 4 and 5 of this section.
20. Press the "Start" switch to circulate the water from the container, through the system, and back into the container. Continue rinsing for 20 minutes.
21. After 20 minutes stop the system by pressing the "Stop" switch (Press the stop button twice to abort the Fresh Water Flush Cycle).
22. Empty the 5-gallon container by again reconnecting the Brine Discharge line to the normal position as described in step 15.
23. Press the "Start" switch to discharge the rinse water out the Brine Discharge Thru Hull Fitting [18].
24. Just prior to depleting the rinse water from the 5-gallon container, stop the system (Press the stop button twice to abort the Fresh Water Flush Cycle).
25. Fill the 5-gallon container with non-chlorinated product water.
26. Start the system to begin final rinsing of the System, and discharging out the Brine Discharge Thru Hull Fitting to waste.
27. Just prior to depleting the Final Rinse Water from the container, stop the system (Press the stop button twice to abort the Fresh Water Flush Cycle).

The System is now ready for additional cleaning, Storage, or use.

28. If further membrane cleaning is necessary, repeat Steps 8 through 27 for each additional cleaning.
29. If cleaning is completed and the system is to be stored:
 - a) Press the "stop" switch once to place the Fresh Water Flush in the stand-by mode
 - b) Reconnect the system's Suction and Discharge Lines to normal operating position.
 - c) Leave the Inlet Seacock Valve in the closed position.
30. If cleaning is complete and the system will be operated again within a short period of time:
 - a) Reconnect the system's Suction and Discharge Lines to normal operating position.

Section 5

Troubleshooting of Abnormalities

Troubleshooting

This section deals with abnormal occurrences of the Seafari system. Some occurrences may have many different causes. For each symptom, one or more causes are given. In turn, each cause has one or more corresponding tests to help identify whether the cause of the occurrence is the correct one. When the test(s) has confirmed the source of the problem, the appropriate remedy is given to correct it.

There may be more than one cause of a problem. In the following guide, when there is more than one cause of a problem, the causes are listed in the most likely to occur order. The tests given are designed to determine whether the cause of the problem is the correct one. When diagnosing the causes of a problem in this case, eliminate the listed causes one by one until the correct cause is found. Then the appropriate remedy is performed. Diagnosing and correcting the various occurrences in this manner makes troubleshooting easier and less time consuming.

The second page of this section illustrates a flowchart that provides a roadmap to the subsystem likely to be responsible when the system does not work. This is yet another tool to determine where to start.

Troubleshooting and subsequent correction or repair will require understanding of:

- Electrical Circuits
- Electronic Circuits
- Electric Motors
- Hydraulic Systems
- Liquid Pressures and Flows
- Electro Mechanical Systems
- Mechanical knowledge and skills

Do not attempt troubleshooting and/or subsequent correction or repair if you are not familiar with or are not proficient in the above fields of expertise.

USE CAUTION WHEN TROUBLESHOOTING. DO NOT PERFORM MAINTENANCE UNLESS:

1. The System Feed Water Sea Cock Valve [2] is closed.
2. The system main electrical disconnect switch is switched "OFF", LOCKED, and TAGGED.
3. Chapter 9, "EXPLODED PARTS VIEWS" of the USERS MANUAL is available.

CAUTION: ELECTRICAL SHOCK HAZARD. A Volt / Ohm Meter will be necessary. The following procedures expose the technician to High Voltage and electrical shock hazard. Only attempt this if you are a qualified electrician and only if surrounding conditions are safe.

A. SYSTEM SHUTS DOWN DURING OPERATION:

1. NUMBER ONE REPORTED PROBLEM IS “THE SYSTEM DOESN’T WORK”!

We can’t help with this one unless you give us more information, or allow us to ask an unlimited number of questions.

2. NUMBER TWO REPORTED PROBLEM IS: “System Shut Down By Itself & High/Low Pressure Lamp is Illuminated.”

- a. Press Reset Fault Switch to clear the electronics.
- b. While observing Low and High Pressure Gauges Start System,
 1. If High Pressure Gauge increases beyond 950 PSI and System shuts down, then Press Reset Fault and check the Brine Discharge Section as well as the Product Line Section:
 - o Open Back Pressure Regulator Valve full open counter clockwise
 - o Open all valves on the Brine Discharge Line (It is preferred and recommended that there are no valves on the Brine Discharge Line).
 - o No kinks or blockages in the Brine Discharge Line
 - o No kinks or blockages in the Product Water Line
 2. If Low Pressure Gauge decreases to near or below 6 PSI, check the inlet line and associated components prior to the High Pressure Pump Inlet:
 - o Inlet Sea Cock Valve must be fully open
 - o Check for air suction leaks at all components and fittings prior to the Booster Pump
 - o Sea Strainer Mesh Screen clean manufacturing or installation debris and check for air suction leaks
 - o Prefilter Element clean manufacturing or installation debris
 - o Plankton Filter Element clean manufacturing or installation debris
 - o No kinks or blockages in the inlet line and check for air suction leaks
 - o Ensure that the Booster Pump is operational and delivering flow and pressure
 - o Inlet Thru-Hull Fitting clean manufacturing or installation debris and check for air suction leaks
 - Caulking compound within the opening
 - Shipping cover or tape below the hull in the water
 - Casting slag on the “fingers” below the hull in the water or within the orifice
 - Plastic bag or other debris in the water below the hull in the water
 3. Have patience with this one, and please read this carefully: Debris may plug up the Prefilter Element causing the system to shut down. After shut down, that same debris may settle off of the prefilter element and down into the prefilter housing bowl. Re-starting of the system may initially give normal readings. However, after a short period of time, the debris will stir up and once again clog the prefilter element causing the system to shut down due to low pressure.

Another cause may be a plastic bag or other debris attached to the thru-hull inlet fitting that finds its way over the thru-hull inlet then drops away when the system shuts down.

Still another cause may be an air suction leak at or prior to the Booster Pump (suction line at or prior to the Inlet of the Booster Pump). Within up to 10 minutes of operation, if the Low Pressure Gauge gradually decreases to near or below 6 PSI, check the inlet line and associated components prior to the High Pressure Pump Inlet:

- o Sea Strainer Mesh Screen clean all debris and check for air suction leak
- o Prefilter Elements replace

- Plankton Filter Element clean debris from screen
 - Inlet Thru-Hull Fitting for debris, underneath the boat, and check for air suction leaks.
 - Inlet Sea Cock Valve must be full open and check for air suction leaks
 - No kinks or blockages in the inlet line and check for air suction leaks from each fitting.
 - Ensure that the Booster Pump is operational and delivering flow and pressure
4. If system shuts down due to low or high pressure prematurely, then either the Low Pressure Switch or the High Pressure Switch may require adjustment or replacement. Refer to High and Low Pressure Switch Troubleshooting as well as High and Low Pressure Gauge Troubleshooting.
- 3. System Shut Down By Itself & High/Low Pressure Lamp is NOT Illuminated and the system's power lamp is illuminated**
- a. Voltage may have been interrupted causing the system to shut down.
 - b. Check Voltage at the system inside the Control Panel. The system must receive adequate voltage at start up and during operation in order for it to operate normally.
 - 12 VDC Systems shut down by design when the voltage falls below 11 VDC
 - 24 VDC Systems shut down by design when the voltage falls below 22 VDC
 - AC systems shut down by design when the voltage falls below 10% of the set voltage
 - c. Check power cable wire size from the power source to the system to ensure that it is not undersized and causing voltage drop to the system. Refer in section 2 of this manual.
 - d. Check power cable wire connections from the power source to the system to ensure that they are tight.
- 4. System Shut Down By Itself, NO lamps are illuminated, and the system does not start when the start switch is pressed:**
- a. Check power source circuit breaker.
 - If the breaker has tripped and if this is a continual problem, check circuit breaker amperage rating to ensure that the proper circuit breaker has been installed.
 - Occasionally a circuit breaker can be "weak" or defective causing premature trip.
 - Have a qualified electrician check the circuit breaker with a full rated load to test its integrity.
 - Check Power Wire Size to ensure that it is proper for the amperage rating of the system. Undersize wire will cause voltage drop and increased current.
- 5. System Shuts Down when the operating pressure is less than 950 PSI and the High/Low Pressure Fault Lamp is illuminated:**
- a. Check the High Pressure Switch continuity. The High Pressure switch is "normally closed" and "opens" above 950 PSI.
 - Shut the system off, remove the leads from the High Pressure switch, and using an ohm meter ensure that the switch circuit is "closed".
 - If the switch circuit is "open", adjust the switch per instructions in the maintenance section of this manual.
 - b. Inspect the pressure gauge orifice inside the High Pressure Gauge port and dislodge debris within the orifice by cleaning or opening the hole with a small drill bit 1/32 nd inch / 1 mm diameter. Replace Gauge if necessary.

~~~~~  
**B. PRESSURE READINGS, PRESSURE GAUGES, PRESSURE SWITCHES ABNORMALITIES:**

**1. Low Pressure Gauge reading is below 6 PSI but system remains operating:**

- a. Inspect the pressure gauge orifice inside the Low Pressure Gauge port and dislodge debris within the orifice by cleaning or opening the hole with a small drill bit 1/32 nd inch / 1 mm diameter. Replace Gauge if necessary.
- b. Check the Low Pressure Switch continuity. The low pressure switch is “normally open” and “closes” above 6 PSI.
  - o Shut the system off, remove the leads from the low pressure switch, and using an ohm meter ensure that the switch circuit is “open”.
  - o If the switch circuit is “closed”, adjust the switch per instructions in the maintenance section of this manual.

**2. System remains in operation when the operating pressure is above 950 PSI.**

- a. High Pressure Switch has drifted from factory setting.
  - o Operate System and pressurize to 950 psi. Adjust High Pressure switch to “open” at 950 PSI. Refer to Section 6 of this manual.
  - o Replace switch if necessary.

~~~~~  
C. PRODUCT WATER FLOW AND PRODUCT WATER QUALITY:

1. The System is operating at 850 psi and is not producing specified product water flow of 7 Gallons Per Hour for the Seafari 170 or 14.5 Gallons Per Hour for the Seafari 350:

- a. Feed Water salinity is greater than 35,000 PPM.
 - o Higher salinity Feed Water Requires higher Pressure to make rated flow. Refer to Salinity Effects chart in Section 8 of this manual to identify expected pressure for Higher Salinity Feed Waters. Do not exceed 900 psi operating pressure.
- b. System Feed Water temperature is lower than 77° Fahrenheit / 25° degrees Celsius.
 - o Lower temperature feed water requires higher operating pressure to make rated flow. Refer to Temperature Effects chart in Section 8 of this manual to identify expected pressure for lower temperature Feed Waters. Do not exceed 900 psi operating pressure.
- c. NEW System Initial Commissioning
 - o RO Membrane Element may have dried out between the time of installation and the time of commissioning. Contact the factory if this time period is uncertain. If this may be the situation, then operate system pressurized for 48 hours continuous to saturate and hydrate the R.O. Membrane Element. Only do this if it is known that the system was shipped months prior to installation, and commissioning was performed months after installation, or if it is known that the R.O. Membrane Element has dried out.
- d. RO Membrane Element has been in use for a period of time and is fouled from use:
 - o If RO membrane element has been stored improperly, without proper flushing and/or storage solution, or if it has simply slowly degraded over time and use, then the Membrane may be fouled and cleaning may restore performance. If not, membrane should be replaced.

- e. Membrane has chemical fouling.
 - o If RO membrane element has been performing normally and the drop in production was sudden over one or two times of use, it may be chemically fouled by petroleum or other pollutants.
 - f. Membrane has dried out.
 - o If it is known that the R.O. Membrane Element has dried out, operate system pressurized for 48 hours continuous to saturate and hydrate the R.O. Membrane Element.
 - g. R.O. Membrane Element has been exposed to temperatures in excess of 140° F / 60° C
 - o Replace R.O. Membrane Element.
 - h. There may be a restriction in the product water line
 - o Ensure that any valve in the product water line is fully open. Note: It is preferred and recommended that there are no valves in the Product Water Line. Ensure that any valve in the product water line is tight, a loose or easily turning valve handle will move and reposition itself due to the movement and pounding of the boat.
- 2. System produces more than rated product water flow when operating from full seawater salinity of 35,000 ppm or higher and the operating pressure is 400 PSI or lower and the Product Water Quality Lamp is illuminated "red":**
- a. A mechanical failure exists in the R.O. Membrane and/or High Pressure Vessel.
 - o Cracked or broken RO Membrane Element product water tube which is caused by a blockage in the Product Water Line during operation
 - o Cracked End Plug in the High Pressure Vessel allowing Sea Water to mix with Product Water which is caused by over tightening of tapered pipe fittings into the End Plug
 - o Damaged or worn Product Water O-ring in the High Pressure Vessel End Plug
 - o Lamination failure within the R.O. Membrane Element which is caused by a blockage in the Product Water Line and/or air entrapment in the High Pressure Vessel is normally associated with mounting the High Pressure Vessels vertically rather than horizontally.
- 3. System produces expected rated product water flow with normal operating pressure after compensating for Feed Water Salinity and Temperature, and the Product Water Quality Lamp is illuminated "red" for an extended period:**
- a. It is helpful to use a portable TDS meter to determine if the problem is with the R.O. Membrane Element or with the Salinity Probe and Electronic monitoring system.
 - b. Damaged or worn Product Water O-ring at one of the End Plugs within the High Pressure Vessel is allowing Feed Water to mix with Product Water. This would usually also result in higher than normal Product Water Flow. However, a small nick in the O-ring may allow enough Feed Water to mix with the Product Water to cause the condition without resulting in a noticeable increase in Product Water Flow.
 - c. Crack in one of the End Plugs within the High Pressure Vessel is allowing Feed Water to mix with Product Water. This would usually also result in higher than normal Product Water Flow. However, a small crack may allow enough Feed Water to mix with the Product Water to cause the condition without resulting in a noticeable increase in Product Water Flow.
 - d. R.O. Membrane Element is fouled due to normal use and requires cleaning.

- e. Salinity Probe has debris on the probe causing the system to read poor water quality. Clean the Salinity Probe with a toothbrush.
- f. Salinity Monitor out of calibration.
 - o Test the actual Salinity of the product water using a portable TDS meter. The system switches from potable water to un-potable water at 800 PPM TDS. If the salinity of the Product Water is less than 800 PPM TDS, then calibrate the Salinity Monitor per instructions in Section 6 of this manual.

4. The Water Quality Indicator is Green (Potable water lamp) but the water has a definite salt taste.

- a. Blockage or pressure in excess of 55 psi is present in the brine discharge line.
 - o A blocked brine discharge line causes brine water to mix with product at the Diversion Valve. Flow through the flow meter will be normal because the flow meter is prior to the 3-way product water diversion valve.
 - o Ensure that the brine discharge line is free from kinks and that any valves installed in the brine discharge line are fully open.
- b. 3-way Product Water Diversion Valve requires mechanical adjustment or cleaning.
 - o Tube Connector fittings have been over tightened into the valve body causing the adjustment screws to move resulting in seawater bypass into the product water. Adjust the valve per the instructions in Section 6 of this manual.
- c. Salinity Probe has debris on the probe causing the system to read good water quality. Clean the Salinity Probe with a toothbrush.

5. Product Water is leaking from the Product Tubing when the Green (Potable water lamp) illuminates.

- a. Blockage or pressure in excess of 55 psi is present in the product outlet line from the system.
 - o Check all components and check for kinks or closed valves at and after the point of leakage.
 - o Charcoal Filter element is fouled, replace element
 - o pH Neutralizer element is fouled, replace element.
 - o 3-way Product Water Diversion Valve is blocked or inner ports are out of adjustment, adjust inner ports.

6. There is a Sulfurous odor (rotten eggs) in the product tank.

- a. Dirty Pre-Filtration Element.
 - o Dirty Pre-Filtration Elements allow biological matter to decay. When this biological matter decomposes, sulfur gas is released as a byproduct.
 - o Check and replace as necessary Prefiltration and Post Filtration Elements.
- b. Charcoal Filter Element requires replacement.
 - o Change the Charcoal Filter Element every 3 months.
- c. Product Tank is dirty or has biological growth in it.
 - o Clean and Chlorinate product tank.

7. The UV sterilizer is flickering or does not light. (*Ultra Violet light will damage skin and eyes. Do not look directly at the UV lamp*)

- a. UV lamp is weak due to length of time in use, in excess of 1,000 hours.
 - o Replace the UV lamp.

- b. The UV ballast is very sensitive to voltage changes.
 - o Ensure that the voltage supplied to the UV sterilizer is within 11.5 VDC to 13 VDC.

~~~~~

**D. 3-WAY PRODUCT WATER DIVERSION VALVE ABNORMALITIES:**

When the system is producing “unpotable” water and the Water Quality lamp is illuminated “red”, the 3-way Product Water Diversion Valve coil will not receive voltage from the controller. This allows the 3-way Product Water Diversion Valve to divert the “unpotable” water to the Brine Discharge.

When the system is producing “potable” water, and the Water Quality lamp is illuminated “green”, the 3-way Product Water Diversion Valve coil will receive 12 VDC from the controller. This allows the 3-way Product Water Diversion Valve to divert the “potable” water to the post filtration section and on to the boat’s potable water storage tank.

**1. The Water Quality lamp on the front of the Touch Pad is illuminated “green” safe water, however, the Diversion Valve does not divert potable water to the post filtration section and on to the boat’s potable water storage tank.**

- a. The Diversion Valve is not energizing, and the valve’s coil is cool to the touch after several minutes of operation with the Water Quality Lamp illuminated “green”.
  - o The 3-way Product Water Diversion Valve may have a defective solenoid coil.
  - o There may be a loose wire connection at the Control Printed Circuit Board or the solenoid’s din connector.
  - o The Control Printed Circuit Board may not be delivering 12 VDC to the solenoid.

**2. The 3-way Diversion Valve is receiving 12 VDC when the Water Quality lamp on the Touch Pad is illuminated “green” safe water and the valve’s solenoid coil is not defective. The valve’s solenoid coil is warm or hot to the touch, however the Diversion Valve does not divert potable water to the post filtration section and on to the boat’s potable water storage tank.**

- a. The Diversion Valve internal ports may have been moved by over tightening of the black tube fittings causing blockage internally and require adjustment.
  - o Remove Diversion Valve from the system and adjust ports.

~~~~~

E. HIGH PRESSURE PUMP ABNORMALITIES:

1. High Pressure Pump flow is normal when the system operating pressure is below 100 PSI, but the flow drops or becomes erratic and pulsates as pressure is applied.

- o Worn High Pressure Seals from normal use require replacement.
- o Worn High Pressure Pump valves, valve seats, valve springs and/or valve seat "O" rings are broken or worn due to normal use and are allowing internal by-passing. Repair the pump with a Valve and Seal Kit.

2. Pump is noisier than usual and pulsations are observed in hoses and gauges

- o Worn or broken Valve, Valve Spring, or Valve Seat. Repair the pump with a Valve and Seal Kit.

- Pump is cavitating and not receiving sufficient feed water at its inlet due to blockage prior to the pump's inlet port. Clear the blockage in the feed water line.

3. High Pressure Pump Leaks Oil

- Determine source of leak and replace appropriate associated seal.

4. High Pressure Pump leaks water between manifold and Drive End.

- Worn Inlet Packings due to normal use
- Worn Inlet Packings due to operation under a vacuum condition
- Worn Inlet Packings because pump has been operated dry without inlet feed water.
- Repair the pump with a Seal Kit.

5. If the High Pressure Pump electric motor fails to operate, follow these steps to isolate the problem.

- Ensure that the system is receiving proper power from the power source and the "POWER" LED is illuminated.
- Press "Start" switch to activate the motor. It will take approximately 10 seconds before the High Pressure Pump Motor starts. Do not press any other switch.
- Measure the AC voltage between terminals 4 and 5 (AC Systems) or 3 and 4 (DC systems) on the main terminal strip.
- If the voltage measured in the step 3 above matches the system voltage, then problems may be in the power cable attached to the motor or the motor internal wiring or windings.
- If low or no voltage is present in step 3 above, then check for proper operation of the High Pressure Pump Contactor. To deactivate the contactor, press the "Stop" switch twice. To activate the contactor again, press the "Start" switch.
- If the contactor is mechanically operating, but no voltage is present at the motor terminal (step 3 above), then the High Pressure Pump Motor contactor may be at fault.
- If the contactor does not operate mechanically, then measure the DC voltage between A1 and A2 terminals on the High Pressure Pump Motor contactor coil. It should read 12V DC when activated.
- If the contactor coil is receiving 12V DC but inoperative then the contactor's coil may be bad. Replace the contactor.
- If 12V DC is not present when the High Pressure Pump is activated, trace the orange and orange/black wires to the main circuit board and measure the DC voltage at the terminals. It should read 12V when activated.
- Confirm the "HIGH PRESSURE PUMP (HP)" LED (on the Control Printed Circuit Board) is illuminated when the High Pressure Pump is activated. When this LED is illuminated, the HP terminals on the Control Printed Circuit Board should receive 12 VDC. If it is not the case, replace the main circuit board.

~~~~~

**F. BOOSTER PUMP ABNORMALITIES:**

- 1. If the Booster Pump electric motor fails to operate, follow these steps to isolate the problem.**

- a. Ensure that the system is receiving proper power from the power source and the "POWER" LED is illuminated.
- b. Press "Booster Pump" switch to activate the motor. Do not press any other switch.
- c. Measure the AC voltage between terminals 1 and 2 on the main terminal strip in the controller.
- d. If the voltage measured in the step 3 above matches the system voltage, then problems may be in the power cable attached to the motor or the motor internal wiring or windings.
- e. If low or no voltage is present in step 3 above, then check for proper operation of the Booster Pump Contactor. To deactivate the contactor, press the "Stop" switch twice. To activate the contactor again press the "Booster Pump" switch.
- f. If the contactor is mechanically operating, but no voltage is present at the motor terminal (step 3 above), then the Booster Pump Motor contactor may be at fault.
- g. If the contactor does not operate mechanically, then measure the DC voltage between A1 and A2 terminals on the Booster Pump Motor contactor coil. It should read 12V DC when activated.
- h. If the contactor coil is receiving 12V DC but inoperative then the contactor's coil may be bad. Replace the contactor.
- i. If 12V DC is not present when the Booster Pump is activated, trace the yellow and yellow/black wires to the Control Printed Circuit Board and measure the DC voltage at the terminals. It should read 12V when activated.
- j. Confirm the "BOOSTER PUMP (BP)" LED (on the Control Printed Circuit Board) is illuminated when the Booster Pump is activated. When this LED is illuminated the BP terminals on the circuit board should receive 12 VDC. If it is not the case, replace the Control Printed Circuit Board.

~~~~~

Electrical Troubleshooting Guide

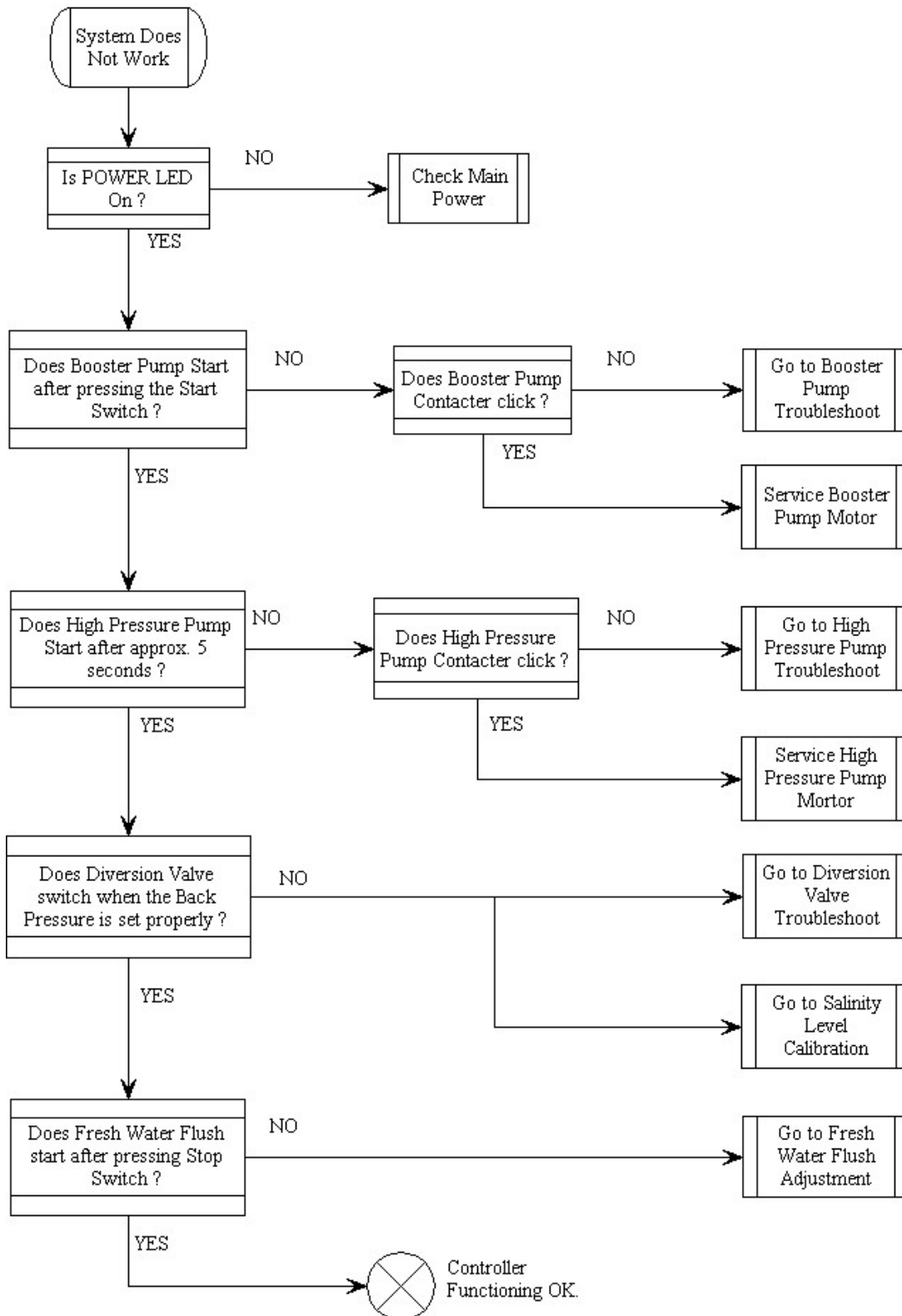

G. ELECTRICAL AND ELECTRONIC CIRCUIT ABNORMALITIES:

1. The Start Switch is pressed, but the system does not attempt to start.

- a. System is in Fresh Water Flush Mode, and the Fresh Water Flush Lamp on the Touch Pad is Blinking.
 - o Press Stop to exit Fresh Water Flush Mode. Press Start to operate the system.
- b. Hi/Low Pressure Fault Lamp on the Touch Pad is illuminated.
 - o Press Fault Reset on controller. Press Start to operate the system.
- c. The Power Lamp on the Touch Pad is not illuminated
 - o Reset the system circuit breaker.
 - o There is no main Power to the system from the Power Source, investigate, and correct.
- d. Microprocessor has locked up, no response from the Touch Pad.
 - o Turn main power off to the system at the power source circuit breaker for a minimum of 30 seconds to reset the microprocessor.
- e. Blown Fuse in controller.
 - o Check and Replace fuse if blown.
- f. Improper wiring.
 - o Ensure that system is wired correctly and that there are no loose wire connections.
- g. Inadequate power source to the system
 - o Ensure that the voltage does not drop below the industry standard of 10% of the full operating voltage set for the system. If the voltage drops below this standard during the system startup, the system will not start. High current is necessary to “excite” the electric motors. At the time of attempting to start the electric motors, they will consume high current. This may cause the voltage from the Power Source to drop dramatically for a fraction of a second which can be enough to cause the electronic circuit to shut off.
 - o For D.C. systems, it is instantaneous, and you will not hear or see this occur. D.C. systems ensure that the battery bank is fully charged and ensure that the wire size feeding the system is sufficient in diameter to carry the current without losing voltage. A.C. systems will usually result in the Generator loading down and the Generator R.P.M. slowing down.
 - o Provide adequate power to the system.
- h. Defective Start Switch on Touch Pad.
 - o Test with Substitute Touch Pad.
 - o Replace Touch Pad if one or more lamps or switches are found to be inoperable.

2. The Stop Switch is pressed, but the system does not stop.

- a. Microprocessor has locked up.
 - o Turn main power off to the system at the power source circuit breaker for a minimum of 30 seconds to reset the microprocessor.
- b. Defective Stop Switch on Touch Pad.
 - o Test with Substitute Touch Pad.
 - o Replace Touch Pad if one or more lamps or switches are found to be inoperable.
- c. Water damage to printed circuit board.
 - o Inspect Printed Circuit board for presence of water or corrosion from water.

- If board had had water spilled on it, remove board from system, flush with distilled water, and thoroughly dry with hair dryer. Place board in low humidity area for minimum 24 hours. Shake the board to ensure that no water is left on the board. Reinstall and attempt to operate the system. If there is any sign of corrosion from water damage, replace it.

3. Fuse in the controller blows at start up.

- a. Power source
 - There is either low voltage or high voltage into the system, below or above 10% of system set voltage.
 - Correct the improper power at the Power Source feeding the system.
- b. Defective Component that relies on the fuse for power.
 - Check the 3-Way Diversion Valve, Printed Circuit board, Fresh Water Flush, UV Sterilizer (If installed), or the Touch Pad.
 - Repair or replace Defective Component.

4. Product Water 3-way Diversion Valve does not switch to “safe water”, potable water.

- a. First go to Section D. **3-WAY PRODUCT WATER DIVERSION VALVE ABNORMALITIES:**
- b. Touch Pad Water Quality LED is illuminated RED “unpotable water”, and the 3-way Product Water Diversion Valve is not energized, it is sending the Product Water to Brine Discharge over board.
 - Using a hand held TDS Meter check the salinity of the Product Water. If the Salinity of the Product Water is greater than 800 PPM TDS, then the Salinity controller is reading properly and diverting the “unpotable water” Product Water by not energizing the 3-way Diversion Valve. This is normal and the problem lies in the R.O. Membrane Element, go to Section C. **PRODUCT WATER FLOW AND PRODUCT WATER QUALITY:**
- c. Touch Pad Water Quality LED is illuminated GREEN “safe water”, however the 3-way Product Water Diversion Valve is not energized, it is sending the Product Water to Brine Discharge over board.

CAUTION: ELECTRICAL SHOCK HAZARD. A Volt / Ohm Meter will be necessary. The following procedures expose the technician to High Voltage and electrical shock hazard. Only attempt this if you are a qualified electrician and only if surrounding conditions are safe.

With the system in operation and the Touch Pad Water Quality LED illuminating GREEN “safe water”, remove the Controller Enclosure front panel to expose the inside of the controller box components.

With the system in operation and the Touch Pad Water Quality LED illuminating GREEN “safe water”, measure the voltage at the terminals labeled 3-Way Product Water Diversion Valve. The voltage should be 12 VDC.

If no voltage is present replace the Control Printed Circuit Board.

If 12 VDC is present go to Section C. **PRODUCT WATER FLOW AND PRODUCT WATER QUALITY:**

5. Product Water salinity is confirmed (verified with a hand held TDS meter) to be less than 800 PPM TDS, however the Water Quality LED is illuminated RED “unpotable water”.

- a. Salinity Control requires calibration.
 - See Salinity Level Calibration in section 6 of this manual.

Section 6

Maintenance & Repair

Maintenance & Repair

Are you mechanically inclined?

Troubleshooting and subsequent correction or repair will require understanding of:

- Electrical Circuits
- Electronic Circuits
- Electric Motors
- Hydraulic Systems
- Liquid Pressures and Flows
- Electro Mechanical Systems
- Mechanical knowledge and skills

Do not attempt troubleshooting and/or subsequent correction or repair if you are not familiar with or are not proficient in the above fields of expertise.

USE CAUTION WHEN TROUBLESHOOTING. DO NOT PERFORM MAINTENANCE UNLESS:

1. The system Feed Water Sea Cock Valve [2] is closed.
2. The system main electrical disconnect switch is switched "OFF", LOCKED, and TAGGED.
3. Chapter 9, "EXPLODED PARTS VIEWS" of the USERS MANUAL is available.

CAUTION: ELECTRICAL SHOCK HAZARD. A Volt / Ohm Meter will be necessary. The following procedures expose the technician to High Voltage and electrical shock hazard. Only attempt this if you are a qualified electrician and only if surrounding conditions are safe.

Weekly Quick Check: The following steps ensure that potential problems are resolved preventing major repairs:

1. Inspect all fasteners for tightness including brackets, screws, nuts, and bolts. Pay special attention to the High Pressure Pump [11] and Electric Motor [10] since they are subject to increased vibration.
2. Ensure that Sea Strainer [3] & Plankton Filter [5], if either are installed, are clean and do not restrict flow.
3. Check the level of the High Pressure Pump [11] crankcase oil. The minimum oil level is the center of the sight glass, located at the side of the High Pressure Pump; the maximum oil level is at the top of the sight glass window. Use only HRO High Pressure Pump oil. **DO NOT USE MOTOR OR OTHER HYDRAULIC OIL.**
4. Clean any salt water or salt deposits from the system with a wet rag.
5. Check for fluid leaks; either oil from the High Pressure Pump or water from anywhere in the system.
6. Check all tubing and high-pressure hoses for wear and friction against abrasive surfaces. The hoses should not contact heated or abrasive surfaces.
7. Check Inlet Pressure to the High Pressure Pump. If pressure is below 10 psi after **5 minutes** of operation, replace Pre-Filter element.

6.1 Operator Maintenance Intervals

The frequency of required maintenance is dependent on the regularity of usage, the condition of the intake water (the location of use), the length of time the system is exposed to water, the total running time and, in some cases, the manner in which the system is installed or operated. Because of these factors, it is virtually impossible to comprise an exact timetable for required maintenance. The following maintenance timetable is an estimate of the time intervals at which maintenance may be required on the various systems components. This is based upon factual data compiled from HRO Systems installations around the world. However, this schedule must be adjusted to each individual system depending upon the variables listed.

COMPONENT	MAINTENANCE REQUIRED	TIME INTERVAL CONTINUOUS	TIME INTERVAL INTERMITTENT DUTY
Sea Strainer	Inspect & Clean Screen & Housing	weekly	100 hours
Plankton Filter	Inspect & clean	weekly	100 hours
Pre-filter	Replace element	Low Pressure <6 psi	Low Pressure <6 psi
Flow Meter	Clean Inside of the clear tube	As required when dirty	
High Pressure Pump	Change oil	First 50 Hours New Pump Break In Period	Annually
	Replace Seal Kit	2000 hrs. / as required	2000 hrs.
	Replace Valve Kit	2000 hrs. / as required	2000 hrs.
R. O. Membrane	Clean Element	When production or salt rejection decreases by 10%	
Salinity Probe	Clean Probes	Annually	Annually
Charcoal Filter	Replace Element	3 months	3 months
U.V. Sterilizer	Replace lamp & clean quartz sleeve	2000 Hours	2000 Hours
Fresh Water Flush Charcoal Briquette	Replace Element	3 months	3 months
Other	_____		
Other	_____		
Other	_____		
Other	_____		
Other	_____		

6.2 Individual Component Maintenance & Repair

1. **Inlet Thru Hull Fitting [1]:** Non Horizon Reverse Osmosis component. Keep the Inlet Thru Hull Fitting free and clear of debris and marine growth. If the Inlet Thru Hull Fitting is clogged, this results in a low feed pressure condition, which causes the system to shut off.
2. **Inlet Sea Cock Valve [2]:** Non Horizon Reverse Osmosis component. The packings and connections of the Inlet Sea Cock Valve must be tight and must properly seal. Clean the valve cavity of debris or replace the seal and seat, or the entire valve, as required. This section is under a vacuum condition while operating the system. Loose fittings or worn seal will allow air to enter the Horizon Reverse Osmosis system causing continual shut down due to subsequent low feed water pressure.
3. **Sea Strainer [3]:** Keep the mesh screen free and clear of debris. When the mesh screen is clogged, it results in a low-pressure condition causing system shut off. This section is under a vacuum condition while operating the system. If the Sea Strainer's bowl is loose or if the O-ring seal is worn or not properly seated, air will enter the system causing continual shut down due to subsequent low feed water pressure.

To clean the Sea Strainer:

- a. Remove the bowl by turning it counter-clockwise.
- b. Remove the Mesh Screen from the bowl.
- c. Remove the flat sealing gasket carefully from the bowl. The gaskets are fragile, so handle with care.
- d. Wipe the sealing gasket with a damp cloth. Lubricate it sparingly with Parker "O" ring lubricant.
- e. Place the seal back onto the bowl. Seat the mesh screen back into the bowl.
- f. Screw the lid on clockwise. *Hand-tighten only enough to seal water in and air out.*

4. Booster Pump[4]:

Seafari 170 Booster Pump with Electric Motor: This booster pump is not economically repairable. Replace the pump if it fails to deliver the proper flow or pressure to the system. Do not replace this pump with an intermittent duty pump found in marine stores. Use of a different pump may cause motor over heating, damage to the Control Box components, insufficient feed water pressure, or continual shut down of the Seafari 170. The HRO Seafari 170 Booster Pump is specifically manufactured for Horizon Reverse Osmosis for use as a continuous duty Feed Water Booster Pump for the Seafari 170 and available only through an authorized Horizon Reverse Osmosis Service Dealer or directly through Horizon Reverse Osmosis.

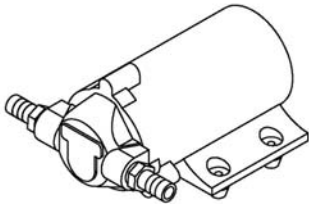

Seafari 350 Booster Pump with 1/3 Horse Power Electric Motor:

Disassembly

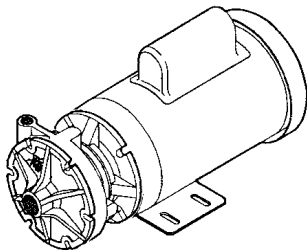

1. Disconnect Power Source to motor.
2. Disconnect electrical connections tagging wires carefully to preserve correct rotation.
3. Remove pump and motor assembly to repair area.
4. Remove bolts and volute cover from pump.
5. Remove impeller locknut and impeller. Unscrew CCW.

6. Remove seal head from the shaft. Slide from the shaft.
7. Remove four motor bolts and remove volute bracket from motor.
8. Remove seal seat from bracket.

Reassembly

1. Clean seat cavity of the volute bracket thoroughly.
 2. Thoroughly clean pump shaft. Assure that the shaft is not grooved and that there is no evidence of pitting or fretting. If the shaft is grooved, fretted, or worn, replace it.
 3. Install the pump shaft onto the motor shaft. Ensure all debris and burrs are removed from the motor shaft.
 4. Place the volute bracket on a firm surface with the seat cavity (pump end) up. Then place a small amount of vegetable oil on the seat cup or o-ring seat. Place the seat in the seat cavity with the polished face up toward the pump end. Evenly push seat into cavity with fingers then gently tap seat into place with a wooden dowel or plastic rod (1 - 1/8" outside diameter / 28 mm). To help ensure the seat is not damaged place the cardboard disk supplied with the seal over the seat face.
 5. Place volute bracket on motor (aligning the base if applicable). Secure volute bracket with four motor bolts.
 6. Pull pump shaft forward until shoulder of pump shaft contacts back of volute bracket and slightly snug one setscrew to hold shaft in place.
 7. Install seal head assembly
 - a. Lubricate shaft and elastomer with vegetable oil.
 - b. Install rotary seal head onto pump shaft and slide toward seat until carbon face touches seal seat.
 - c. Install seal spring and retainer.
 - d. Thread impeller onto pump shaft ensuring that the spring retainer does not slip between the shoulder of the shaft and the hub of the impeller. Install locknut with small amount of removable loctite. Hold shaft with locking type pliers (vice grips) and tighten impeller locknut.
 - e. Loosen pump shaft setscrew.
 - f. Install new volute cover gasket and mount volute cover. Secure with bolts and tighten evenly.
 - g. Slide pump shaft forward until impeller touches volute cover. Slide shaft back with a screwdriver .010 - .015" (0.254 - 0.381 mm). Tighten pump shaft setscrews. Rotate shaft by hand to ensure impeller does not rub against volute cover.
 8. Return pump to installation and reconnect electrical connections.
 9. Start pump momentarily to observe shaft rotation. If rotation corresponds to the rotation arrow, pump may be put into service. If rotation is incorrect, refer to the wiring diagrams within this manual.
- 5. Plankton Filter [5] Element Cleaning:** Identical procedure for Pre-filter and Charcoal Elements
1. Unscrew the bowl counter clockwise.
 2. Remove the Plankton Filter Element from the bowl.
 3. Remove the O-Ring from the top of the bowl. The O-Ring is fragile, so handle it with care.
 4. Clean the mesh screen filter element with a bristle brush and water spray.

5. Wipe the O-Ring with a damp cloth.
6. Lubricate the O-Ring lightly using a sparingly amount of O-Ring lubricant.
7. Place the O-Ring back onto the bowl.
8. Insert the cleaned, or a new plankton filter element into the bowl.
9. Screw the bowl on clockwise.
10. Hand snug to seal the O-Ring; do not use a wrench or other tool to tighten; do not over tighten. Over tightening may damage the threads in the bowl or housing and cause removal to be difficult.

- 6. Pre-filter [6] Element Replacement:** The Prefilter Pleated Cartridge Element may be cleaned with water spray once or twice. After cleaning the expected life will be reduced in half. Attempts to clean the element more than twice will result in a very short life and will damage the element rendering it useless. Change the element after the first or second cleaning. Clean or replace the element when plugged to the extent that the Low Pressure Gauge at the control panel reads 10 to 6 psi. At slightly below 6 PSI, the Low Pressure Switch shuts the system off.

CAUTION: Do not use third party prefilter elements; use only Horizon Reverse Osmosis Prefilter Elements. Third party prefilter elements on the market do not properly fit, the seams fall apart, they will allow by-pass, and will allow the R.O. Membrane Element to foul prematurely. Use of third party prefilter elements will void any and all Horizon Reverse Osmosis warranty to the High Pressure Pump and the R.O. Membrane Element.

IMPORTANT: Do not use "string wound" or "fiber" prefilter elements. These types of elements are designed for the Photographic Film Developing industry. When used in seawater, they will plug up rapidly in 1/10th or less the time causing frequent shut down of the system and very frequent changing which will also lead to very high cost of maintenance. Use of String Wound or Fiber type elements will only lead to user frustration and very high maintenance costs. Use of third party prefilter elements will void any and all Horizon Reverse Osmosis warranty to the High Pressure Pump and the R.O. Membrane Element.

To clean or replace the Prefilter Element:

1. Unscrew the bowl counter clockwise.
 2. Remove the Prefilter Pleated Cartridge Element from the bowl.
 3. Remove the O-Ring from the top of the bowl. The O-Ring is fragile, so handle it with care.
 4. Replace the Prefilter Pleated Cartridge Element with a new Horizon Reverse Osmosis element.
 5. Wipe the O-Ring with a damp cloth.
 6. Lubricate the O-Ring lightly using a sparingly amount of O-Ring lubricant.
 7. Place the O-Ring back onto the bowl.
 8. Insert the cleaned or new Horizon Reverse Osmosis Prefilter Pleated Cartridge Element into the bowl.
 9. Screw the bowl on clockwise.
 10. Hand snug to seal the O-Ring; do not use a wrench or other tool to tighten; do not over tighten. Over tightening may damage the threads in the bowl or housing and cause removal to be difficult.
- 7. Low Pressure Gauge [7]:** If the pressure gauge fails to register, the orifice may be corroded with debris. Use a thin wire or small diameter (1/64th" / 0.4 mm) drill bit to dislodge any debris trapped within the pressure port orifice. If clearing the orifice does not bring the gauge to normal operation then replace the gauge.

- 8. Low Pressure Switch [8]:** The Low Pressure Switch contains one N.O. (Normally Open) contact. As the Booster Pump builds pressure on the Pre-filtration Section, the Low Pressure Switch closes at 6 PSI (+- 2 psi). When pressure decreases below 6 PSI (+/- 2 PSI), the Low Pressure Switch opens and shuts the system off. Adjustment of the Low Pressure Switch is not recommended.

If in field adjustment is absolutely necessary:

1. Stop the Seafari system.
2. Remove the cap located in the center top of the pressure switch to expose the calibration screw.
3. Adjust the calibration screw, maximum 1/8th turn (45 degrees) at a time, clockwise to increase and counter clockwise to decrease the set point.
4. Restart the system and check the setting by slowly closing the Inlet Sea cock Valve while observing the Low Pressure Gauge at the point of shut down.
5. Repeat as necessary to calibrate the switch.
6. Replace the Switch if calibration is not successful.

9. Future Reference.[9]:

- 10. High Pressure Pump Electric Motor:** Troubleshoot electric motor failure to ensure that any abnormality from the power, wiring, wiring connections, contactor, or control circuit are not at fault or at cause. If the electric motor has failed, it will require replacement. Depending upon failure, replacement may be more cost effective than repair. If failure of the motor is due to external source and not the motor itself, then correct the cause or else the replacement or repaired motor will fail again.

Failures of the electric motor may be:

- Bearing failure. Bearings are field replaceable.
- Winding failure. Generally caused by low or high power, below or above the specified voltage requirements of the system, feeding the motor. Not economically repairable.
- Internal centrifugal switch. Generally mechanical failure of the switch. Field replaceable.
- Capacitor failure. Generally caused by low power feeding the motor. Also caused by rapidly repeating starting and stopping of the motor. Field replaceable.

11. High Pressure Pump.[11]:

Failure Signs and possible causes (troubleshooting):

1. Abnormally High Pulsations at the High Pressure Gauge are caused by.
 - Worn or broken Valve
 - Worn or broken Valve Spring
 - Worn or broken Valve Seat
 - Debris in Valve Chamber
2. Water Leak between the High Pressure Pump Manifold and Rear Section caused by.
 - Worn Low Pressure Seals
 - Low Pressure Seals damaged due to running dry.
3. Flow drops dramatically when attempting to pressurize and or unable to build pressure. This is caused by:
 - Worn High Pressure Seals
 - High Pressure Seals damaged due to running dry
 - Broken Valve
 - Broken Valve Spring
 - Debris in Valve Chamber

12. High Pressure Pump Servicing

a. Disassembly of the Discharge Valve Assemblies:

Tools required: 3/8" Drive Ratchet; 6 mm Hex Socket; O-Ring Pick; Two slotted screwdrivers, Torque Wrench; Needle Noise Pliers.

- 1) Only one valve kit is required to repair all of the valves in one pump. The Valve Kit includes new valve O-Rings, valve seats, valves, and springs.
- 2) Disconnect all plumbing.
- 3) Remove the six socket head screws from the manifold. Remove the outer screws first, then the inner screws.
- 4) Using a soft mallet, tap the backside of the Discharge Manifold from alternate sides to maintain alignment and avoid damage to the plungers.
- 5) Grasp the Discharge Manifold from the underside and gradually lift manifold while you pull away from the Crankcase.
- 6) The Adapter/Spacers may stay with either the Discharge or Inlet Manifold. By inserting two opposing screwdrivers between Spacer and manifold, you can easily remove them from the Discharge Manifold. If they stay in the Inlet Manifold, gently work them up and down as you pull away from the Inlet Manifold.
- 7) The Valve Assemblies are in the Discharge Manifold ports and will fall out when manifold is turned over.

b. Disassembly of the Seal Assembly:

Tools Required: 3/8" Drive Ratchet; 6mm Hex Socket; Packing Extractor; and Colette.

- 1) Remove the Inlet Valve Assembly from the exposed plunger rod ends, including Cotter pin, Nut, Washer, Spring, Spacer, and Inlet Valve.
- 2) Grasp the Inlet Manifold from the front and underside and pull to remove from Plunger Rods.
- 3) Carefully examine backside of Low Pressure Seal before removing from manifold as it will be damaged during removal. If worn, insert screwdriver into I.D. of seal and pry out. Exercise caution to avoid damage to the Inlet Manifold.
- 4) Press ceramic Plunger with thumb or soft tool from backside of Inlet Manifold. (The High Pressure Seal may stay with the plungers or remain in the Inlet Manifold. If on the plungers, slide off by hand. If in the manifold, use reverse pliers to remove.)
- 5) Remove Seal Retainers from Crankcase by grasping tab with pliers and pulling out.
- 6) Examine Crankcase Oil Seal to determine if Crankcase servicing is needed.
- 7) Examine Ceramic Plunger, Low Pressure Seals, V-Packings for scoring, cracks, and wear and replace if necessary.

c. Reassembly of Seal Assembly:

- 1) Examine Seal Retainers and replace if worn or damaged. Install on Plunger Rod and press into Crankcase **with tab out**.
- 2) Place Inlet Manifold on work surface with **Crankcase Side up**.
- 3) Lubricate new Low Pressure Seals and press into position with **garter spring down**. Be certain the seal is seated squarely on the shoulder on the inlet manifold chamber.
- 4) Place the inlet Manifold on work surface with **Crankcase side down** (Larger ID ports up).
- 5) Carefully examine the Plungers for scoring or cracks and replace if worn.

- 6) Lubricate Ceramic Plungers and new High Pressure Seals. Press the plunger into the seal and position seal in middle of plunger. **NOTE:** Place the deeper recessed end of the plunger into the seal from the metal backside.
- 7) Insert the Plungers into the manifold ports. Press into position using the **larger I.D. end of Discharge Valve Spacer**. Examine the O-Ring and Back-up-ring under the Sleeve for cuts or wear and replace. Examine the Barrier Slinger for wear and replace as needed. Install the Barrier Slinger with the concave side facing away from the Crankcase. Lubricate the Plunger Rod O-Ring to avoid cutting during installation. Install the Back-up-ring first then the O-Ring into the groove on the Plunger Rod. Install the Sleeve with the tapered end facing out. Gently press towards the Plunger Rod shoulder until flush with the Barrier Slinger.
- 8) Carefully install Inlet Manifold over Plunger Rod ends and slowly press into Crankcase.
- 9) Examine Inlet Valve and replace if worn. **Inlet valves cannot be reversed if worn.** The SS Inlet Valves may be lapped if not badly worn. Install the SS Inlet Valves with **square edges towards the plungers** (round edges towards the discharge). Install the Nylon Inlet Valve with **ridged side towards the discharge**.
- 10) Examine Spacers for wear and replace as needed. Install Spacer on each Plunger Rod with **smaller O.D. towards inlet valve**.
- 11) Examine Springs for damage or fatigue and replace as needed. Place on Plunger Rods.
- 12) Install Washers next with **concave side towards Inlet Manifold**.
- 13) Install Nuts and torque to 55 in. lbs. / 4 ft. lbs. / 4 Nm.
- 14) **Always install new Cotter pins** and turn ends to secure in position.

f. Reassembly of the Discharge Valve Assembly:

- 1) Examine Adapter Spacer O-Rings and replace if worn. Lubricate and install O-Rings and Back-up-Rings on **both front and rear of the Adapter Spacer**.
- 2) **Examine the Valve Retainers for scale build up or war and install into each Discharge Manifold port with tab down into the manifold chamber.**
- 3) **Replace worn or damaged springs and place into Retainers.**
- 4) **Examine Valve and Seats for pitting, grooves, or wear and replace as needed.**
- 5) **Place Valves over springs with concave side down.**
- 6) **Place Valve Seats on Valves with concave side down.**
- 7) **Lubricate O.D. of Adapter/Spacer and insert smaller I.D. into Discharge Manifold ports. Snap into position. Exercise caution not to cut or pinch O-Rings.**
- 8) **Carefully guide Discharge Manifold with Spacers over Plunger Rod ends and press into Inlet Manifold.**
- 9) **Replace Socket Head Screws and torque to 115 in. lbs. / 9.4 ft. lbs. / 13 Nm**
- 10) **If oil was not changed, be sure oil is at the proper level on the sight gauge.**

Torque sequence for tightening the manifold:

3	1	5
X	X	X
X	X	X
6	2	4

13. Reverse Osmosis Membrane Element Replacement:

NOTES:

- The Seafari Membrane Element is accessible with the Vessel still attached to the frame.
- Replace all Brine and Product Water O-Rings attached to the End Plugs within the High Pressure Vessel Assembly each time the Reverse Osmosis Membrane Element is removed or replaced. Ensure these O-Rings are on hand prior to repair.
- Membranes are only installed and removed from the INLET end of the High Pressure Vessel.

Tools Required:

5/16" Allen wrench
regular pliers
Needle-Nose Pliers

1. Disconnect the High Pressure Hose from each end of the High Pressure Vessel Assembly.
2. Using a 5/16" Allen wrench remove the 3 each Socket Head Cap Screws from the three-piece Segment Rings located at each end of the Pressure Vessel.
3. Push inward on the End Plug and Remove the three-piece segment ring from one end, repeat for the other end.
4. Remove the Port Retainer from each end.
5. Remove the High Pressure Port from each end.
6. Remove the product water tube from the respective end.
7. Insert all three of the Socket Head Cap Screws back into the End Plug. These screws are used as a grip to remove the End Plug.
8. Grasp one or more of the Socket Head Cap Screws with a pair of pliers and pull slowly outward to remove the End Plug. There is some resistance due to the two Brine O-Rings exerting friction against the Vessel wall. With the End Plug removed from the High Pressure Vessel, the Reverse Osmosis Membrane Element is visible.
10. Remove and discard the brine O-rings from each of the End Plugs.
11. Remove and discard the Product Water O-rings from each of the End Plugs.
12. Clean the end plugs with a cloth and inspect each for any sign of wear, cracks, or damage.
13. Sparingly, lightly, lubricate:
4 (four) NEW Brine O-Rings and 4 (four) new Product Water O-Rings for the Seafari 170
or
4 (four) NEW Brine O-Rings and 2 (two) new Product Water O-Rings for the Seafari 350
14. Place the NEW Product Water O-Rings into the product port inner O-Ring groove in each of the End Plugs.
15. Place the NEW Brine O-Rings onto the outer Brine O-Ring grooves of each of the End Plugs.
16. **CAUTION:** At each end of the Reverse Osmosis Membrane Element is a Product Water Tube approximately 3/4" diameter by 1" long. The outside diameter surface of this product water tube is a sealing surface, which isolates the Product Water from the Feed Water. The surface of the Product Water Tube must be scratch free. Never use pliers or other grabbing tools on the Product Water Tube. Do not drop the R.O. Membrane onto a hard surface as the Product Water Tube may be damaged.

With your fingers, grasp the Product Water Tube attached to the R.O. Membrane Element from the INLET end of the Pressure Vessel and pull outward. If resistance is met, then cup the INLET end of the High Pressure Vessel with one hand and shake downward to dislodge the R.O. Membrane Element.

17. Run a rag through the High Pressure Vessel to remove any biological film or debris from the High Pressure Vessel.
18. A new Horizon Reverse Osmosis R.O. Membrane Element comes complete with a "U" cup Brine Seal at one end of the Element. **This Brine Seal must be positioned at the INLET end of the Pressure Vessel.**

INLET End	OUTLET End
Feed Water Entry End	Brine Discharge End
R.O. Membrane Element Brine Seal End	no brine seal on this end

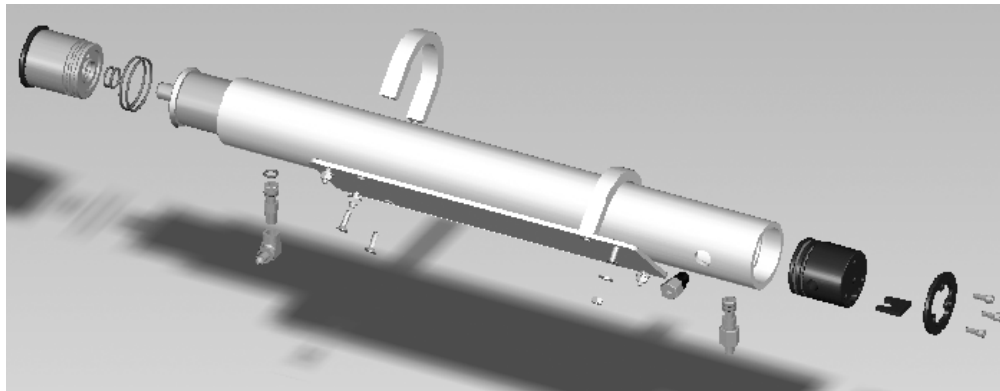

Install a new R.O. Membrane Element with attached "U" cup Brine Seal into the Pressure Vessel. Place the end of the R.O. Membrane Element that DOES NOT have the Brine Seal attached into the INLET end of the Pressure Vessel and slide it into the Pressure Vessel. (Insert the down stream end [end without a brine seal] of the Reverse Osmosis Membrane Element into the upstream inlet end of the High Pressure Vessel.)

**Inlet end of Pressure Vessel
Brine Seal End of R.O. Membrane Element**

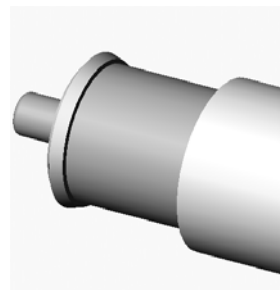

19. Slide the Membrane Element into the High Pressure Vessel, past the brine seal, until the Membrane Element product water tube is 4 inches past the end lip of the High Pressure Vessel.
20. Insert the End Plug with new attached O-Rings into the High Pressure Vessel while aligning the High Pressure Port and Product Water Port to the respective holes in the High Pressure Vessel. Continue pushing inward on the End Plug until its exposed end travels just past the Segment Ring Groove in the Pressure Vessel. Ensure that the Ports of the End Plug are aligned with the Port Holes of the High Pressure Vessel.
21. Insert the High Pressure Port Fitting with attached O-Rings into the High Pressure Port.
22. Replace the Port Retainer.
23. Insert the three-piece Segment Ring Set into the Segment Ring Groove of the High Pressure Vessel. Align the Segment Ring Set with the tapped holes in the End Plug for insertion of the three Socket Head Cap Screws. Attach the three Socket Head Cap Screws and tighten.
24. Connect the High Pressure Hoses to the respective fitting on the Pressure Vessel.

- 14. High Pressure Gauge [15]:** If the pressure gauge fails to register the orifice may be corroded with debris. Use a thin wire or small diameter (1/64th" / 0.4 mm) drill bit to dislodge any debris trapped within the pressure port orifice. If clearing the orifice does not bring the gauge to normal operation, then replace the gauge.
- 15. High Pressure Switch [16]:** The High Pressure switch keeps the system in operation when the operating pressure is below 950 PSI (± 50 psi). If the operating pressure reaches 950 PSI (± 50 psi), the High Pressure Switch shuts the system off. In field, adjustment of the High Pressure Switch is not recommended. If adjustment is absolutely necessary,
- Open fully the Back Pressure Regulator [17].
 - Start the Seafari system.
 - Remove the sealing cap located on the top of the pressure switch to expose the calibration screw.
 - Using a 3/16" hex wrench, gently adjust the calibration screw, maximum 1/8th turn (45 degrees) at a time. Turn the screw clockwise to increase the trip point and counter clockwise to decrease the trip point as appropriate.
 - Slowly increase operating pressure while observing the High Pressure Gauge. The High Pressure Switch should stop the system at 950 PSI (± 50 PSI). If the system shuts off below 900 PSI or above 1000 PSI, then repeat the adjustment procedure and retest the set point.
 - Once the High Pressure Switch is properly set, replace the adjustment screw cover.
- 16. Back Pressure Regulator [17]:** If the Back Pressure Regulator valve leaks from the valve stem, lightly tighten the packing gland nut located below the valve stem. Should adjustment fail to stop the leak replace the stem and internal packing or replace the entire valve.
- 17. Brine Discharge Thru Hull Fitting [1]:** Non Horizon Reverse Osmosis component. Keep the Brine Discharge Thru Hull Fitting free and clear of debris and corrosion.
- 18. Salinity Probe [19]:** The salinity probe requires cleaning once a year.
- Unscrew the black tube fitting nut below the probe to disconnect it from the control manifold.
 - Using a soft bristle brush, scrub the probes to remove any built up debris. Thoroughly dry the probe area.
- Salinity Probe Calibration:
- After steps a. and b. with the Salinity Probe exposed to air, place one finger over the open port of the Salinity Probe Tee connector to ensure that no Brine Discharge water expels from the hole. Press the "Start" switch. Wait for approximately 10 seconds.
 - If the Salinity Probe is exposed in the air and it is dry, the "Water Quality" LED should illuminate green. At this point only product water may expel from the Salinity Probe Tee connector hole.
 - If the LED does not illuminate green, disconnect probe cable from the circuit board terminals. If the LED illuminates green after disconnecting the probe cables, then replace the Salinity Probe with a new one.
 - Dip the Salinity Probe electrodes well into test solution of 1,000 PPM TDS.
 - Gently rotate the "SALINITY SET" control adjustment pot on the main circuit board fully clockwise, then slowly rotate it back counter clockwise until the "Water Quality" LED illuminates red. Do not over turn. Note that there is a 5 second delay for the LED to change from red to green, no delays from green to red.
 - This completes the Salinity Probe calibration.
 - Reconnect Salinity Probe Cables.
 - Reconnect Salinity Probe to its Tee Connector.

19. **Flow Meter [20]:** Since the flow meter body is clear, light penetrates it and supports biological growth. To clean the flow meter body, remove the top access fitting, the guide rod, float and O-Ring bumpers, and tube stops. Clean the interior of the tube using a bottlebrush, soft rag, cotton swab or other soft item. Reassemble the unit.

20. 3-way Product Water Diversion Solenoid Valve [21]:

- a. Over tightening of the tube fittings into the valve's body can cause the Diversion Valve internal ports to move out of proper position resulting in internal blockage or bypassing.
 - 1) Remove Diversion Valve from the system and adjust ports.
 - 2) Position the manual over ride button OUTWARD to normal position by first pushing the button inward and rotating it counter clockwise allowing it to spring outward away from the coil body.
 - 3) With your mouth, blow into port "P", air should expel from port "B" which is the "normally open" or "bad water" port.
 - 4) If it is extremely difficult to expel air from port "B" or if no air expels from port "B", then port "B" requires adjustment.
 - 5) Again blow into port "P" while plugging port "B" with a finger tip. No air should expel from port "A".
 - 6) If air expels from port "A", then port "A" requires adjustment.
 - 7) Position the manual over ride button INWARD to manual over ride position by pushing the button inward and rotating it clockwise allowing it to lock inward close to the coil body.
 - 8) With your mouth, blow into port "P", air should expel from port "A" which is the "normally closed" or "good water" port.
 - 9) If it is extremely difficult to expel air from port "A" or if no air expels from port "A", then port "A" requires adjustment.
 - 10) Again blow into port "P" while plugging port "A" with a fingertip. No air should expel from port "B".
 - 11) If air expels from port "B", then port "B" requires adjustment.

b. Solenoid Valve Coil Check:

- 1) The 3-way Product Diversion Valve Solenoid operates from 12 VDC. To check the condition of the Diversion Valve solenoid coil,
 - a) While system is operating and while the "safe water" lamp on the Touch Pad is illuminated green, remove the din connector from the valve's coil. Using a voltmeter set to DC, check the voltage at the din connector terminals.
 - b) If 12 VDC is present at the din connector terminals, then the control circuit is operating normally, but the 3-way Diversion Valve Coil may be defective. Check the solenoid coil continuity.
 - c) Using an Ohm meter, measure the continuity of the solenoid coil as shown below.

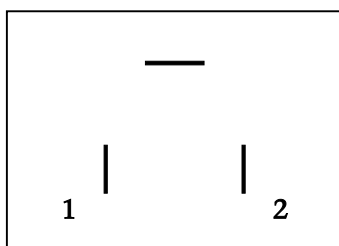

Measure the DC resistance between pins 1 & 2. Proper resistance reading is approx. 12 to 15 Ω.

- d) If an open circuit exists, or if the resistance is much greater than or less than 12 to 15 Ω , then replace the solenoid coil or the entire valve.
- e) If 12 VDC is not present at the din connector terminals, then the cable connections may be loose, the cable may be broken, or the control circuit may be defective. Check these components.
- f) Check for 12 VDC at the connection points of the Diversion Valve Solenoid Coil on the Control Printed Circuit Board terminals.
- g) If 12 VDC is present while system is operating and while the "safe water" lamp on the Touch Pad is illuminated green, then the Diversion Valve cable is loose at one of the connections or the cable is defective.
- h) If there is no voltage present while system is operating and while the "safe water" lamp on the Touch Pad is illuminated green, then troubleshoot the Control Printed Circuit Board.

21. Charcoal Filter [22]: A sulfurous (rotten egg) odor from the product water requires the replacement of the Charcoal Element. Otherwise, the Charcoal Element should be replaced every 3 to 4 months. It is not cleanable.

To replace the Charcoal Filter Element:

1. Unscrew the bowl counter clockwise.
2. Remove the Charcoal Filter Element from the bowl.
3. Remove the O-Ring from the top of the bowl carefully.
4. Replace the Charcoal Filter Element with a new Horizon Reverse Osmosis element.
5. Wipe the O-Ring with a damp cloth.
6. Lubricate the O-Ring lightly using a sparingly amount of O-Ring lubricant.
7. Place the O-Ring back onto the bowl.
8. Insert the new, Horizon Reverse Osmosis Charcoal Filter Element into the bowl.
9. Screw the bowl on clockwise.
10. Hand snug to seal the O-Ring, do not use a wrench or other tool to tighten, and do not over tighten. Over tightening may damage the threads in the bowl or housing, and over tightening will cause removal to be difficult.

22. Ultraviolet Sterilizer [23]: The UV Sterilizer lamp emits a low frequency form of light. This light degrades and loses intensity and ability to sterilize biological matter over approximately 2,000 hours of use. Therefore, the lamp may remain lit, but requires replacement every 2000-4000 hrs.

CAUTION: Make sure that system power is turned off before beginning sterilizer maintenance. Ultra Violet light is harmful to eyes and skin.

Lamp Replacement:

- a. Remove the top lid. The ballast should remain in the lid.
- b. Remove the lamp and the lamp plug from the quartz sleeve.

- c. Replace the lamp. During lamp replacement clean the quartz sleeve as well. The quartz sleeve should be crystal clear and if it has discolored, it must be cleaned or replaced.

Quartz Sleeve Cleaning:

- a. Remove the top cap (cap, ballast, and lamp).
- b. Remove the three Phillips-head screws on the top end bushing.
- c. Remove the top bushing and the top O-Ring and place in a safe place.
- d. Remove the three Phillips-head screws on the bottom bushing. Do not remove the center screw). When you lower the bottom bushing, the quartz sleeve should slide with it.
- e. Remove the bottom O-Ring and clean it with a damp cloth.
- f. Clean the quartz tube with water and a bottlebrush. Dry with a soft cloth. Handle the quartz sleeve carefully.

Reassembly:

- a. Insert the quartz tube into the Bottom End Plug and seat it into the center O-Ring.
- b. Attach a new U.V. Lamp into the plug.
- c. Slide the lamp into the Quartz Tube and seat the top end plug into the vessel.
- d. Replace the three 1/4-20 cap head screws.

23. Fresh Water Flush [25 & 26]: The Charcoal Element in the Fresh Water Flush should be replaced every 3 months.

The Fresh Water Flush will automatically flush the system with Fresh Water every 7 days. The duration of the flush can be adjusted to last from 5 to 27 minutes.

Fresh Water Flush Duration Adjustment:

- a. Open the Electrical Control Box to expose the Control Printed Circuit Board.
- b. Apply Supply Power from the Power Source to the system.
- c. Using a voltmeter set to DC Volts measure the D.C. Voltage across the Fresh Water Flush Duration Voltage pins located on the Control Printed Circuit Board.
- d. While measuring the D.C. Voltage across the Fresh Water Flush Duration Voltage pins, adjust the Fresh Water Flush Duration pot to correspond the voltage to the time duration in the table below. (For example, if you want the Fresh Water Flush duration to be 13 minutes, then adjust the pot to give 2.0 VDC across the pins.):

Duration of Fresh Water Flush Minutes:	5	7	10	13	17	20	24	27
Corresponding D.C. Voltage Measured:	0.75	1.0	1.5	2.0	2.5	3.0	3.5	4.0

- e. Press the Reset Switch on the Control Printed Circuit Board.
- f. Reassemble the Controller Enclosure.

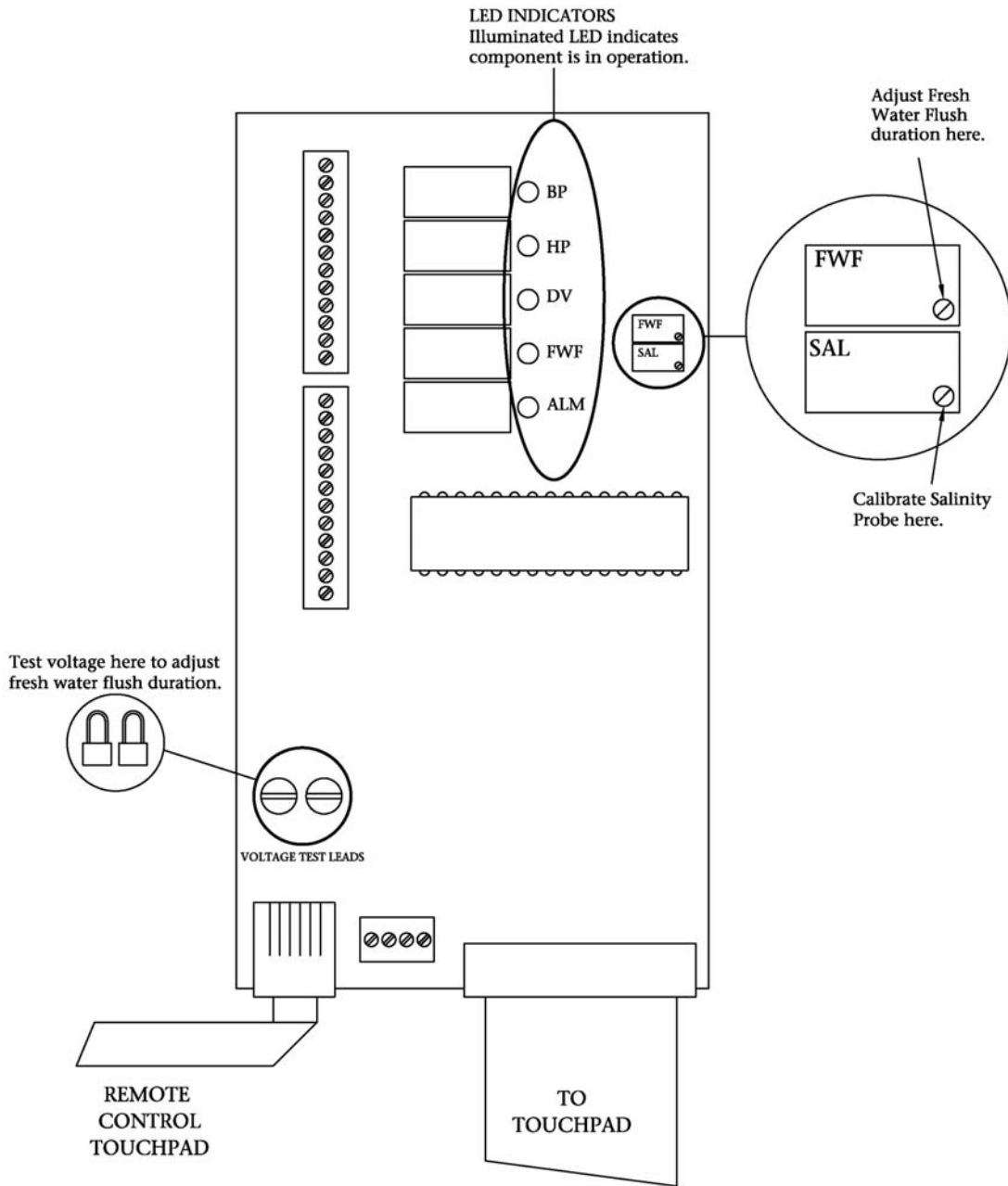

Section 7

Electrical Information

Electrical Requirements

Electrical Specifications

Electrical Wire Sizes

Electrical Diagrams

ELECTRICAL REQUIREMENTS & INFORMATION:

- 1. Amperage Notes:** The Electric Motors within the Seafari 170 & 350 systems start in series with time delay between each motor starting after the Touch Pad “Start” Switch is pressed. First, the Booster Pump starts, then the main High Pressure Pump Electric Motor starts. Alternatively, the Booster Pump may be started manually by pressing the “Booster Pump” Switch.

During start up, the current of the Booster Pump Electric Motor surges to “Locked Rotor” amperage for a fraction of a second after which the current drops to normal running load. Then the High Pressure Pump Electric Motor starts and surges to “locked Rotor” amperage for a fraction of a second after which the current drops to normal running load.

Therefore, the maximum surge current equals the Booster Pump Electric Motor normal running amperage plus the High Pressure Pump Electric Motor starting amperage. Normal operational amperage equals the normal operating amperage of the Booster Pump Electric Motor plus the normal operating amperage of the High Pressure Pump Electric Motor.

- 2. POWER SOURCE REQUIREMENTS:** Check line voltage and frequency to ensure that it agrees with system nameplate. Grounding and circuit protection should be done in accordance with National Electrical Code. See connection diagram on nameplate of motor or refer to the diagrams within this manual.

Voltage	HZ (AC)	Min. HZ	Max. HZ	Min. Voltage	Max. Voltage
DC Systems					
12 VDC	N/A	N/A	N/A	11 VDC	15 VDC
24 VDC	N/A	N/A	N/A	22 VDC	30 VDC
AC Systems					
120 VAC	60 HZ	58 Hz	62 Hz	108 VAC	132 VAC
230 VAC	60 HZ	58 Hz	62 Hz	207 VAC	253 VAC
100 VAC	50 HZ	48 Hz	52 Hz	90 VAC	110 VAC
220 VAC	50 HZ	48 Hz	52 Hz	198 VAC	242 VAC

- 3. MOTOR ROTATION:**

Refer to Booster Pump and High Pressure Pump markings to determine proper rotation.

A.C. Systems: Refer to Booster Pump Electric Motor nameplate and High Pressure Pump Electric Motor nameplate for wiring connections and rotation notations.

DC Systems: The High Pressure Pump DC Electric Motor and Booster Pump DC Electric Motor rotation are polarity sensitive. If rotation is incorrect, check incoming polarity and individual motor wiring. Jog the motor by pressing the Start Switch and then quickly thereafter pressing the Stop switch.

4. ELECTRICAL MOTOR POWER SPECIFICATIONS:

(H.P. = Horse Power; FLA = Full Load Amperes; LRA = Locked Rotor Amperes @ Start Up)

ALTERNATING CURRENT SYSTEMS:

Seafari 170:

High Pressure Pump Motor

VAC	H.P	FLA	LRA
110 - 115	1/3	6	26
220 - 230	1/3	3	13

Booster Pump Motor

VAC	H.P	FLA	LRA
110 - 115	1/8	1	20.2
220 - 230	1/8	.5	10

Seafari 350

High Pressure Pump Motor

VAC	H.P	FLA	LRA
110 - 115	1	13	52
220 - 230	1	6.5	26

Booster Pump Motor

VAC	H.P	FLA	LRA
110 - 115	1/3	6	24
220 - 230	1/3	3	12

DIRECT CURRENT SYSTEMS:

Seafari 170 only (HRO SF 350 is not available in Direct Current [DC])

High Pressure Motor

VDC	H.P.	FLA
12	1/3	29
24	1/3	14

Booster Pump Motor

VDC	H.P.	FLA
12	1/8	5
24	1/8	2.5

5. RECOMMENDED CIRCUIT BREAKER AMPERAGE RATING:

Seafari 170

Operating Voltage	Recommended Circuit Breaker
12 VDC	40 Ampere
24 VDC	20 Ampere
115 VAC	10 Ampere
230 VAC	10 Ampere

Seafari 350

Operating Voltage	Recommended Circuit Breaker
N/A	
N/A	
115 VAC	25 - 30 Ampere
230 VAC	15 Ampere

6. RECOMMENDED WIRE SIZES:

CAUTION: DO NOT USE ROMEX TYPE SOLID CORE WIRE. SOLID CORE WIRE CAN EASILY BREAK AND WILL NOT FIT OR SEAL INTO THE SUPPLIED STRAIN RELIEFS. USE ROUND JACKETED STRANDED WIRE PREFERABLY WITH AN OUTER JACKET DESIGNATION OF SJO OR SIMILAR COMPATIBLE WITH MARINE USE AND AN OILY ENVIRONMENT. FOR DC OPERATION, FINE STRAND WIRE, SIMILAR TO BATTERY CABLE, IS PREFERRED FOR MINIMAL RESISTANCE AND MINIMAL VOLTAGE DROP.

RECOMMENDED POWER WIRE SIZE TO SYSTEM:

Seafari 170

Operating Voltage	Maximum Load	Recommended Minimum Wire Size Length of run		
	Amperage	10 Ft / 3 meter	20 Ft / 6 meter	30 Ft / 9 meter
12 VDC	34 Ampere	6 AWG / 13 mm ²	4 AWG / 19 mm ²	4 AWG / 19 mm ²
24 VDC	16.5 Ampere	8 AWG / 8 mm ²	6 AWG / 13 mm ²	6 AWG / 13 mm ²
115 VAC	7 Ampere	12 AWG / 3 mm ²	12 AWG / 3 mm ²	12 AWG / 3 mm ²
230 VAC	3.5 Ampere	12 AWG / 3 mm ²	12 AWG / 3 mm ²	12 AWG / 3 mm ²

Seafari 350

Operating Voltage	Maximum Load	Recommended Minimum Wire Size Length of run		
	Amperage	10 Ft / 3 meter	20 Ft / 6 meter	30 Ft / 9 meter
115 VAC	19 Ampere	10 AWG / 5 mm ²	10 AWG / 5 mm ²	10 AWG / 5 mm ²
230 VAC	9.5 Ampere	12 AWG / 3 mm ²	12 AWG / 3 mm ²	12 AWG / 3 mm ²

RECOMMENDED POWER WIRE SIZE TO BOOSTER PUMP:

Seafari 170

Operating Voltage	Maximum Load	Recommended Minimum Wire Size Length of run		
	Amperage	10 Ft / 3 meter	20 Ft / 6 meter	30 Ft / 9 meter
12 VDC	5 Ampere	14 AWG / 2 mm ²	14 AWG / 2 mm ²	14 AWG / 2 mm ²
24 VDC	2.5 Ampere	14 AWG / 2 mm ²	14 AWG / 2 mm ²	14 AWG / 2 mm ²
115 VAC	1 Ampere	14 AWG / 2 mm ²	14 AWG / 2 mm ²	14 AWG / 2 mm ²
230 VAC	.5 Ampere	14 AWG / 2 mm ²	14 AWG / 2 mm ²	14 AWG / 2 mm ²

Seafari 350

Operating Voltage	Maximum Load	Recommended Minimum Wire Size Length of run		
	Amperage	10 Ft / 3 meter	20 Ft / 6 meter	30 Ft / 9 meter
115 VAC	6 Ampere	14 AWG / 2 mm ²	14 AWG / 2 mm ²	12 AWG / 3 mm ²
230 VAC	3 Ampere	14 AWG / 2 mm ²	14 AWG / 2 mm ²	14 AWG / 2 mm ²

7. Wire Size Cross Reference American Wire Gauge (AWG) vs. Metric Wire Sizes

AWG	Diameter Inch	Square Inch (In ²)	Diameter Millimeters	Square Millimeters (mm ²)
0000	0.4600	0.1661	11.6840	107.1649
000	0.4096	0.1317	10.4038	84.9683
00	0.3648	0.1045	9.2659	67.3980
0	0.3249	0.0829	8.2525	53.4609
1	0.2893	0.0657	7.3482	42.3871
2	0.2576	0.0521	6.5430	33.6069
3	0.2294	0.0413	5.8268	26.6516
4	0.2043	0.0328	5.1892	21.1385
6	0.1620	0.0206	4.1148	13.2913
8	0.1285	0.0130	3.2639	8.3626
10	0.1019	0.0082	2.5883	5.2588
12	0.0808	0.0051	2.0523	3.3064
14	0.0641	0.0032	1.6281	2.0809
16	0.0508	0.0020	1.2903	1.3070
18	0.0403	0.0013	1.0236	0.8225
20	0.0320	0.0008	0.8128	0.5186
22	0.0254	0.0005	0.6452	0.3267

American Wire Gauge AWG	dia inch	sq. inch	Metric Wire Gauge dia mm	sq mm	Metric Wire Size mm ²
0000	0.4600	0.1661	11.6840	107.1649	100
000	0.4096	0.1317	10.4038	84.9683	85
00	0.3648	0.1045	9.2659	67.3980	65
0	0.3249	0.0829	8.2525	53.4609	50
1	0.2893	0.0657	7.3482	42.3871	40
2	0.2576	0.0521	6.5430	33.6069	32
3	0.2294	0.0413	5.8268	26.6516	32
4	0.2043	0.0328	5.1892	21.1385	19
6	0.1620	0.0206	4.1148	13.2913	13
8	0.1285	0.0130	3.2639	8.3626	8
10	0.1019	0.0082	2.5883	5.2588	5
12	0.0808	0.0051	2.0523	3.3064	3
14	0.0641	0.0032	1.6281	2.0809	2
16	0.0508	0.0020	1.2903	1.3070	1
18	0.0403	0.0013	1.0236	0.8225	0.8
20	0.0320	0.0008	0.8128	0.5186	0.5
22	0.0254	0.0005	0.6452	0.3267	0.35

WIRING DIAGRAMS

Seafari 170 12 VDC

Seafari 170 24 VDC

Seafari 170 115 / 230 VAC

Seafari 350 115 / 230 VAC

Refer to the appropriate individual wiring diagram applicable to the specific model and power set up of your system on the following pages.

SEAFARI 170 ELECTRICAL DIAGRAM 12 VDC Controller

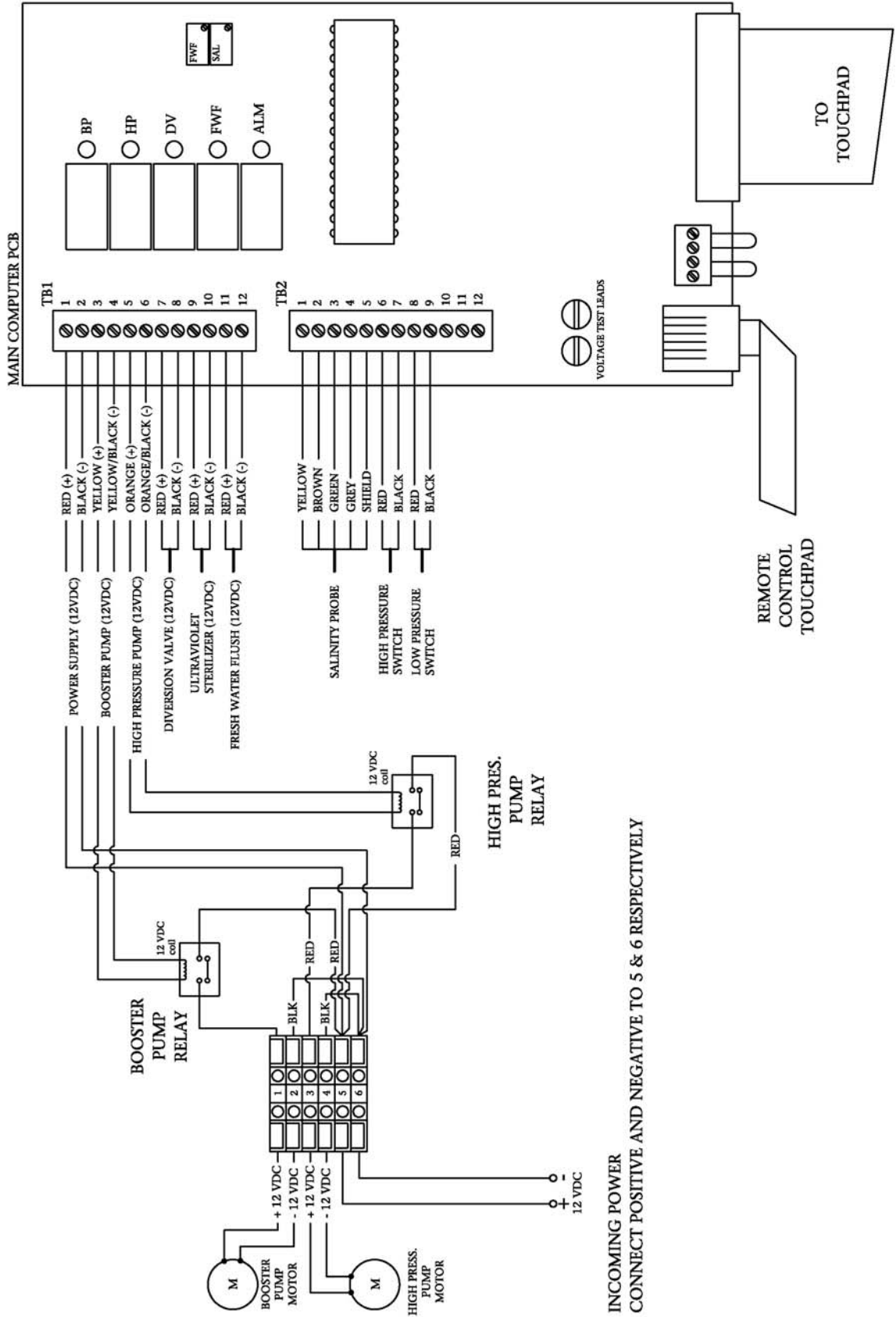

SEAFARI 170 ELECTRICAL DIAGRAM 24 VDC Controller

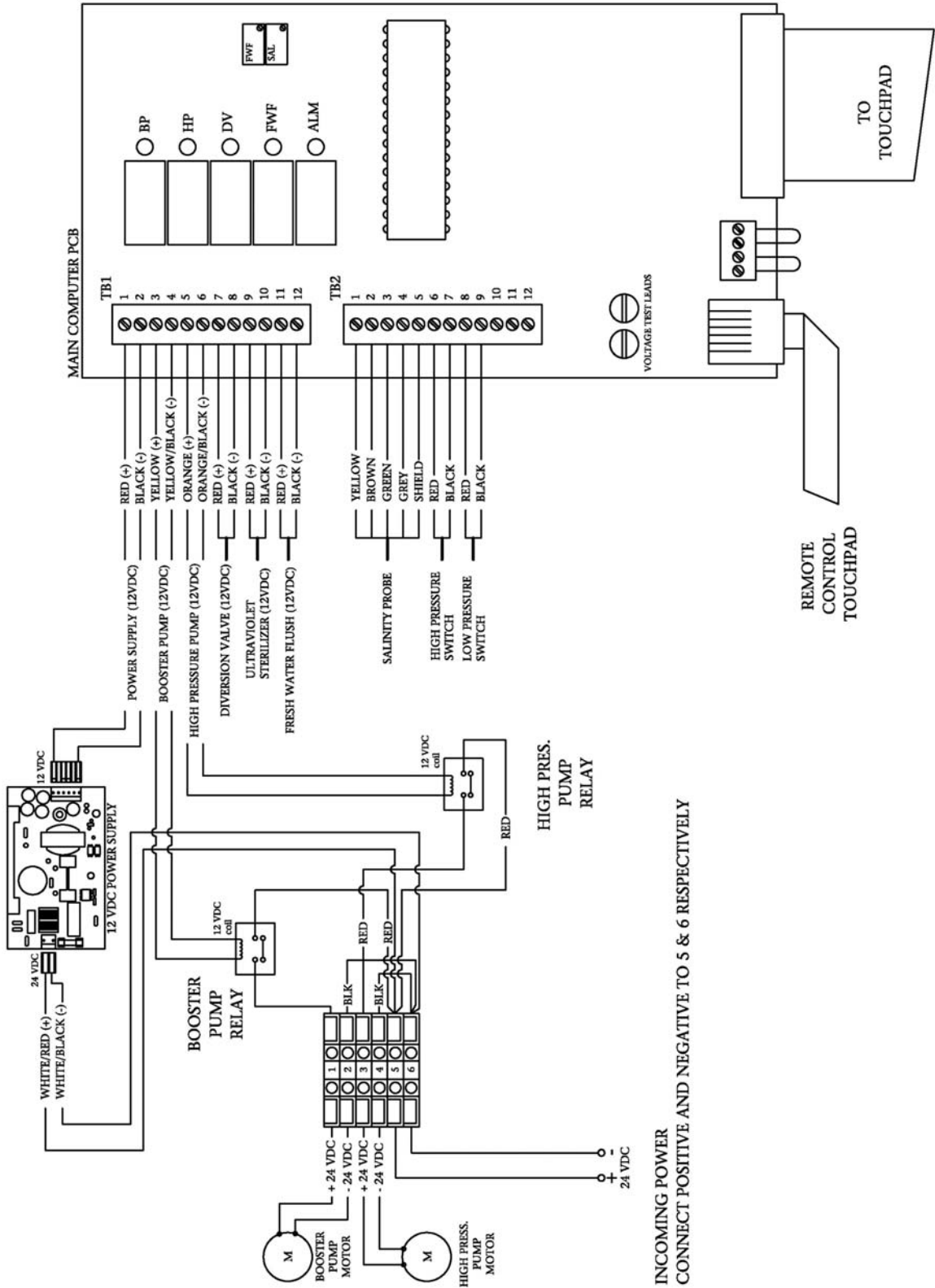

SEAFARI 170 ELECTRICAL DIAGRAM

110/220 VAC Single Phase Controller

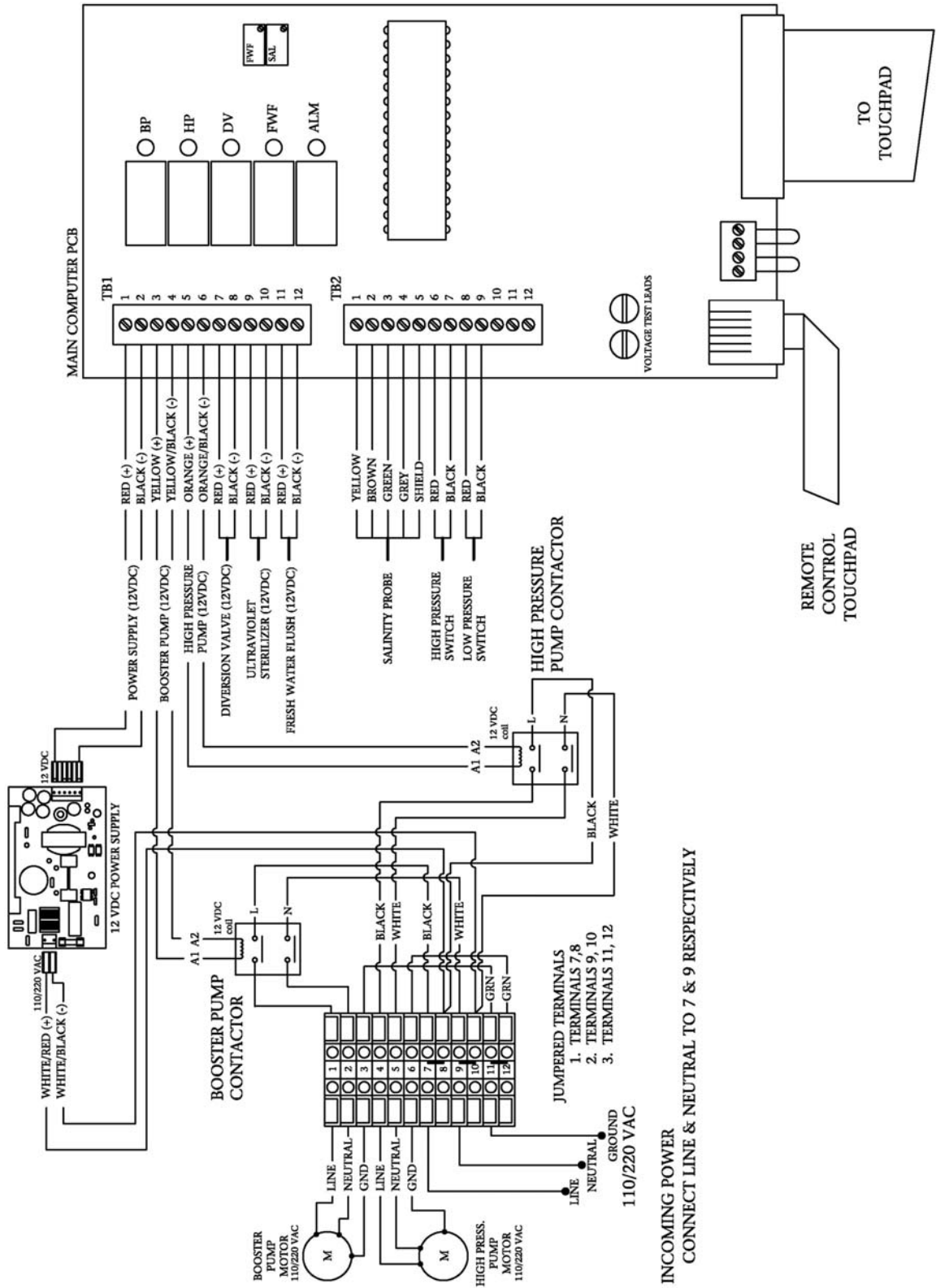

INCOMING POWER
CONNECT LINE & NEUTRAL TO 7 & 9 RESPECTIVELY

SEAFARI 350 ELECTRICAL DIAGRAM

110/220 VAC Single Phase Controller

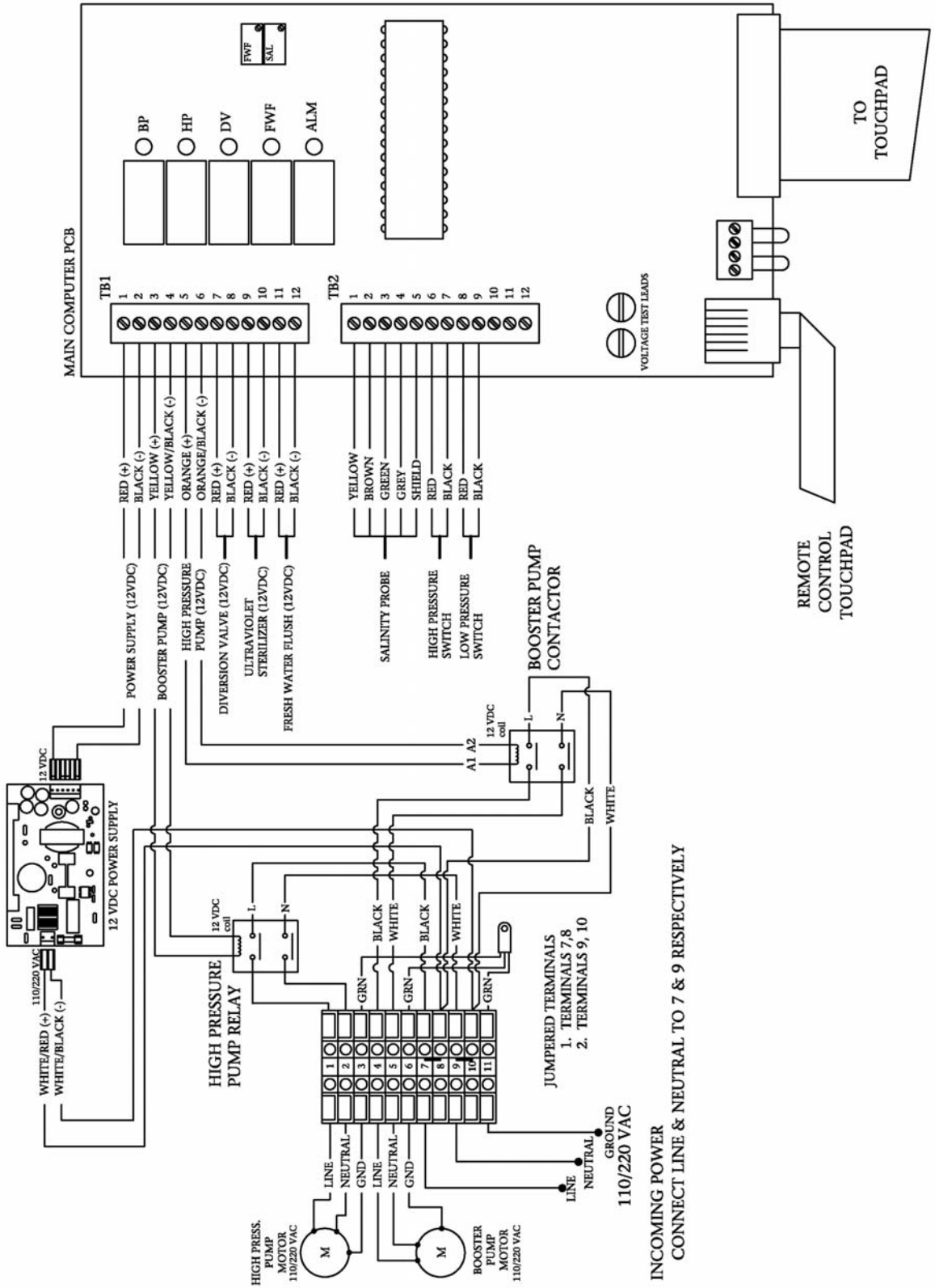

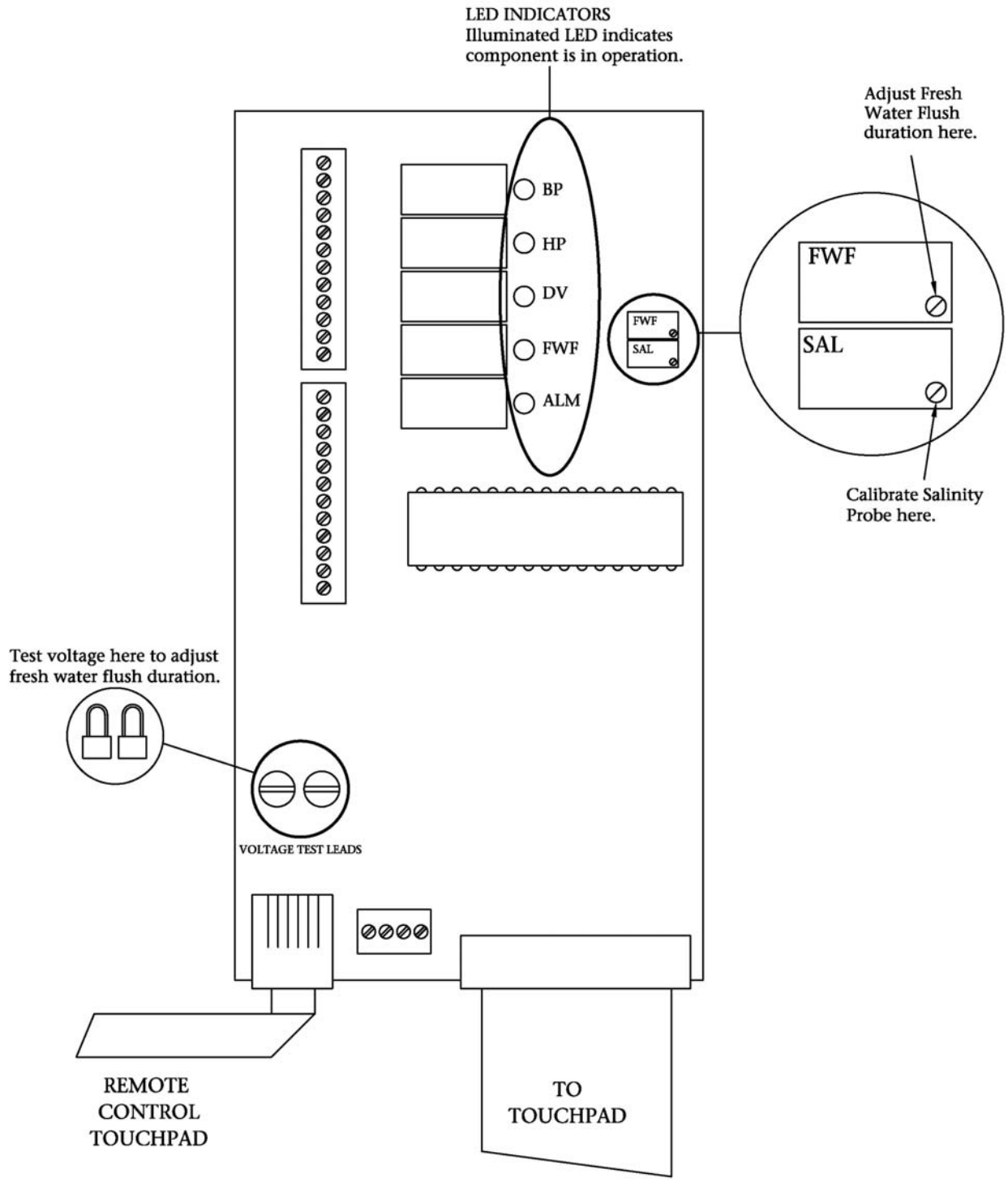

SECTION 8

CONVERSION CHARTS

**MICRON / INCH / MESH
COMPARISON MEASUREMENTS**

MICRON	INCH	INCH	MESH (opening)
1	.00003937	.0070	100
5	.00019685	.0075	90
10	.00039370	.0075	80
15	.00059055	.0078	70
20	.00078740	.0110	60
25	.00098425	.0130	50
30	.00118110	.0180	40
40	.00157480	.0260	30
50	.00196850	.0410	20
75	.00295275	.0850	10
100	.00393700	.1770	5
200	.00787400	.9370	1

TEMPERATURES CELSIUS vs FAHRENHEIT

CONVERSION CHART

F	C	F	C
0	-32	122	50
32	0	131	55
41	5	140	60
50	10	149	65
59	15	158	70
68	20	167	75
78	25	176	80
86	30	185	85
95	35	194	90
104	40	203	95
113	45	212	100

$$\text{CELSIUS} = 0.556 (\text{F} - 32)$$

$$\text{FAHRENHEIT} = (1.8 \text{ C}) + 32$$



TEMPERATURE EFFECT COMPARISON CHART

(At 820 psi & 35,000 ppm TDS NaCl feed water conditions)

The Temperature Effect Chart on this page illustrates the loss or gain of productivity across the RO membrane.

To determine what normal (in spec.) flow of the RO membrane would be at 77° F / 25° C follow these directions:

- 1) Determine feed source temperature.
- 2) Locate the corresponding temperature on the chart
- 3) Follow the corresponding temperature in a vertical line up to the plotted production line.
- 4) From this temperature point at the production line, move left horizontally to the plotted productivity percent.
- 5) Calculate the system's present productivity in U.S. gallons per day by multiplying the gallon per hour product water flow meter reading by 24.
- 6) Divide the figure reached in step 5 above, present gallon per day productivity, by the plotted productivity percentage from step 4 above. The answer will be equivalent to the membranes present productivity at specification test parameters, 820 psi & 77° F / 25° C.

Example:

- 1) With the system operating at 820 psi.
- 2) Present feed temperature is 61° F or 16° C.
- 3) Plotted productivity is therefore 72% of normal.
- 4) The system is a 400 gallon per day model and it is presently producing 280 gallons per day.
- 5) 280 gallons per day divided by .72 equals 388 gallons per day calculated productivity. The system is rated at 400 gallons per day ±15% (340 to 460 gallons per day). Therefore, the system is within specifications at 280 gallons per day actual productivity at 61° F/16° C, 820 psi and 35,000 ppm feed.

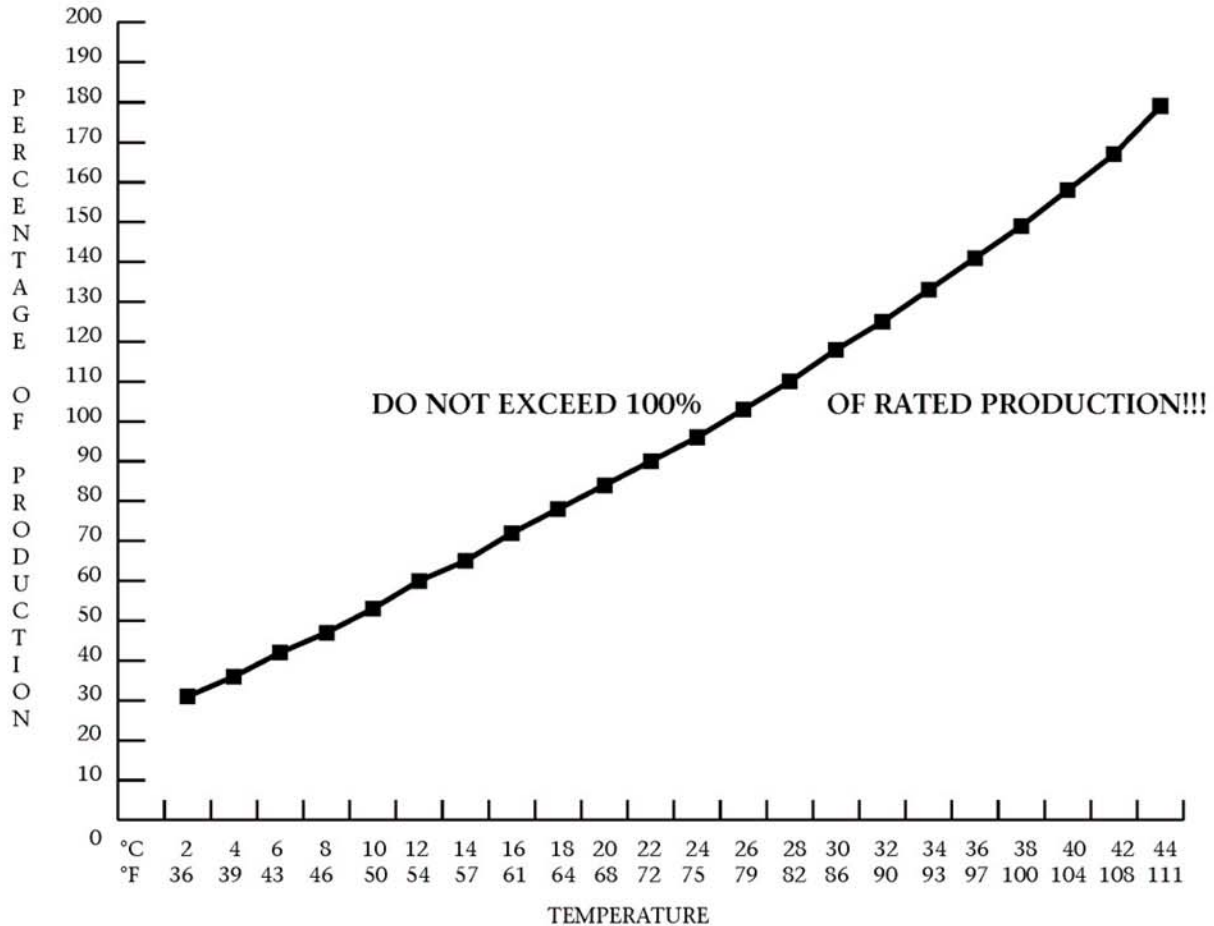



**Horizon
Reverse
Osmosis™**

Pioneer of fresh water since 1975

**SEAWATER TEMPERATURE
&
PRESSURE EFFECTS CHART**

(Do not use this chart for brackish water systems & applications)

As the seawater temperature increases, the Horizon Reverse Osmosis System pressure must be adjusted so that the system achieves no greater than 100% of rated product water flow. Product water flow greater than 100% of rated product water flow will cause premature fouling of the HRO RO membrane element. This will lead to more frequently required cleaning and void all warranties of the SRC RO membrane element.

DO NOT EXCEED 100% OF RATED PRODUCTION!!!

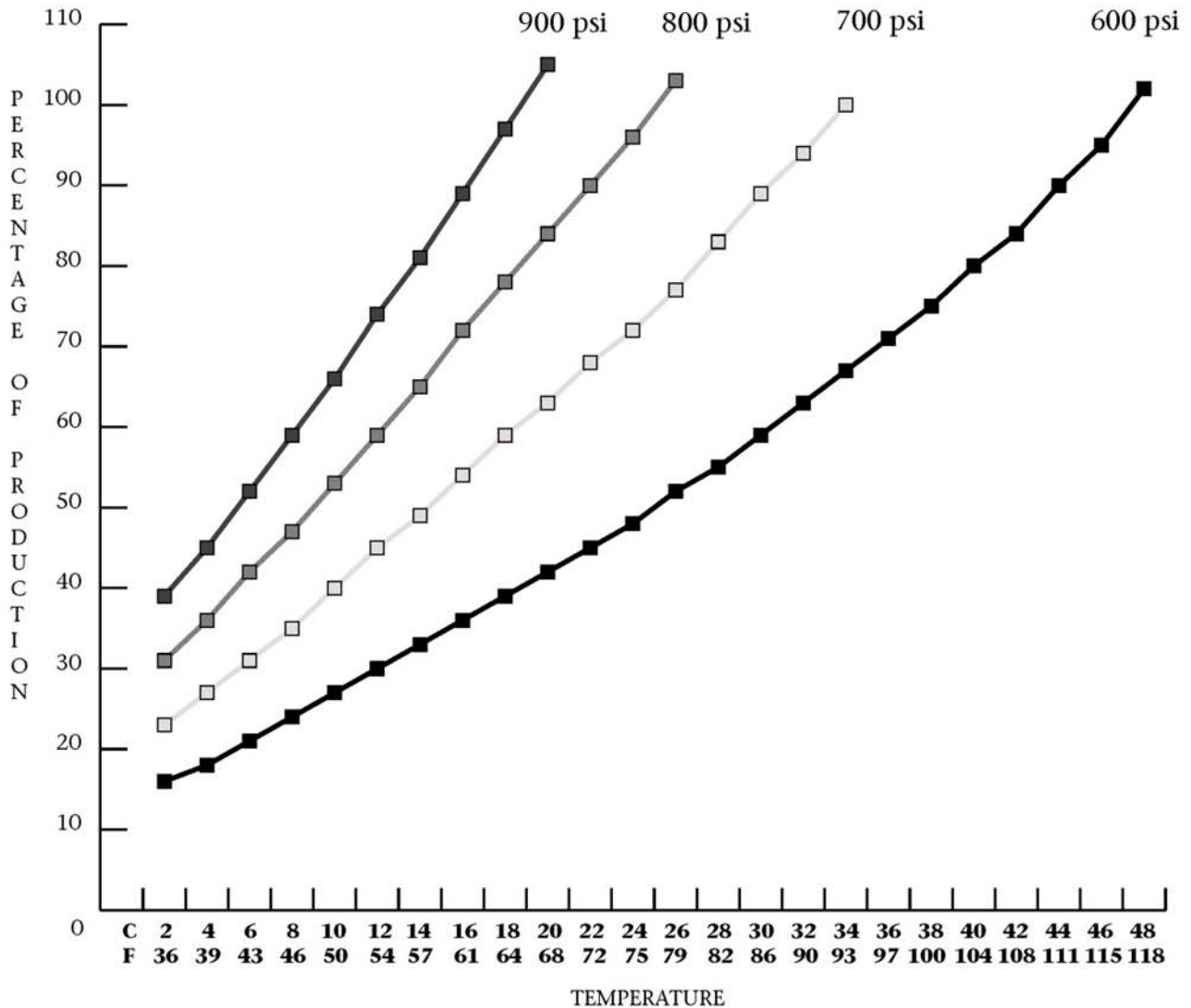

WATER COMPARISON CHART

GALLONS / VOLUME / WEIGHT

U.S. GALLON	CUBIC FEET	CUBIC YARD	CUBIC METER	TON SHORT	TON METRIC
1	0.13	0.005	0.004	0.004	0.004
5	0.67	0.025	0.019	0.021	0.019
10	1.34	0.050	0.038	0.041	0.038
25	3.34	0.129	0.10	0.104	0.094
50	6.68	0.248	0.19	0.208	0.189
100	13.37	0.50	0.38	0.42	0.38
200	26.74	0.99	0.76	0.83	0.76
300	40.10	1.49	1.14	1.25	1.13
400	53.47	1.98	1.51	1.67	1.51
500	66.84	2.48	1.89	2.08	1.89
600	80.21	2.97	2.27	2.50	2.27
700	93.58	3.47	2.65	2.92	2.65
800	106.94	3.96	3.03	3.33	3.02
900	120.31	4.46	3.41	3.75	3.40
1,000	133.68	4.95	3.79	4.17	3.78
2,500	334.20	12.38	9.46	10.41	9.45
5,000	668.40	24.76	18.93	20.83	18.89
7,500	1002.60	37.13	28.39	31.24	28.34
10,000	1336.81	49.51	37.85	41.65	37.79
25,000	3342.00	123.80	94.60	104.10	94.50
50,000	6684.00	247.60	189.30	208.30	188.90
75,000	1006.00	371.30	283.90	312.40	283.40
100,000	13368.06	495.11	378.54	416.50	377.85

- 1 U.S. GALLON = 231. CU. INCH
- 1 U.S. GALLON OF WATER = 8.33 LBS.
- 1 SHORT TON = 2000 LBS.
- 1 METRIC TON = 2204.6 LBS.
- 1 CU. INCH OF WATER = 0.0360 LBS.
- 1 CU. FOOT OF WATER = 62.4 LBS.
- 1 IMPERIAL GALLON OF WATER = 10.0 LBS.
- 1 GALLON = 3.7854 LITERS
- 1 CUBIC METER = 1000 LITERS
- 1 CUBIC METER = 264 GALLONS

PPM CONVERSION CHART

SPECIFIC CONDUCTANCE IN MICROMHOS	SPECIFIC RESISTANCE IN OHMS	DISSOLVED SOLIDS P.P.M.	RESISTANCE*		P.P.M.
			MHOS	OHMS	
.0385	26,000,000	NONE	250.0	4,000	125
.0556	18,000,000	.02777	256.4	3,900	128
.0625	16,000,000	.03125	263.2	3,800	132
.0714	14,000,000	.03571	270.3	3,700	135
.0833	12,000,000	.04166	277.8	3,600	139
.1	10,000,000	.05	285.7	3,500	143
.125	8,000,000	.0625	294.1	3,400	147
.167	6,000,000	.08333	303.0	3,300	152
.2	5,000,000	.1	312.0	3,200	156
.25	4,000,000	.125	322.5	3,100	161
.5	2,000,000	.25	333.3	3,000	166
1	1,000,000	.5	344.8	2,900	172
2	500,000	1	357.0	2,800	179
4	250,000	2	370.4	2,700	185
6	166,666	3	384.6	2,600	192
8	125,000	4	400.0	2,500	200
10	100,000	5	416.6	2,400	208
12	83,333	6	434.8	2,300	217
14	71,428	7	454.5	2,200	227
16	62,500	8	476.2	2,100	238
18	55,555	9	500.0	2,000	250
20	50,000	10	526.3	1,900	263
22	45,454	11	555.5	1,800	278
24	41,666	12	588.2	1,700	294
26	38,461	13	625.0	1,600	312
28	35,714	14	666.6	1,500	333
30	33,333	15	714.2	1,400	357
40	25,000	20	769.2	1,300	384
50	20,000	25	833.3	1,200	416
60	16,666	30	909.0	1,000	500
70	14,286	35	1,000	1,000	500
80	12,500	40	1,111	900	555
100	10,000	50	1,250	800	625
120	8,333	60	1,428	700	714
140	7,142	70	1,666	600	833
160	6,250	80	2,000	500	1,000
180	5,555	90	2,500	400	1,250
200	5,000	100	3,333	300	1,667
			5,000	200	2,500
			10,000	100	5,000

*Approximate dissolved solids expressed as Calcium Carbonate (CaCO3)

PRESSURE COMPARISON

psi	Kg/cm ²	"Hg Vacuum	bar	kPa	atmosphere
1	0.0704	2.036	0.0689	6.895	0.0681
14.22	1	28.96	0.981	98.07	0.968
0.4912	0.0345	1	0.0339	3.386	0.03342
14.504	1.02	29.53	1	100	0.987
0.14504	0.0102	0.295	0.01	1	0.00987
14.7	1.033	29.92	1.013	101.3	1

METRIC / U.S. CUSTOMARY UNIT EQUIVALENTS

multiply:	by:	to get or multiply:	by:	to get:
LINEAR				
inch	x	25.4	=	millimeters(mm)
foot	x	0.3048	=	meters(m)
yard	x	0.9144	=	meters(m)
mile	x	1.6093	=	kilometers(km)
inch	x	2.54	=	centimeters(cm)
VOLUME				
fluid oz	x	29.57	=	milliliters (ml)
U.S. quart	x	0.94635	=	liters(l)
U.S. gallon	x	3.7854	=	liters(l)
feet ³	x	28.317	=	liters
feet ³	x	0.02832	=	meters ³
yard ³	x	0.7646	=	meters ³
MASS				
ounces	x	28.35	=	grams(g)
pounds	x	0.4536	=	kilograms (kg)
tons (2000lb)	x	907.18	=	kilograms (kg)
tons (2000lb)	x	0.90718	=	metric tons(t)

WIRE SIZE CROSS REFERENCE CHART:

American Wire Gauge			Metric Wire Gauge		Metric Wire
AWG	dia inch	sq. inch	dia mm	sq mm	Size mm ²
0000	0.4600	0.1661	11.6840	107.1649	100
000	0.4096	0.1317	10.4038	84.9683	85
00	0.3648	0.1045	9.2659	67.3980	65
0	0.3249	0.0829	8.2525	53.4609	50
1	0.2893	0.0657	7.3482	42.3871	40
2	0.2576	0.0521	6.5430	33.6069	32
3	0.2294	0.0413	5.8268	26.6516	32
4	0.2043	0.0328	5.1892	21.1385	19
6	0.1620	0.0206	4.1148	13.2913	13
8	0.1285	0.0130	3.2639	8.3626	8
10	0.1019	0.0082	2.5883	5.2588	5
12	0.0808	0.0051	2.0523	3.3064	3
14	0.0641	0.0032	1.6281	2.0809	2
16	0.0508	0.0020	1.2903	1.3070	1
18	0.0403	0.0013	1.0236	0.8225	.8
20	0.0320	0.0008	0.8128	0.5186	.5
22	0.0254	0.0005	0.6452	0.3267	.35

Section 9

Exploded Parts Views

AVAILABLE TUBE FITTINGS

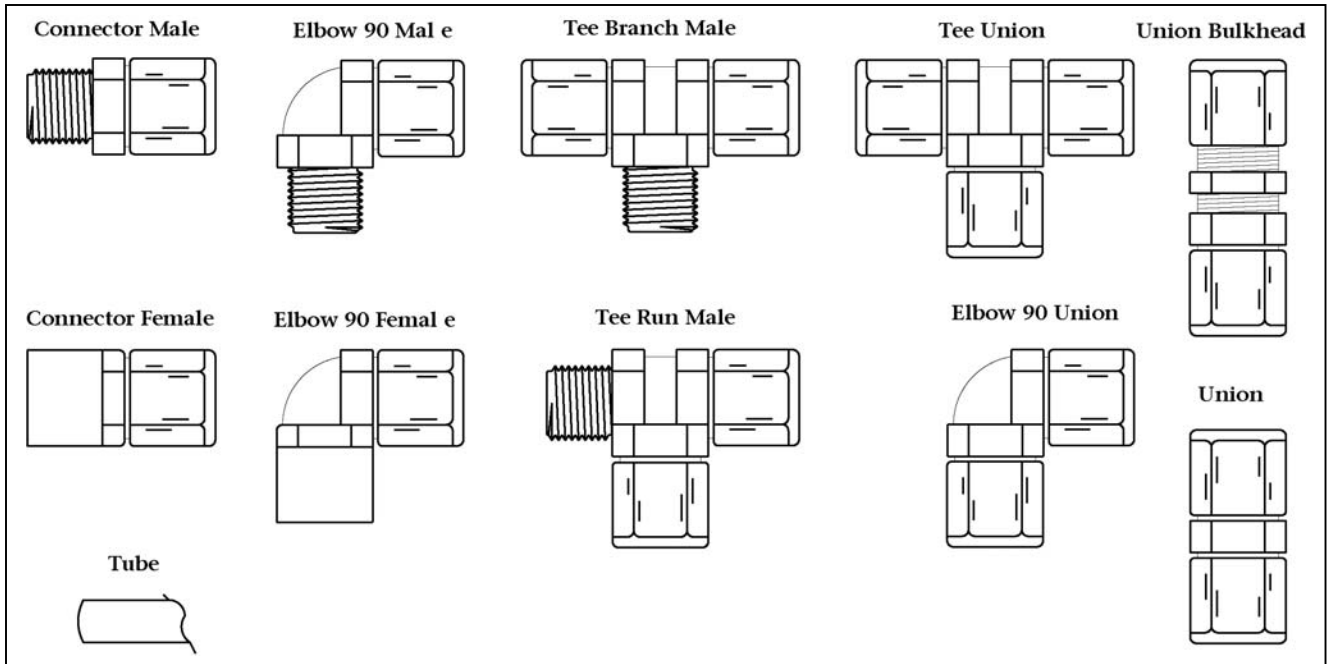

Specify Tube Size and Specify Pipe Size and Specify Male or Female

1/4" O.D.	1/4	MNPT	FNPT
3/8" O.D.	3/8	MNPT	FNPT
1/2" O.D.	1/2	MNPT	FNPT
5/8" O.D.	3/4	MNPT	FNPT

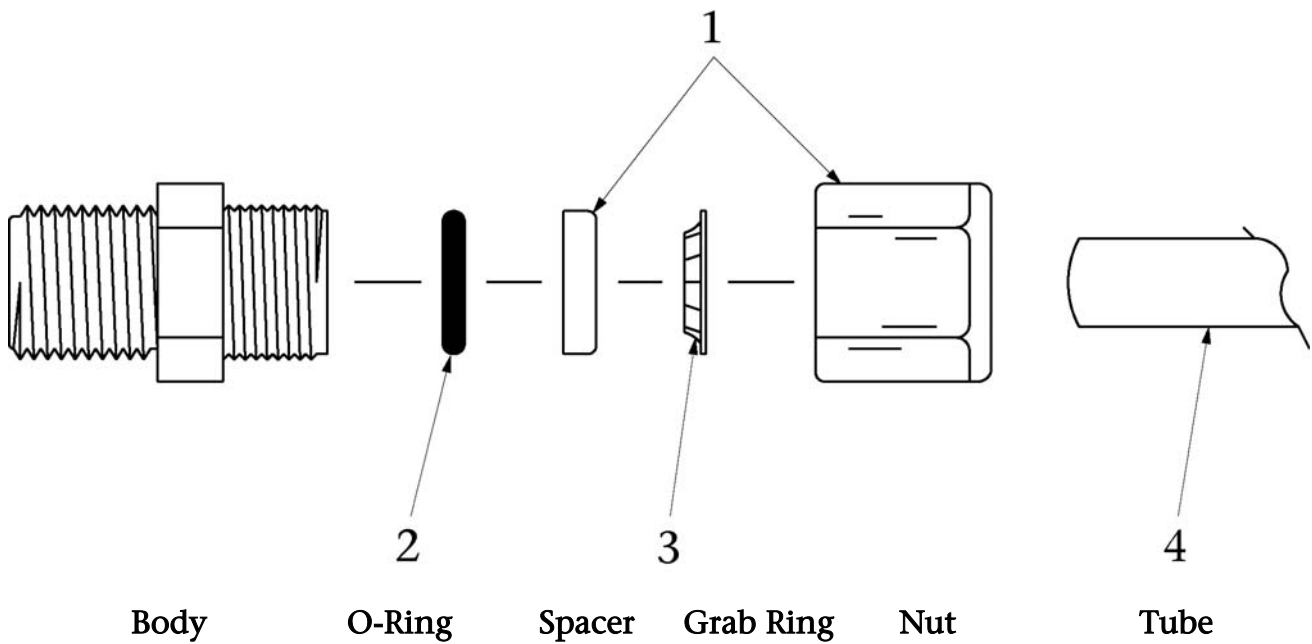

SEA STRAINER

ITEM NO.	QTY.	U/M	PART NUMBER	DESCRIPTION
1 -- 7	1	EACH	B006220002	SEA STRAINER ASSY 170
1	1	EACH	0412034678	SEA STRAINER-3/8"
2	1	EACH	2614100278	O-RING 226 SEA STRAINER 3/8"
3	1	EACH	0804743278	MESH SCREEN STRAINER 3/8"
4	2	EACH	0204021869	ELB90 3/8 TUBE X 3/8 MPT PLAST
5	1	EACH	20200403010	BRACKET SEA STRAINER 3/8"
6	2	EACH	065080028000	WASHER FLAT #10 NYLON
7	2	EACH	061170628016	SC PHIL PAN "A" 10 X 1 SS

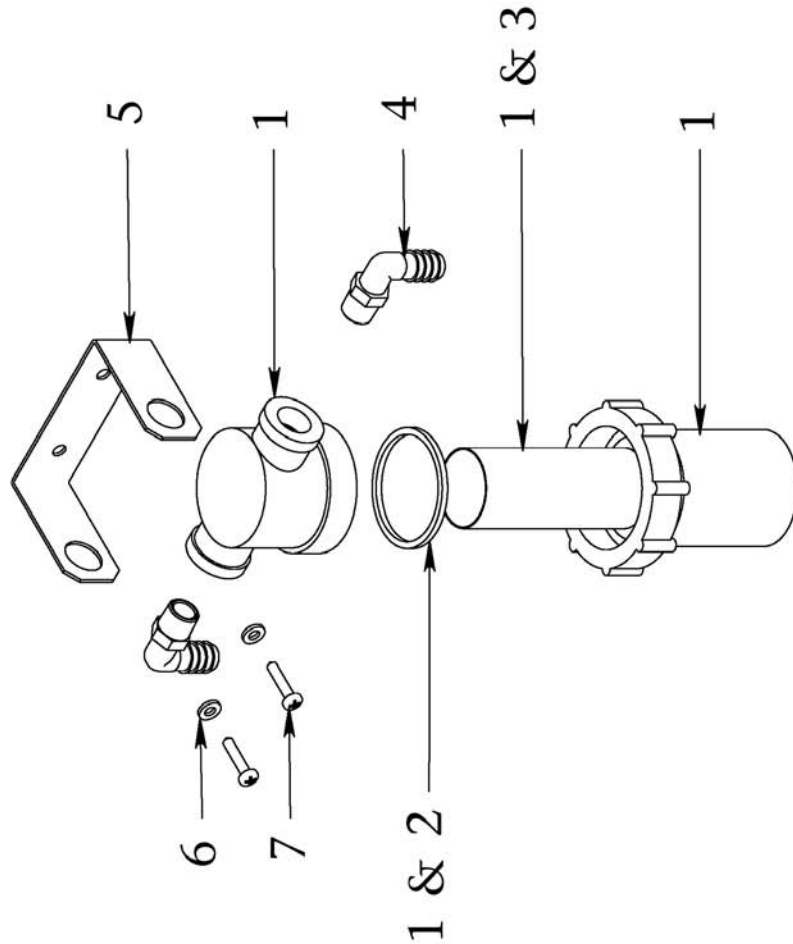

BOOSTER PUMP with ELECTRIC MOTOR SEAFARI 170

ITEM NO.	QTY.	PART NUMBER	DESCRIPTION
1-4	1	B016220001	SF 170 Booster Pump Assy 12 VDC
-	1	B016220002	SF 170 Booster Pump Assy 24 VDC
-	1	B016220003	SF 170 Booster Pump Assy 115 VAC
-	1	B016220004	SF 170 Booster Pump Assy 220 VAC
1	1	12124001SF	Booster Pump/Motor 12 VDC
-	1	12124002SF	Booster Pump/Motor 24 VDC
-	1	12124003SF	Booster Pump/Motor 115 VAC
-	1	12124004SF	Booster Pump/Motor 220 VAC
2	2	0112651900	Adapter Nylon 3/8" MPT 1/2" Barb
3	4	065080028000	Nylon Washer #10
4	4	061170628020	SC Phil "A" #10 x 1 1/4" SS

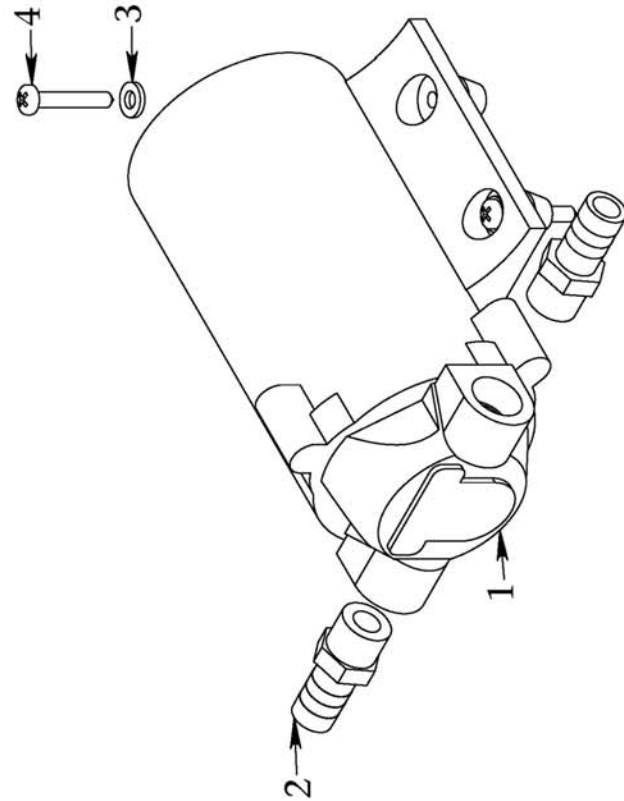

BOOSTER PUMP with ELECTRIC MOTOR SEAFARI 350

ITEM NO.	QTY.	U/M	PART NUMBER	DESCRIPTION
1 -- 5	1	EACH	B016230001	BOOSTER PUMP ASSY 350
1	1	EACH	B016080001	BOOSTER PUMP/MOTOR-AS 1 PHASE
	1	EACH	2625120172	GASKET BOOSTER PUMP-AS
	1	EACH	2625130172	SEAL/SEAT BOOSTER PUMP-AS
	1	EACH	29210133572	IMPELLER B25P BRASS
2	1	EACH	1904010043	STRAIN RELIEF 3217 1/2" GREY
3	1	EACH	0112652500	ADAP 1/2 MNPT X 1/2 BARB NYLON
4	1	EACH	0121842369	CONN RED 1/2 FPT X 1/4 MPT BRA
5	1	EACH	0112072500	ELB90 1/2 MPT X 1/2 BARB NYLON

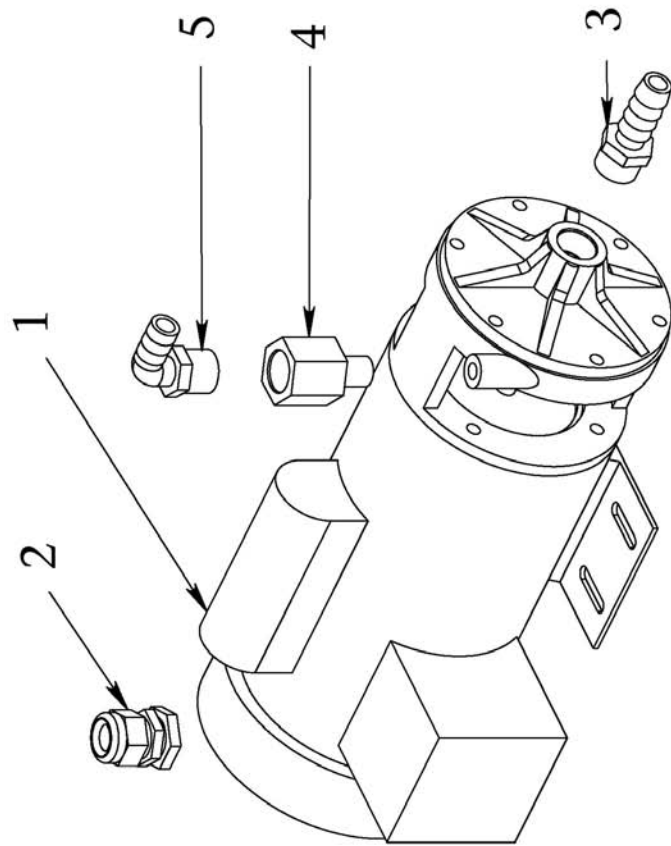

BOOSTER PUMP with ELECTRIC MOTOR SEAFARI 350

ITEM NO.	QTY.	U/M	PART NUMBER	DESCRIPTION
A	1	EACH		Volute Cover
B	1	EACH	2625120172	GASKET BOOSTER PUMP-AS
C	1	EACH	29210133572	IMPELLER B25P BRASS
D	1	EACH		Shaft w/Set Screws
E	6	EACH		Volute Bolts
F	4	EACH		Motor Bolts
G	1	EACH		Impeller Lockdown
H	1	EACH		Volute Bracket
J	1	EACH	2625130172	SEAL/SEAT BOOSTER PUMP-AS
K	1	EACH		Motor 115/123 VAC 50/60 Hz Single Phase

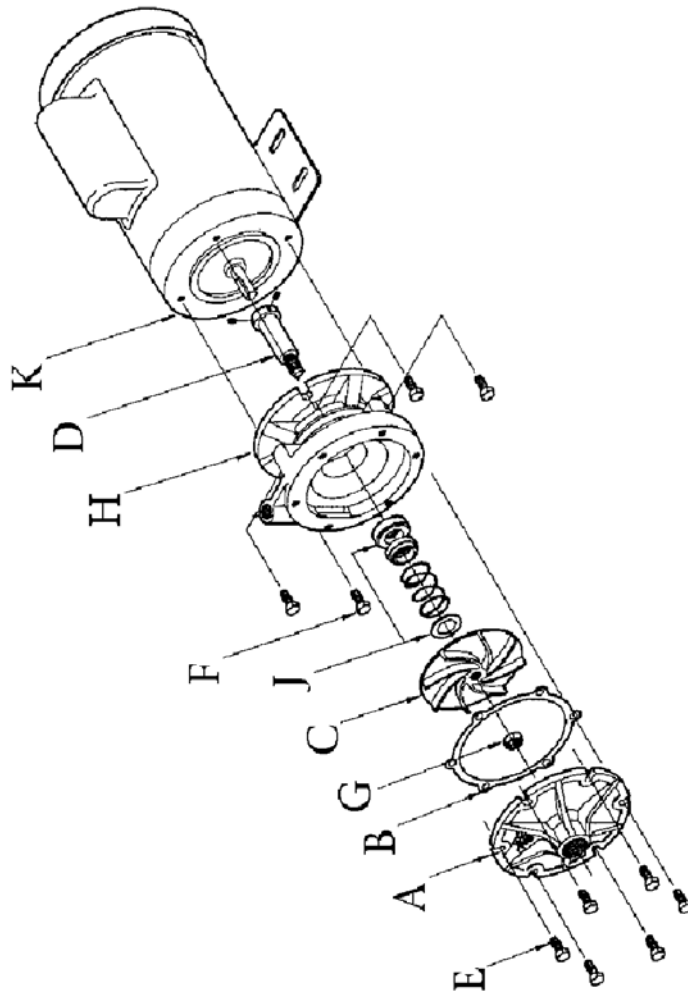

PLANKTON FILTER

ITEM NO.	QTY.	U/M	PART NUMBER	DESCRIPTION
1 -- 8	1	EACH	B008220001	PLANKTON FILTER ASSEMBLY 170 & 350
1	1	EACH	0713020573	FILTER HOUSING/LID 3/8 X 10
2	1	EACH	2614010473	O-RING 237 BLUE HOUSING
3	1	EACH	0805823578	ELEMENT PLANKTON
4	2	EACH	0112071900	ELB90 3/8 X 1/2 BARB NYLON
5	1	EACH	20200402100	BRACKET PREFILTER/CHRCCL/PLNKTN
6	8	EACH	065080028000	WASHER FLAT #10 NYLON
7	4	EACH	061170628016	SC PHIL PAN "A" 10 X 1 SS
8	4	EACH	061170628020	SC PHIL PAN "A" 10 X 1 1/4 SS

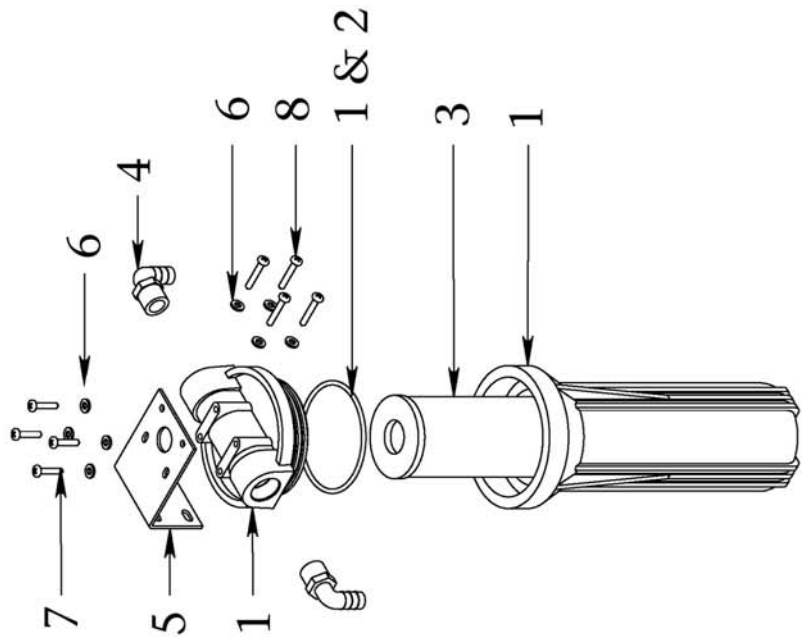

PREFILTER ASSY 170

ITEM NO.	QTY.	U/M	PART NUMBER	DESCRIPTION
1 -- 8	1	EACH	B107220002	PREFILTER ASSY 170
1	1	EACH	0713020573	FILTER HOUSING/LID 3/8 X 10
2	1	EACH	2614010473	O-RING 237 BLUE HOUSING
3	1	EACH	0801060157	ELEMENT PREFILTER 10/05
4	2	EACH	0112071900	ELB90 3/8 X 1/2 BARB NYLON
5	1	EACH	20200402100	BRACKET PREFILTER/CHRCL/PLNKTN
6	8	EACH	065080028000	WASHER FLAT #10 NYLON
7	4	EACH	061170628016	SC PHIL PAN "A" 10 X 1 SS
8	4	EACH	061170628020	SC PHIL PAN "A" 10 X 1 1/4 SS

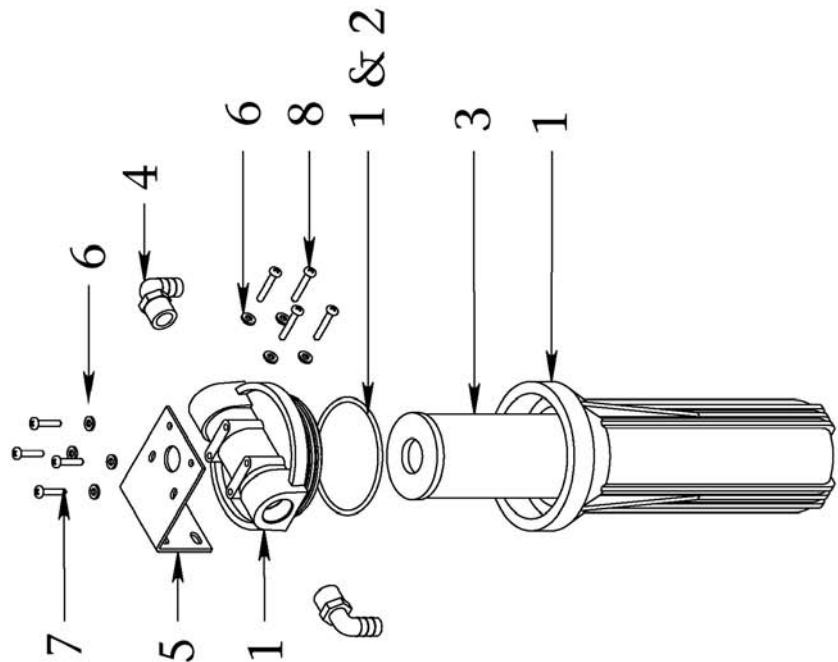

CAUTION: Do not use third party prefilter elements, use only Horizon Reverse Osmosis Prefilter Elements. Third party prefilter elements on the market do not properly fit, the seams fall apart, they will allow by-pass resulting in premature fouling of the R.O. Membrane Element.

CAUTION: Do not use "string wound" or "fiber" prefilter elements. These type of elements are designed for the Photographic Film Developing industry. When used in sea water they will plug up rapidly in 1/10th or less the time causing frequent shut down of the system and very frequent changing resulting in very high cost of maintenance.

PREFILTER ASSY 350

ITEM NO.	QTY.	U/M	PART NUMBER	DESCRIPTION
1 --11	1	EACH	B107230001	PREFILTER ASSY 350
5	1	EACH	20200402100	BRACKET PREFILTER/CHRL/PLNKTN
1	1	EACH	0713020573	FILTER HOUSING/LID 3/8 X 10
3	1	EACH	0801060157	ELEMENT PREFILTER 10/05
4	2	EACH	0112071900	ELB90 3/8 X 1/2 BARB NYLON
7	4	EACH	061170628016	SC PHIL PAN "A" 10 X 1 SS
11	4	EACH	061142145012	BOLT HEX 1/4-20 X 3/4 SS
8	4	EACH	065070045000	NUT LOCKING 1/4-20 FLANGED NYL
9	4	EACH	061100043000	WASHER FLAT OS 1/4"SS
10	4	EACH	065080028000	WASHER FLAT #10 NYLON
1 & 2	1	EACH	2614010473	O-RING 237 BLUE HOUSING

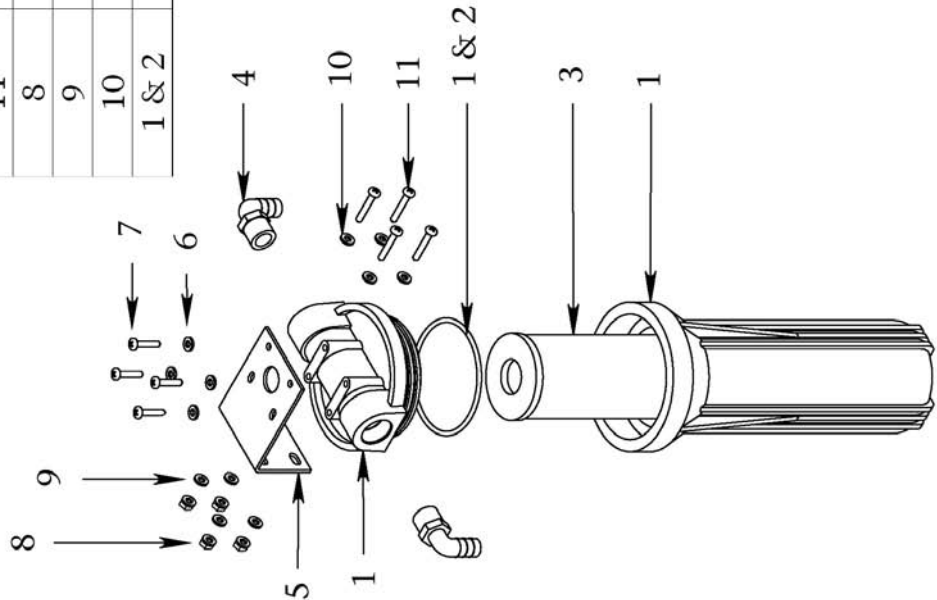

CAUTION: Do not use third party prefilter elements, use only Horizon Reverse Osmosis Prefilter Elements. Third party prefilter elements on the market do not properly fit, the seams fall apart, they will allow by-pass resulting in premature fouling of the R.O. Membrane Element.

CAUTION: Do not use "string wound" or "fiber" prefilter elements. These type of elements are designed for the Photographic Film Developing industry. When used in sea water they will plug up rapidly in 1/10th or less the time causing frequent shut down of the system and very frequent changing resulting in very high cost of maintenance.

LOW PRESSURE MANIFOLD

ITEM NO.	QTY.	U/M	PART NUMBER	DESCRIPTION
1 -- 5	1	EACH	B502220002	MANIFOLD LP ASSY 170/350
1	1	EACH	2301020658	SWITCH LOW PRES 6 PSI ORING PO
2	2	FEET	4910210720	WIRE 20 GA 2 COND. BLACK FLEX
2	2	EACH	2614015800	O-RING 011 GAUGE/PRES SWITCH
3	1	EACH	5333220900	MANIFOLD LP AW 170
4	2	EACH	0204090869	CONN 1/4 TUBE X 1/4 MPT PLASTI
5	2	EACH	061161130012	SC PHIL OVAL 10-24 X 3/4 SS

HIGH PRESSURE PUMP & ELECTRIC MOTOR SEAFARI 170 Direct Current 12 & 24 VDC

ITEM NO.	QTY.	U/M	PART NUMBER	DESCRIPTION
1 -- 16	1	EACH	B156220012	HP PUMP/MOTOR 12VDC AW 170
1 -- 16	1	EACH	B156220024	HP PUMP/MOTOR 24VDC AW 170
1	1	EACH	1218181422	HP PUMP 0.5 GPM
2	1	EACH	0112651900	ADAP 3/8 MPT X 1/2 BARB NYLON
3	1	EACH	0204020869	ELB90 1/4 TUBE X 1/4 MPT PLAST
4	1	EACH	0117291700	RB 3/8 MT X 1/4 FT SS
5	1	EACH	1317060800	ELB45 -4 FLARE X 1/4 MPT SS
6	1	EACH	0117341869	PLUG 3/8 MPT SS
	1	EACH	B652220001	HP PUMP-C PUMP KIT (SEALS & VALVES)
	1	EACH	B654220002	HP PUMP-C DISCHARGE VALVE REBUILD KIT
	1	EACH	B653220001	HP PUMP-C SEAL KIT
7	1	EACH	15093110CF	MOTOR 1/3 HP 12VDC
7	1	EACH	15103210CF	MOTOR 1/3 HP 24VDC
8	1	EACH	1904010043	STRAIN RELIEF 3217 1/2" GREY
9	4	EACH	061142157024	BOLT HEX 3/8-16 X 1 1/2 SS
10	4	EACH	061080056000	WASHER FLAT 3/8"SS
11	4	EACH	061120056000	WASHER SPLIT LOCK 3/8"SS
12	4	EACH	061142150016	BOLT HEX 5/16-18 X 1 SS
13	8	EACH	061100049000	WASHER FLAT OS 5/16"SS
14	4	EACH	061060050000	NUT HEX 5/16-18 W/INSERT SS
	2	EACH	3131660190	TERMINAL WIRE END 54130
	2	FEET	4942521318	WIRE 8 GA 2 COND. RED/BLK

HIGH PRESSURE PUMP & ELECTRIC MOTOR SEAFARI 170 Alternating Current 110/220 VAC

ITEM NO.	QTY.	U/M	PART NUMBER	DESCRIPTION
1 -- 14	1	EACH	B156220110	HP PUMP/MOTOR 110/220/56 AW 170
1	1	EACH	1218181422	HP PUMP 0.5 GPM
2	1	EACH	0117341869	PLUG 3/8 MPT SS
3	1	EACH	0112651900	ADAP 3/8 MPT X 1/2 BARB NYLON
4	1	EACH	0204020869	ELB90 1/4 TUBE X 1/4 MPT PLAST
5	1	EACH	0117291700	RB 3/8 MT X 1/4 FT SS
6	1	EACH	1317060800	ELB45 -4 FLARE X 1/4 MPT SS
7	4	EACH	061142157024	BOLT HEX 3/8-16 X 1 1/2 SS
8	4	EACH	061080056000	WASHER FLAT 3/8"SS
9	4	EACH	061120056000	WASHER SPLIT LOCK 3/8"SS
10	4	EACH	061142150016	BOLT HEX 5/16-18 X 1 SS
11	8	EACH	061100049000	WASHER FLAT OS 5/16"SS
12	4	EACH	061060050000	NUT HEX 5/16-18 W/INSERT SS
	1	EACH	B652220001	HP PUMP-C PUMP KIT (SEALS & VALVES)
	1	EACH	B654220002	HP PUMP-C DISCHARGE VALVE REBUILD KIT
	1	EACH	B653220001	HP PUMP-C SEAL KIT
13	1	EACH	15AG250912	MOTOR 1/3 HP 50/60/1
14	1	EACH	1904010543	STRAIN RELIEF 8400
	1	EACH	1904013543	STRAIN RELIEF 8423
	0.583	FEET	1928058543	CONDUIT 3/8" (FLEX) BLK
	6	EACH	3131383990	TERMINAL BUTT SPLICE RAA 18
	2	FEET	4900210904	WIRE 16 GA WHITE UL1015
	2	FEET	4900210901	WIRE 14 GA GREEN/YELLOW UL1015
	1	EACH	3131380990	TERMINAL RING BLUE RB867

HIGH PRESSURE PUMP SEAFARI 350 Alternating Current 110/220 VAC

ITEM NO.	QTY.	U/M	PART NUMBER	DESCRIPTION
1 -- 15	1	EACH	B156230001	HP PUMP/MOTOR 110/220/60HZ 350
1 -- 15	1	EACH	B156230002	HP PUMP/MOTOR 110/220/50HZ 350
1	1	EACH	1218181622	HP PUMP 1.5 GPM SS 350
2	1	EACH	0112071900	ELB90 3/8 X 1/2 BARB NYLON
3	1	EACH	0204020869	ELB90 1/4 TUBE X 1/4 MPT PLAST
4	1	EACH	0117341869	PLUG 3/8 MPT SS
5	1	EACH	0117291700	RB 3/8 MT X 1/4 FT SS
6	1	EACH	1317060800	ELB45 -4 FLARE X 1/4 MPT SS
	1	EACH	B652220001	HP PUMP-C PUMP KIT (SEALS & VALVES)
	1	EACH	B654220002	HP PUMP-C DISCHARGE VALVE REBUILD KIT
	1	EACH	B653220001	HP PUMP-C SEAL KIT
7	1	EACH	1534231010	MOTOR 1 HP 115/220/50/1
7	1	EACH	1535231010	MOTOR 1 HP 115/220/60/1
8	1	EACH	1904013543	STRAIN RELIEF 8423
	1	EACH	1904010543	STRAIN RELIEF 8400
	0.79	FEET	4928402800	CONDUIT 1/2" (FLEX) BLK
	2	FEET	4900210901	WIRE 14 GA GREEN/YELLOW UL1015
	10	FEET	4900210904	WIRE 16 GA WHITE UL1015
9	4	EACH	061142157024	BOLT HEX 3/8-16 X 1 1/2 SS
10	4	EACH	061120056000	WASHER SPLIT LOCK 3/8"SS
11	4	EACH	061080056000	WASHER FLAT 3/8"SS
12	4	EACH	061142150016	BOLT HEX 5/16-18 X 1 SS
13	8	EACH	061100049000	WASHER FLAT OS 5/16"SS
14	4	EACH	061060050000	NUT HEX 5/16-18 W/INSERT SS

HIGH PRESSURE HOSES

ITEM NO.	QTY.	U/M	PART NUMBER	DESCRIPTION
1 -- 2	1	EACH	B390220014	HOSE HP ASSY 170 INLET
1	2	EACH	1317481001	SWIVEL FITTING-4 TTC
2	1.25	FEET	2404063601	HOSE HP-4 GH194
1 -- 2	1	EACH	B390220015	HOSE HP ASSY 170 OUTLET
1	2	EACH	1317481001	SWIVEL FITTING-4 TTC
2	1.54	FEET	2404063601	HOSE HP-4 GH194
1 -- 2	1	EACH	B390220016	HOSE HP ASSY 350 INLET
1	2	EACH	1317481001	SWIVEL FITTING-4 TTC
2	1.25	FEET	2404063601	HOSE HP-4 GH194
1 -- 2	1	EACH	B390220017	HOSE HP ASSY 350 OUTLET
1	2	EACH	1317481001	SWIVEL FITTING-4 TTC
2	1.54	FEET	2404063601	HOSE HP-4 GH194

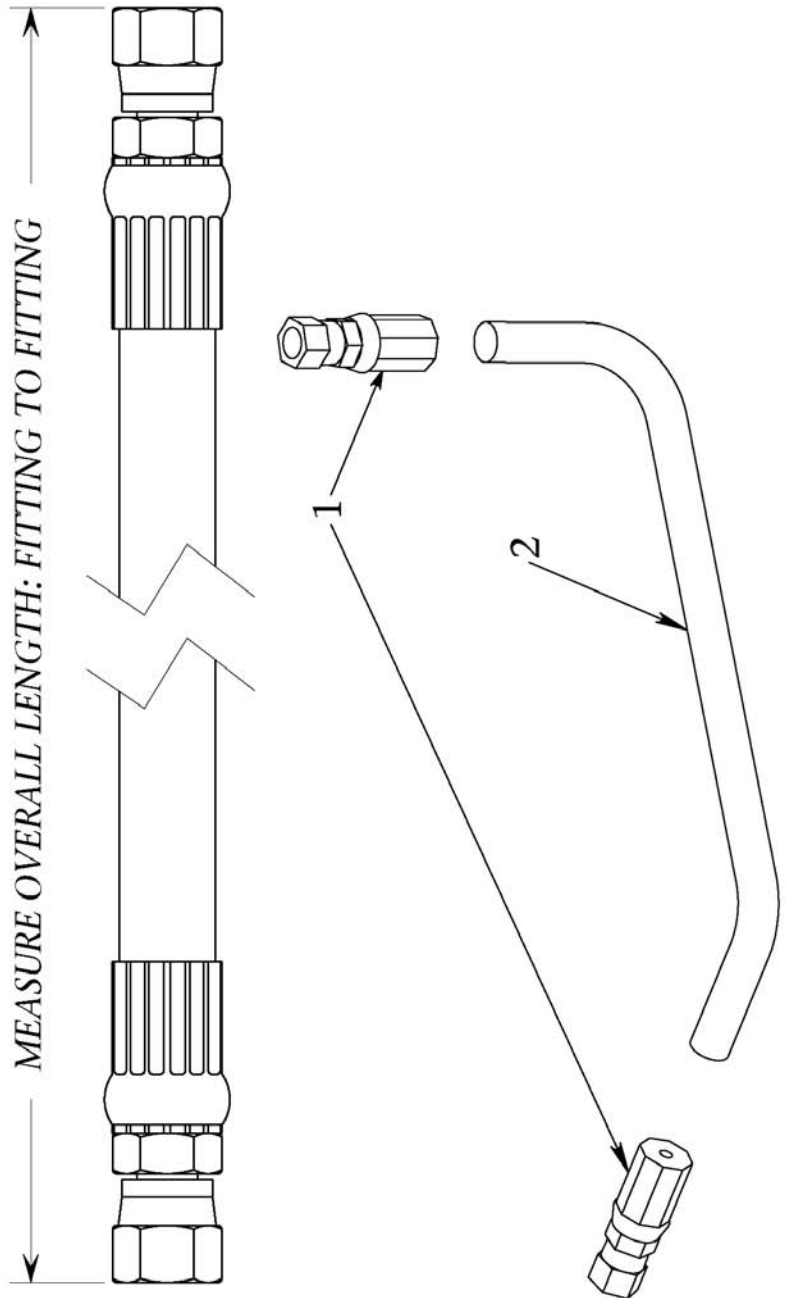

REVERSE OSMOSIS MEMBRANE & VESSEL ASSEMBLY SEAFARI 170

ITEM NO.	QTY.	U/M	PART NUMBER	DESCRIPTION
1 -- 20	1	EACH	B196220017	MEMBRANE VESSEL ASSY 170
1	1	EACH	2408132026	VESSEL 170 AW
2	1	EACH	2453497000	END PLUG 2 1/2" AW 170
3	1	EACH	2453487000	END PLUG SINGLE 2 1/2" AW 170
4	2	EACH	0117410801	HP NIPPLE, MVA, AW 170
5	2	EACH	0520210500	RETAINER PORT MVA AW 170
6	1	EACH	2020052407	PANEL MVA AW 170
7	2	EACH	05202402GR	BRACKET MVA U CLAMP AW 170
8	2	EACH	20201022000	SEGMENT RING AW 170
9	6	EACH	061162345010	SC SOC CAP 1/4-20 X 5/8 SS
10	1	EACH	1317010869	ELB90 -4 FLARE X 1/4 FPT SS
11	1	EACH	1317120869	CONN -4 FLARE X 1/4 FPT SS
12	8	EACH	061161845014	SC ALLEN FLAT 1/4-20 X 7/8 SS
13	4	EACH	061100043000	WASHER FLAT OS 1/4"SS
14	4	EACH	061060045000	NUT HEX 1/4-20 W/INSERT SS
15	4	EACH	2614017100	O-RING 111 SALINITY PRB/BPR CS
16	4	EACH	2614010100	O-RING 116 PRODUCT AS/AW
17	4	EACH	2614010200	O-RING 227 SEAL 2 1/2"
18	1	EACH	0204090869	CONN 1/4 TUBE X 1/4 MPT PLASTI
19	1	EACH	2724010633	MEMBRANE 2008SW AS W/ SEAL
20	1	EACH		BRINE SEAL 2 1/2 INCH

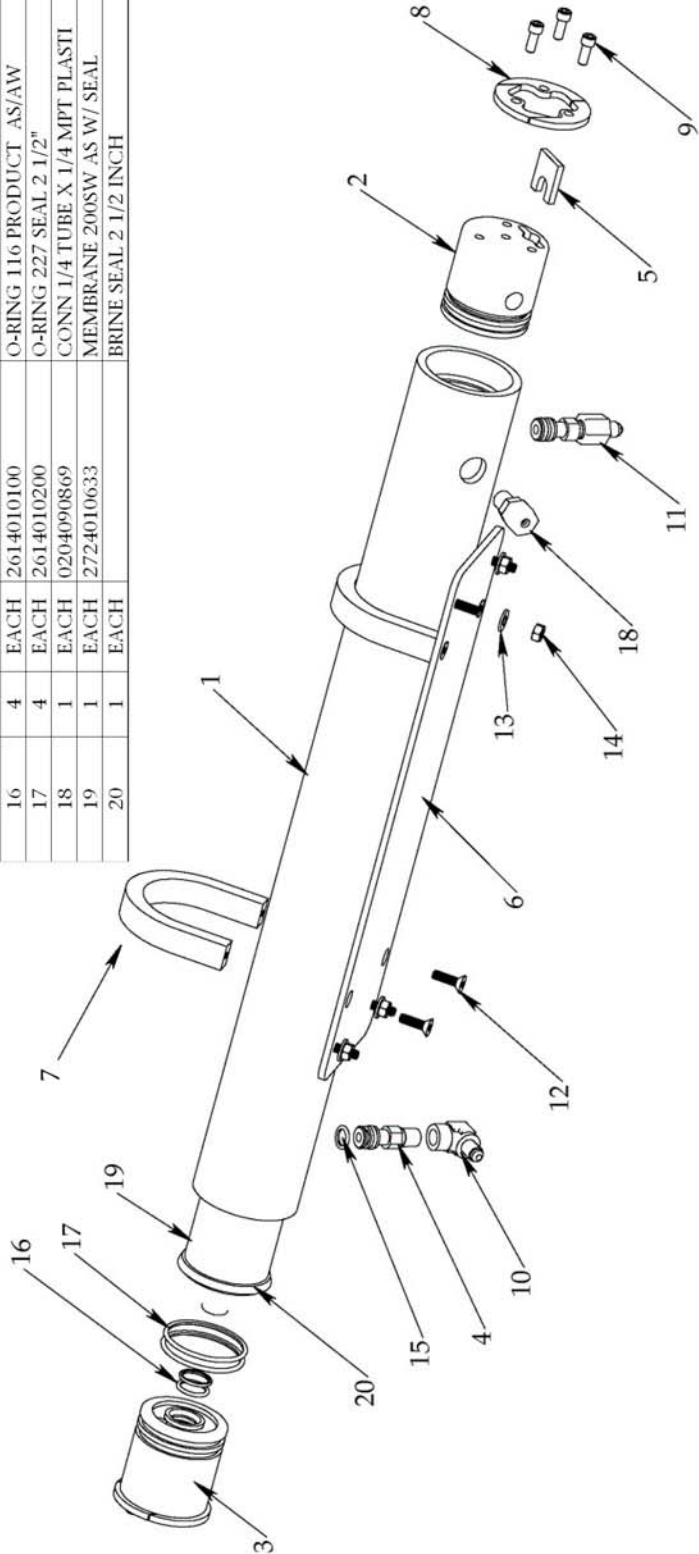

REVERSE OSMOSIS MEMBRANE & VESSEL ASSEMBLY SEAFARI 350

ITEM NO.	QTY.	U/M	PART NUMBER	DESCRIPTION
1 --	1	EACH	B196230001	MEMBRANE VESSEL ASSY 350
1	6	EACH	061162345012	SC.SOC CAP 1/4-20 X 3/4 SS
2	2	EACH	20201030000	SEGMENT RING AW (SET)
3	1	EACH	2453512400	END PLUG DUAL 3" AW
4	2	EACH	0520210600	RETAINER PORT MVA AW
5	4	EACH	2614014900	O-RING 230 BRINE 3" END PLUG
6	2	EACH	2614010100	O-RING 116 PRODUCT AS/AW
7	1	EACH	2724011233	MEMBRANE 400GPD AW W/ SEAL
8	1	EACH	2408132500	VESSEL HIGH PRESSURE 400GPD AW
9	1	EACH	2453502400	END PLUG SINGLE 3" AW
10	2	EACH	2614017900	O-RING 115 INTERCONNECT AW
11	1	EACH	0117410800	NIPPLE HP MVA AW
12	1	EACH	1317120869	CONN -4 FLARE X 1/4 FPT SS
13	1	EACH	1317010869	ELB90 -4 FLARE X 1/4 FPT SS
14	1	EACH	0101370815	NIPPLE 1/4 NPT X 1 1/2 PVC
15	1	EACH	0204010869	ELB90 1/4 TUBE X 1/4 FPT PLAST

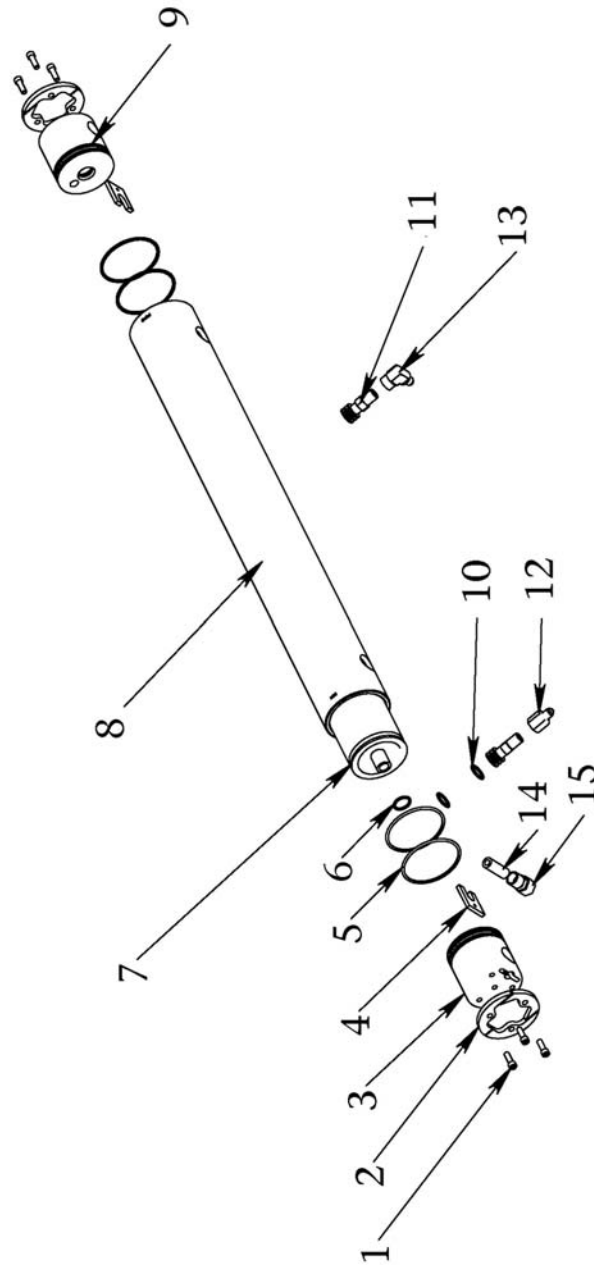

ANATOMY OF A SPIRAL WOUND REVERSE OSMOSIS MEMBRANE ELEMENT

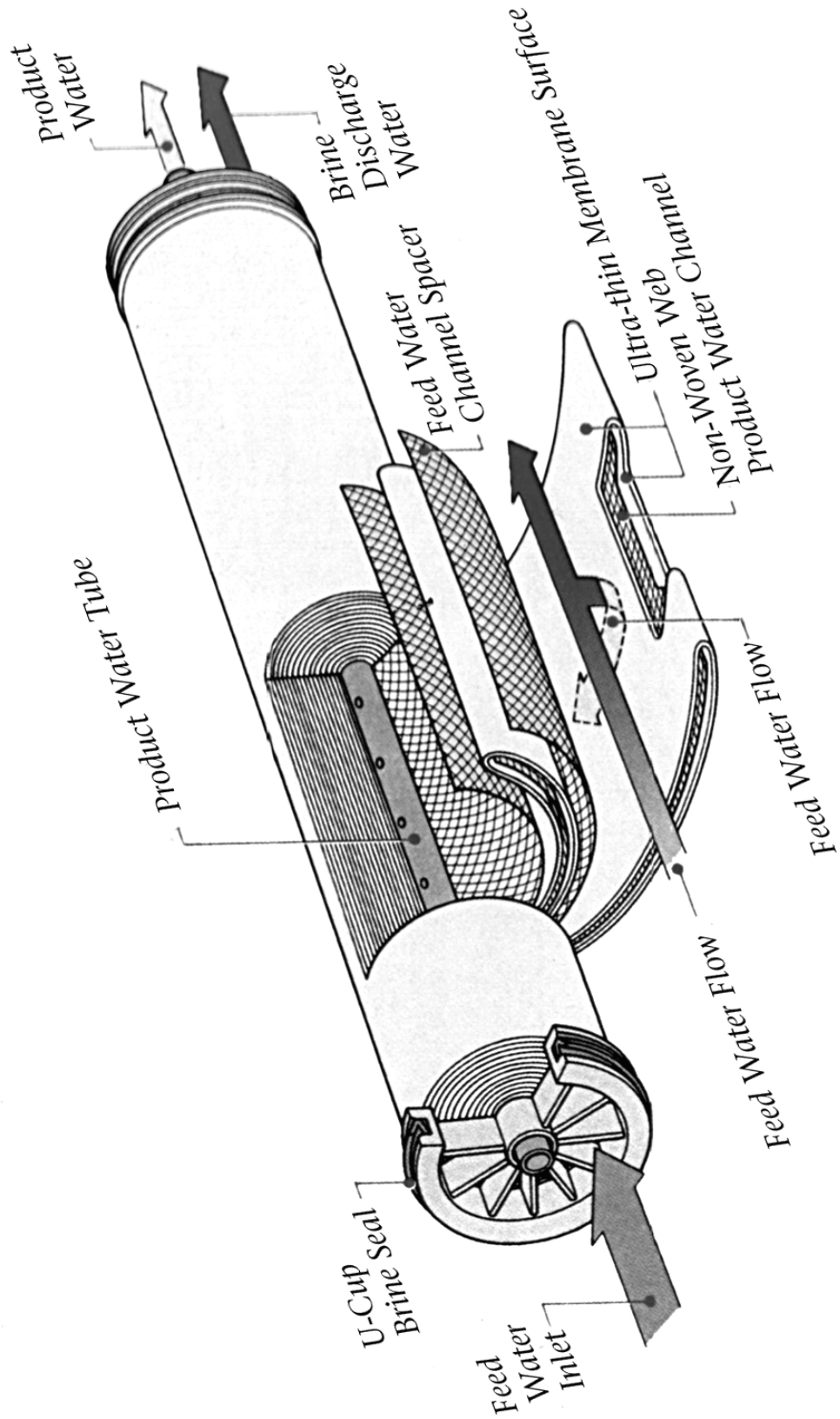

3-WAY PRODUCT WATER DIVERSION SOLENOID VALVE PORT DESIGNATION & DESCRIPTION (WATER FLOW)

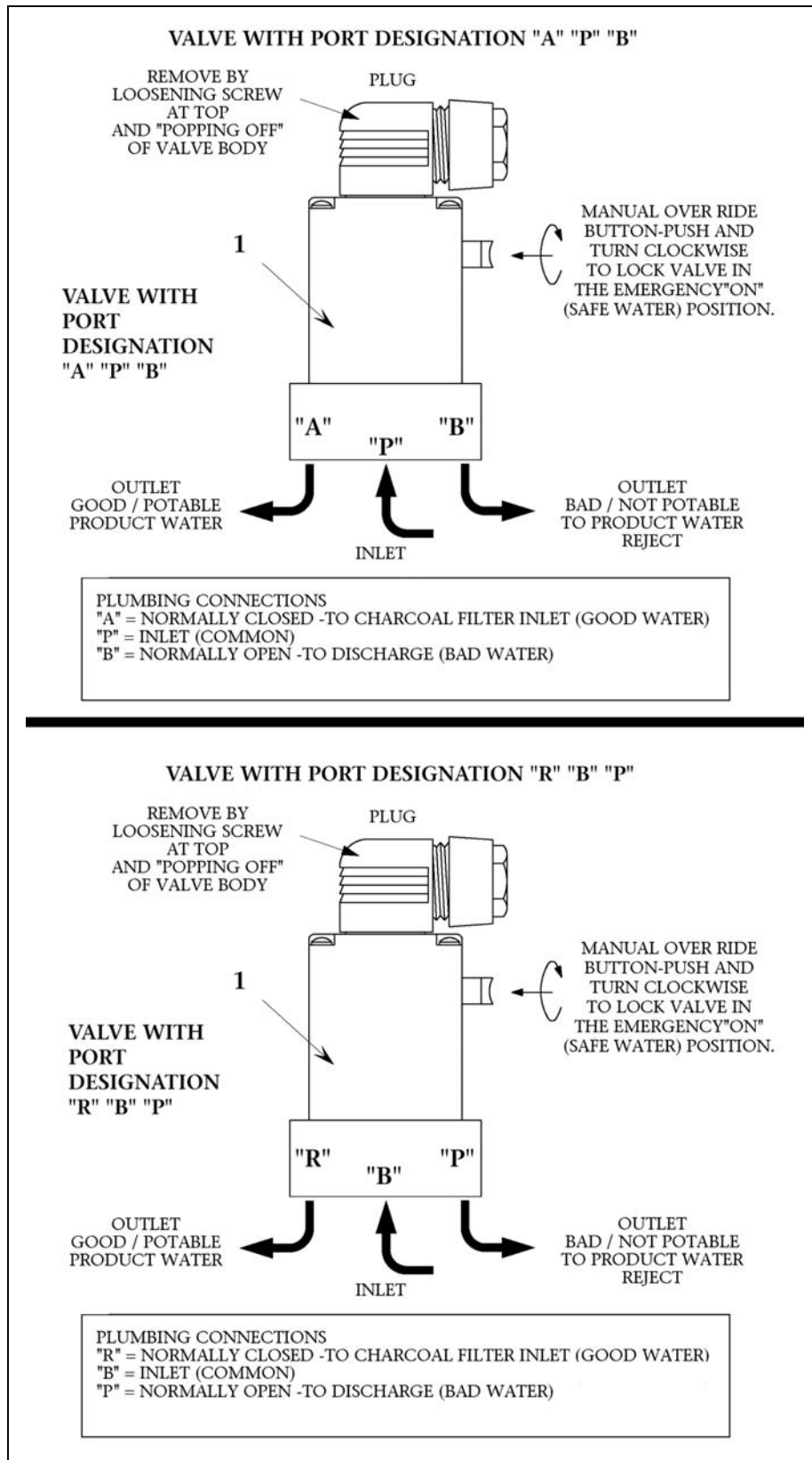

CONTROL MANIFOLD

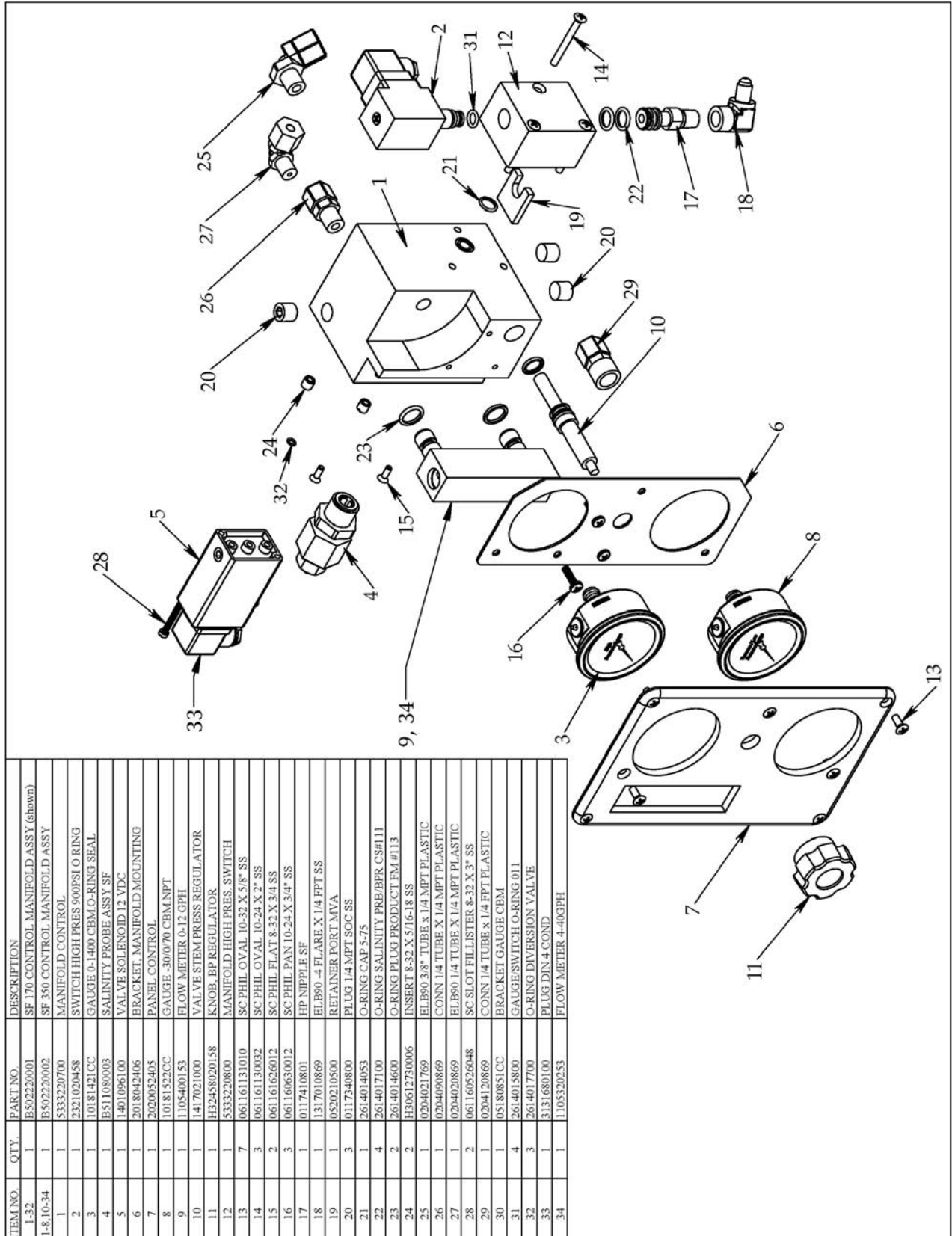

ITEM NO.	QTY.	PART NO.	DESCRIPTION
1-32	1	B502220001	SF 170 CONTROL MANIFOLD ASSY (shown)
1-8,10-34	1	B502220002	SF 350 CONTROL MANIFOLD ASSY
1	1	5333220700	MANIFOLD CONTROL
2	1	2321020458	SWITCH HIGH PRES 900PSI O RING
3	1	10181421CC	GAUGE 0-1400 CBM/O-RING SEAL
4	1	B511080003	SALINITY PROBE ASSY SF
5	1	1401096100	VALVE SOLENOID 12 VDC
6	1	2018042406	BRACKET, MANIFOLD MOUNTING
7	1	2020032405	PANEL CONTROL
8	1	10181522CC	GAUGE -300/70 CBM,NPT
9	1	1105400153	FLOW METER 0-12 GPH
10	1	1417021000	VALVE STEM PRESS REGULATOR
11	1	H32458020158	KNOB, BP REGULATOR
12	1	5333220800	MANIFOLD HIGH PRES. SWITCH
13	7	061161131010	SC PHIL OVAL 10-32 X 5/8" SS
14	3	061161130032	SC PHIL OVAL 10-24 X 2" SS
15	2	061161626012	SC PHIL FLAT 8-32 X 3/4 SS
16	3	061160630012	SC PHIL PAN 10-24 X 3/4" SS
17	1	0117410801	HP NIPPLE SF
18	1	1317010869	ELB90 -4 FLARE X 1/4 FPT SS
19	1	0520210500	RETAINER PORT MVA
20	3	0117340800	PLUG 1/4 NPT SOC SS
21	1	2614014053	O-RING CAP 5-75
22	4	2614017100	O-RING SALINITY PRB/BPR CS#11
23	2	2614014600	O-RING PLUG PRODUCT FM #113
24	2	H30612730006	INSERT 8-32 X 5/16-18 SS
25	1	0204021769	ELB90 3/8" TUBE X 1/4 MPT PLASTIC
26	1	0204090869	CONN 1/4 TUBE X 1/4 MPT PLASTIC
27	1	0204020869	ELB90 1/4 TUBE X 1/4 MPT PLASTIC
28	2	061160526048	SC SLOT FILLISTER 8-32 X 3" SS
29	1	0204120869	CONN 1/4 TUBE X 1/4 FPT PLASTIC
30	1	05180851CC	BRACKET GAUGE CBM
31	4	2614015800	GAUGE/SWITCH O-RING 011
32	3	2614017700	O-RING DIVERSION VALVE
33	1	3131680100	PLUG DIN 4 COND
34	1	1105320253	FLOW METER 4-40GPH

CLEAN / RINSE INLET VALVE

Clean/Rinse Inlet Valve

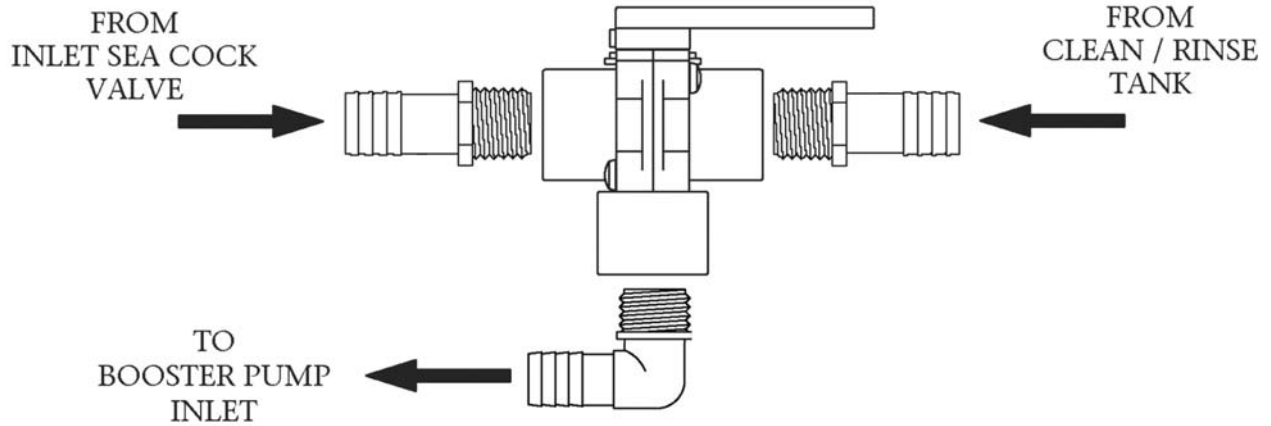

CLEAN / RINSE OUTLET VALVE

Clean/Rinse Outlet Valve

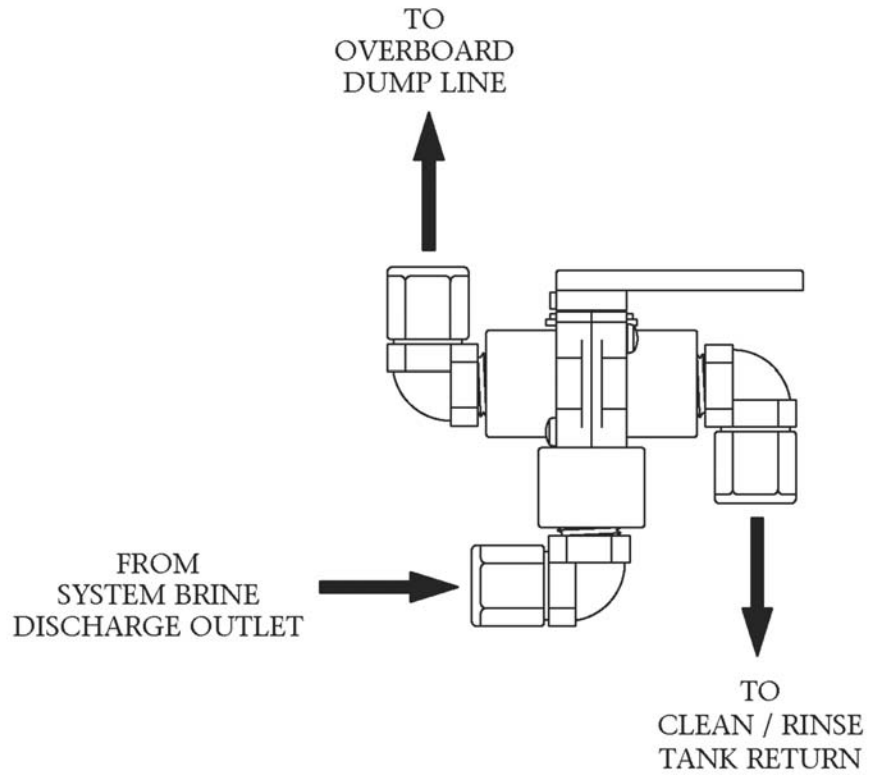

PRODUCT WATER POST FILTRATION CHARCOAL FILTER

ITEM NO.	QTY.	U/M	PART NUMBER	DESCRIPTION
1 -- 8	1	EACH	B521220002	CHARCOAL FILTER ASSY 170/350
1	1	EACH	0713020573	FILTER HOUSING/LID 3/8 X 10
1 & 2	1	EACH	2614010473	O-RING 237 BLUE HOUSING
3	1	EACH	0803004773	ELEMENT CHARCOAL 10"
4	2	EACH	0204020969	ELB90 1/4 TUBE X 3/8 MPT PLAST
5	1	EACH	20200402100	BRACKET PREFILTER/CHRC/L/PLNKTN
6	4	EACH	061170628016	SC PHIL PAN "A" 10 X 1 SS
7	4	EACH	061170628020	SC PHIL PAN "A" 10 X 1 1/4 SS
8	8	EACH	065080028000	WASHER FLAT #10 NYLON

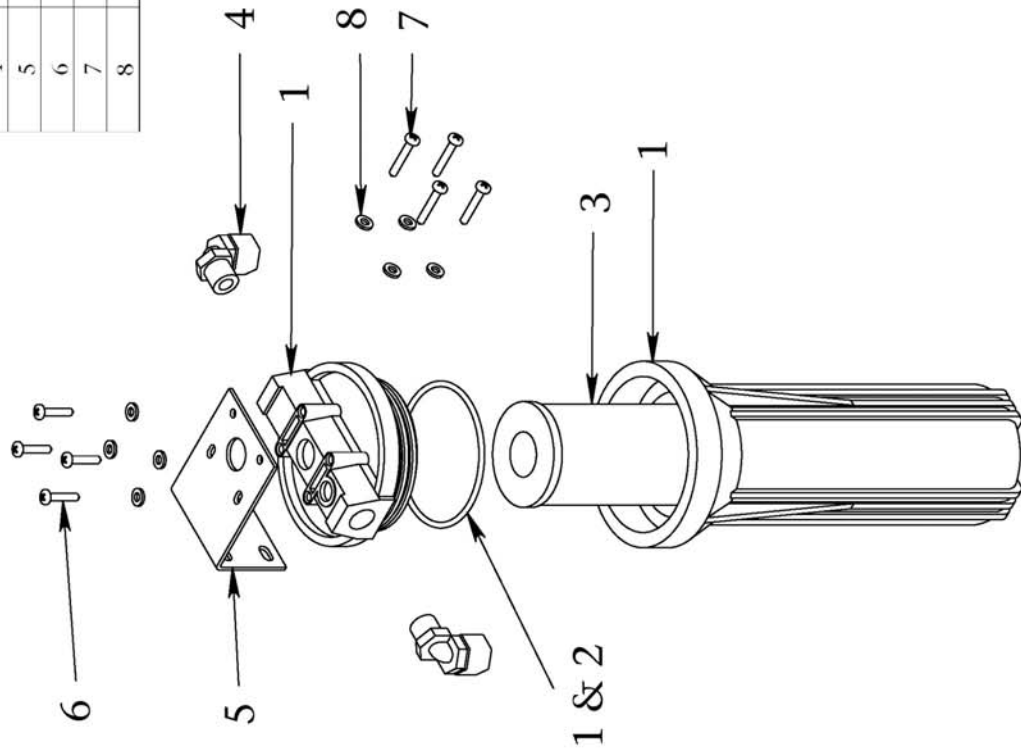

PRODUCT WATER pH NEUTRALIZER

ITEM NO.	QTY.	U/M	PART NUMBER	DESCRIPTION
1 -- 9	1	EACH	B561080002	PH NEUTRALIZER ASSY 0.5 GPM
1	1	EACH	0713020573	FILTER HOUSING/LID 3/8 X 10
1 & 2	1	EACH	2614010473	O-RING 237 BLUE HOUSING
3	1	EACH	08251950AS	ELEMENT PH 9 3/4"
4	2	EACH	0204020969	ELB90 1/4 TUBE X 3/8 MPT PLAST
5	1	EACH	20200402100	BRACKET PREFILTER/CHRLCL/PLNKTN
6	4	EACH	065080028000	WASHER FLAT #10 NYLON
7	4	EACH	061170628016	SC PHIL PAN "A" 10 X 1 SS
8	4	EACH	061100043000	WASHER FLAT OS 1/4"SS
9	4	EACH	061172143016	SC HEX "A" 1/4 X 1 SS

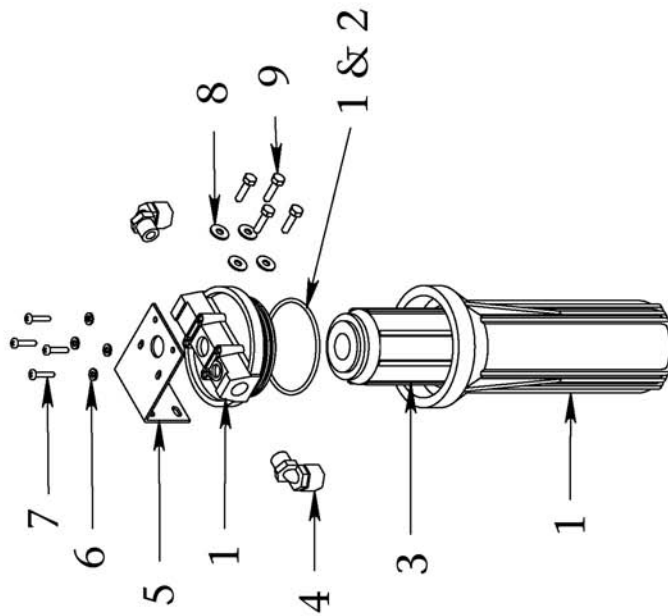

PRODUCT WATER ULTRA VIOLET STERILIZER

ITEM NO.	QTY.	PART NUMBER	DESCRIPTION
1-22	1	B52680000B	UV Sterilizer Assy
1	1	4000160100	Cap Electrical
2	1	1904010643	Strain Relief 3444
3	1	4000021400	Ballast 12 VDC
4	1	4000100200	Bushing Top End
5	2	2614019000	O-Ring 212 Seal
6	1	2401532200	End Plug Top
7	4	2614010200	O-Ring 227 2 1/2"
8	1	4000010400	Lamp UV
9	1	4000040400	Quartz Sleeve
10	1	2417202200	Vessel
11	1	2401522200	End Plug Bottom
12	1	4000100300	Bushing Bottom
13	2	20010418002A	Bottom Mounting Saddle
14	4	061160630048	SC Phil Pan 10-24 x 3 SS
15	2	20010418001A	Top Mounting Saddle
16	6	061162345004	SC Soc Cap 1/4-20 x 1/4 SS
17	2	061160630008	SC Phil Pan 10-24 x 1/2 SS
18	2	061142145020	Bolt Hex 1/4-20 x 1 1/4 SS
19	2	061100043000	Washer Flat OS 1/4 SS
20	6	061161130016	SC Phil Oval 10-24 x 1 SS
21	2	0204020869	Elbow 90 1/4" Tube x 1/4" MT Plastic
22	1	061161130020	SC Phil Oval 10-24 x 1 1/4 SS

The diagram shows an exploded view of the UV Sterilizer Assembly. It includes a main cylindrical vessel (10) with a top end cap (1) and a bottom end cap (11). A UV lamp (8) is mounted inside the vessel, protected by a quartz sleeve (9). The lamp is secured by a top mounting saddle (15) and a bottom mounting saddle (13). Various nuts, washers, and screws (16-19) are used to secure the saddles and the lamp assembly. A ballast (3) and electrical cap (1) are connected to the assembly. The entire unit is supported by a frame (10) with mounting brackets (13, 14, 15) and is connected to a tube (21) via an elbow (21). The assembly is shown in an exploded view to illustrate the relationship between the parts.

FRESH WATER FLUSH

ITEM NO.	QTY.	U/M	PART NUMBER	DESCRIPTION	ITEM NO.	QTY.	U/M	PART NUMBER	DESCRIPTION
1	EACH		B598000002	FRESH WATER FLUSH -> 12/00	19	3	EACH	0204092069	CONN 3/8 TUBE X 3/4 MPT PLASTI
2	EACH		1401095998	VALVE SOLENOID 12VDC AED/CSFE/	19	1	EACH	0204022069	ELB90 3/8 TUBE X 3/4 MPT PLAST
3	EACH		0101340883	PLUG 1/4 MPT PVC	20	1	EACH	0101423783	TEE 3/4 FT X 3/4 FT X 3/4 FT P
4	FEET		4942220811	WIRE 18 GA 2 COND. ORANGE FLEX	21	1	EACH	01013737CL	NIPPLE 3/4 NPT X CLOSE PVC
5	EACH		2020040001	BRACKET CARBON FILTER HSG FWF	22	1	EACH	14012118AR	VALVE CHECK 3/4" FPT WITH VITO
6	EACH		065080028000	WASHER FLAT #10 NYLON	23	2	EACH	0101653783	ADAP 3/4 MPT X 3/4 BARR PVC
7	EACH		061170628016	SC PHIL PAN "A" 10 X 1 SS	23	2	EACH	0112653600	ADAP 3/4 MPT X 1/2 BARR NYLON
8	EACH		065080023000	WASHER FLAT #8 NYLON	24	4	EACH	05181434AA	HOSE CLAMP 3/4" SS
9	EACH		061161626012	SC PHIL FLAT 8-32 X 3/4 SS	25	2	EACH	0501164500	PIPE SUPPORT 1 1/4"
10	EACH		0204091769	CONN 3/8 TUBE X 1/4 MPT PLASTI	26	2	EACH	061060026000	NUT HEX 8-32 W/INSERT SS
11	FEET		0312123569	TUBE 3/8 BLACK	27	2	EACH		SC FLAT 8-32 X 3/4
12	EACH		0204021769	ELB90 3/8 TUBE X 1/4 MPT PLAST	28	1	EACH	20200040002	BRACKET CHECK VALVE FWF
13	EACH		0101010883	ELB90 1/4 FPT X 1/4 FPT PVC	29	1	EACH	0713020606-3	FILTER LID WRENCH/BIG BLUE
14	EACH		14172105AT	VALVE CHECK 1/4" MPT SS		4	EACH	061170623008	SC PHIL PAN "B" 8 X 1/2 SS
15	EACH		0101293483	RB 3/4 MT X 1/4 FT PVC		4	EACH	061172143016	SC HEX "A" 1/4 X 1 SS
16	EACH		0101294383	RB 1 MT X 3/4 FT PVC		4	EACH	061100043000	WASHER FLAT OS 1/4"SS
16 & 17	EACH		0713020606	FILTER HOUSING BIG BLUE		4	EACH	061172149020	SC HEX "A" 5/16 X 1 1/4 SS
18	EACH		2614010500	O-RING 357 BIG BLUE HOUSING		4	EACH	061100049000	WASHER FLAT OS 5/16"SS
			0803004906	ELEMENT CARBON BRIQUETTE 10"					

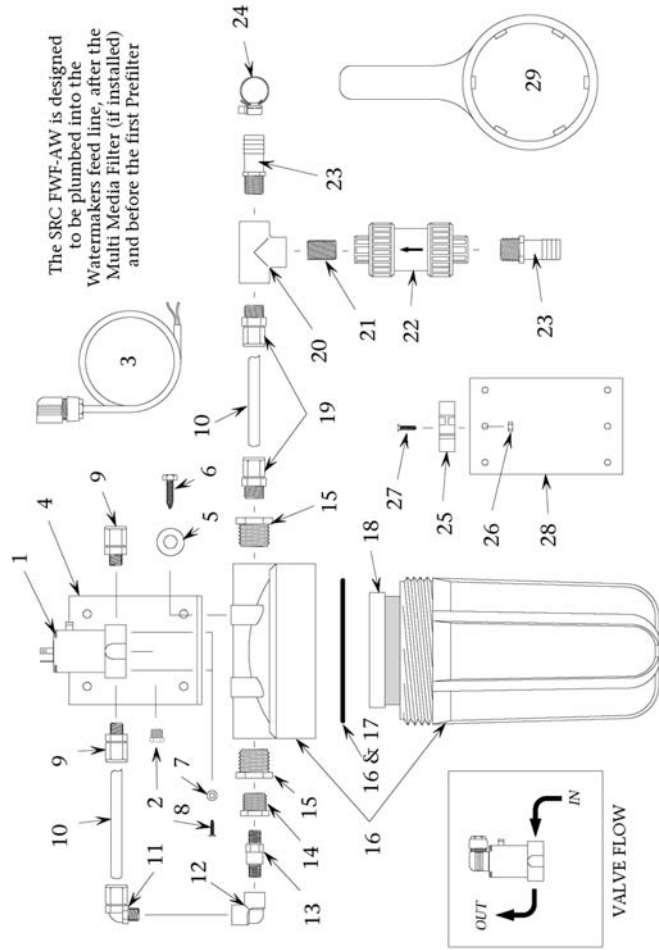

ELECTRICAL CONTROLLER SEAFARI 170 12 VDC & 24 VDC

ITEM NO.	QTY.	U/M	PART NUMBER	DESCRIPTION
1 -- 6	1	EACH	B595220012	CONTROLLER 170 12 VDC
1 -- 7	1	EACH	B595220024	CONTROLLER 170 24 VDC
1	1	EACH	31312222AB	ENCLOSURE AW 170
2	1	EACH	3131232200	CHASSIS PLATE AW 170
3	1	EACH	B596800009	PCB MAIN -UNIVERSAL W/ HR METE
4	2	EACH	3131110600	RELAY 1 FORM A (1PST-N.O.) 12V
5	1	EACH	3131222300	ENCLOSURE LID 170 UW/SE
6	2	EACH	26351500AB	GASKET ENCLOSURE - AS
	1	EACH	B511080003	SALINITY PROBE ASSY 2002
	1	EACH	31314203HA	SALINITY PROBE W/ TEMP SENSOR
7	1	EACH	B596220020	PCB STEPDOWN AW 170

ELECTRICAL CONTROLLER SEAFARI 170 & 350 110/220 VAC

ITEM NO.	QTY.	U/M	PART NUMBER	DESCRIPTION
	1	EACH	B595220007	CONTROLLER 170 & 350 110/220 VAC
1	1	EACH	31314301CW	POWER SUPPLY AW>12/99 12VDC
2	1	EACH	B596800009	PCB MAIN -UNIVERSAL W/ HR METE
3	1	EACH	31312222AB	ENCLOSURE AW 170
4	1	EACH	3131232200	CHASSIS PLATE AW 170
5	1	EACH	3131222300	ENCLOSURE LID 170 UW/SE
6	2	EACH	26351500AB	GASKET ENCLOSURE - AS
	1	EACH	B511080003	SALINITY PROBE ASSY 2002
	1	EACH	31314203HA	SALINITY PROBE W/ TEMP SENSOR

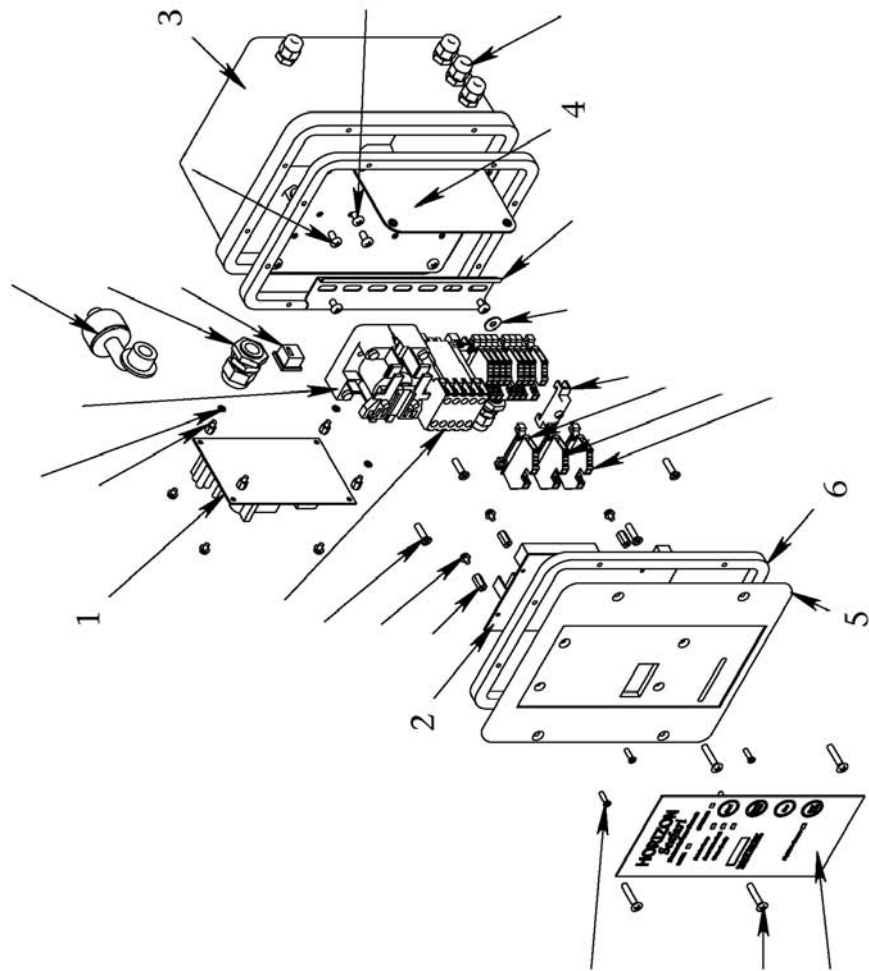

ELECTRONIC CONTROL PRINTED CIRCUIT BOARD

LED INDICATIONS FRESH WATER FLUSH TIMING ADJUSTMENT POINT SALINITY CALIBRATION ADJUSTMENT POINT

