



USERS MANUAL / GEBRUIKERSHANDLEIDING / BETRIEBSANLEITUNG
MANUEL UTILISATEUR / MANUAL DE UTILIZACION / INSTRUZIONI PER L'USO

CHARGEMASTER

12/70-3, 12/100-3, 24/40-3, 24/60-3, 24/80-3 & 24/100-3

FULL AUTOMATIC BATTERY CHARGER



MASTERVOLT
Snijdersbergweg 93,
1105 AN Amsterdam
The Netherlands
Tel.: +31-20-3422100
Fax.: +31-20-6971006
www.mastervolt.com



ENGLISH:	PAGE 1
NEDERLANDS:	PAGINA 37
DEUTSCH:	SEITE 73
FRANÇAIS:	PAGINA 109
CASTELLANO:	PÁGINA 145
ITALIANO:	PÁGINA 181

v 1.1 August 2007

CONTENTS:

v 1.1 August 2007

1	GENERAL INFORMATION.....	5
1.1	Use of this manual.....	5
1.2	Validity of this manual	5
1.3	Use of pictograms	5
1.4	Identification label.....	5
1.5	Liability	5
2	IMPORTANT SAFETY INSTRUCTIONS	6
2.1	General	6
2.2	Explosive gases	6
2.3	Warnings regarding the use of batteries.....	7
2.4	Warning regarding life support applications.....	7
2.5	Guarantee specifications	7
3	OPERATION	8
3.1	Features	8
3.2	Switching on / stand-by	8
3.3	LCD-display.....	9
3.4	Three Step charge algorithm.....	10
3.4.1	Temperature compensated charging.....	10
3.4.2	Connection of a second and third battery.....	10
3.5	Historical data.....	11
3.6	Masterbus (optional).....	12
3.7	Maintenance.....	12
3.8	Failures.....	12
4	INSTALLATION	13
4.1	Unpacking	13
4.2	Environment	13
4.3	Wiring	13
4.3.1	AC-wiring.....	13
4.3.2	DC wiring.....	14
4.3.3	Battery capacity.....	14
4.3.4	AC safety grounding.....	14
4.4	Overview connection compartment	15
4.5	Things you need.....	16
4.6	Connection	16
4.7	Installation step-by-step	18
4.8	Commissioning after installation.....	20
4.8.1	General.....	20
4.8.2	MasterBus (optional)	20
4.9	Decommissioning	20
4.10	Storage and transportation	20
4.11	Re-installation.....	20

5	SETTINGS	21
5.1	DIP Switch settings	21
5.1.1	DIP-switch 1: Battery type	21
5.1.2	DIP switch 2: Charge algorithm	21
5.1.3	DIP-switch 3:Stand-by mode for display.....	21
5.1.4	DIP switch 4: Equalize mode.....	21
5.2	Settings at the LCD-display	22
5.2.1	Settings menu for models 12/70-3 and 12/100-3.....	22
5.2.2	Settings menu for models 24/40-3, 24/60-3, 24/80-3 and 24/100-3	23
6	MASTERBUS	24
6.1	What is MasterBus?	24
6.2	How to set up a MasterBus network.....	25
6.3	MasterBus: Monitoring and Programming of the ChargeMaster.....	26
6.3.1	Level 2: Monitoring	26
6.3.2	Level 3: Alarms.....	26
6.3.3	Level 3: History.....	26
6.3.4	Level 3: Configuration.....	27
6.3.5	List of list of events sources	28
6.3.6	List of list of event commands	28
7	TROUBLE SHOOTING	29
7.1	Fault finding table	29
7.2	Fault indication	29
8	TECHNICAL DATA	30
8.1	Specifications 12V models	30
8.2	Specifications 24V models	31
8.3	Characteristics.....	32
9	ORDERING INFORMATION	34
9.1	MasterBus installation components.....	34
9.2	Miscellaneous.....	34
10	EC DECLARATION OF CONFORMITY	35

1 GENERAL INFORMATION

1.1 USE OF THIS MANUAL

This manual contains important safety and operating instructions for the safe and effective operation, maintenance and possible correction of minor malfunctions of the Chargemaster.

It is therefore obligatory that every person who works on or with the Chargemaster must be completely familiar with the contents of this manual, and that he/she carefully follows the instructions and important safety instructions contained herein.

The English version has 36 pages.

1.2 VALIDITY OF THIS MANUAL

All of the specifications, provisions and instructions contained in this manual apply solely to standard versions of the Chargemaster delivered by Mastervolt.

This manual is valid for the following models:

Part number	Model
44010700	Chargemaster 12/70-3
44011000	Chargemaster 12/100-3
44020400	Chargemaster 24/40-3
44020600	Chargemaster 24/60-3
44020800	Chargemaster 24/80-3
44021000	Chargemaster 24/100-3

These models are further mentioned as "Chargemaster" For other models see other manuals available on our website: www.mastervolt.com

1.3 USE OF PICTOGRAMS

Safety instructions and warnings are marked in this manual by the following pictograms:



WARNING

A WARNING refers to possible injury to the user or significant material damage to the charger if the user does not (carefully) follow the procedures.



CAUTION!

Special data, restrictions and rules with regard to preventing damage.



A procedure, circumstance, etc which deserves extra attention.

1.4 IDENTIFICATION LABEL

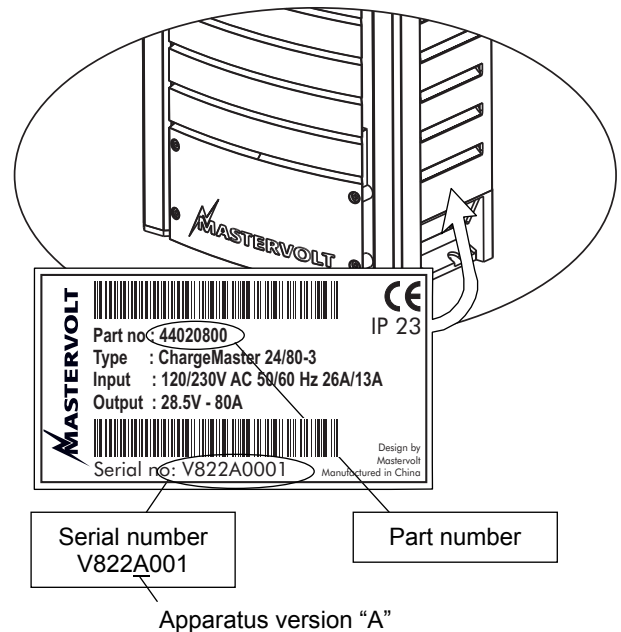

Figure 1: Identification label

The identification label is located at the right-hand side of the Chargemaster. (see figure 1) Important technical information required for service, maintenance & secondary delivery of parts can be derived from the identification label.



CAUTION!

Never remove the identification label.

1.5 LIABILITY

Mastervolt can accept no liability for:

- consequential damage due to use of the Chargemaster;
- possible errors in the manuals and the results thereof.

2 IMPORTANT SAFETY INSTRUCTIONS

READ AND SAVE THESE INSTRUCTIONS



WARNING

This chapter describes important safety and operating instructions for use of a Chargemaster in residential, recreational vehicle (RV) and marine applications.

2.1 GENERAL

- 1 Before using the Chargemaster, read all instructions and cautionary markings on the Chargemaster, the batteries, and all appropriate sections of the manual.
- 2 To reduce the risk of electric shock – Do not expose Chargemaster to rain, snow, spray, moisture, excessive pollution and condensing circumstances. To reduce risk of fire hazard, do not cover or obstruct the ventilation openings. Do not install the Chargemaster in a non-ventilated room, overheating may result.
- 3 Use of an attachment or spare part not recommended or sold by Mastervolt may result in a risk of fire, electric shock, or injury to persons.
- 4 The Chargemaster is designed to be permanently connected to an AC and DC electrical system. Installation of, and work on the Chargemaster, may be carried out only by a qualified, authorised and trained technician or electrician, consistent with the locally applicable standards and regulations.
- 5 Make sure that all wiring is properly installed and in good electrical condition; and that wire size is large enough for AC ampere rating of the Chargemaster. Check the wiring on a regular base, at least once a year. Do not use the Chargemaster when the wiring is undersized or damaged.
- 6 Do not operate Chargemaster if it has received a sharp blow, been dropped, or otherwise damaged in any way; take it to a qualified serviceman.
- 7 Except for the connection compartment, see chapter 4, the Chargemaster may not be opened or disassembled. There are no serviceable parts inside the cabinet. Take it to a qualified, authorized and trained serviceman when service or repair is required. Incorrect reassembly may result in a risk of electric shock or fire. Only qualified, electrician installers are authorized to open the connection compartment.
- 8 To reduce risk of electric shock, disconnect the Chargemaster from both AC and DC electrical system before attempting any maintenance or cleaning. Turning off controls will not reduce this risk.
- 9 The Chargemaster must be provided with an equipment-grounding conductor to the AC-input ground terminal. Grounding and all other wiring must comply with local codes and ordinances.
- 10 Short circuiting or reversing polarity will lead to serious damage to batteries, Chargemaster, wiring as well as accessories. Fuses can not prevent damage caused by reversed polarity and the warranty will be void.
- 11 In case of fire, you must use the fire extinguisher which is appropriate for electrical equipment.
- 12 If applied in a marine application in the United States, external connections to the Chargemaster shall comply with the United States Coast Guard Electrical Regulations (33CFR183, Sub part I).

2.2 EXPLOSIVE GASES

- 1 **WARNING – RISK OF EXPLOSIVE GASES. WORKING IN VICINITY OF A LEAD-ACID BATTERY IS DANGEROUS. BATTERIES GENERATE EXPLOSIVE GASES DURING NORMAL BATTERY OPERATION. FOR THIS REASON, IT IS OF UTMOST IMPORTANCE THAT EACH TIME BEFORE USING THE CHARGEMASTER, YOU READ THIS MANUAL AND FOLLOW THE INSTRUCTIONS EXACTLY.**
- 2 To reduce risk of battery explosion, follow these instructions and those published by battery manufacturer and manufacturer of any equipment you intend to use in vicinity of the battery. Review cautionary marking on these products.
- 3 **DANGER:** To reduce the risk of explosion – Never use the Chargemaster in situations where there is danger of gas or dust explosion or area in which ignition-protected equipment is required.

2.3 WARNINGS REGARDING THE USE OF BATTERIES

- 1 Someone should be within range of your voice or close enough to come to your aid when you work near a lead-acid battery.
- 2 Have plenty of fresh water and soap nearby in case battery acid contacts skin, clothing, or eyes.
- 3 Wear complete eye protection and clothing protection. Avoid touching eyes while working near battery.
- 4 If battery acid contacts skin or clothing, wash immediately with soap and water. If acid enters eye, immediately flood eye with running cold water for at least 10 minutes and get medical attention immediately.
- 5 NEVER smoke or allow a spark or flame in vicinity of battery or engine.
- 6 Do not short circuit batteries, as this may result in explosion and fire hazard! Be extra cautious to reduce risk of dropping a metal tool onto battery. It might spark or short-circuit battery or other electrical part that may cause explosion.
- 7 Remove personal metal items such as rings, bracelets, necklaces, and watches when working with a lead-acid battery. A lead-acid battery can produce a short-circuit current high enough to weld a ring or the like to metal, causing a severe burn.
- 8 Only use Chargemaster for charging a LEAD-ACID batteries and the supply of users attached to these batteries, in permanent systems. Do not use Chargemaster for charging dry-cell batteries that are commonly used with home appliances. These batteries may burst and cause injury to persons and damage to property.
- 9 NEVER charge a frozen battery.
- 10 Excessive battery discharge and/or high charging voltages can cause serious damage to batteries. Do not exceed the recommended limits of discharge level of your batteries.
- 11 If it is necessary to remove a battery, always remove grounded terminal from battery first. Make sure all accessories are off, so as not to cause an arc.

- 12 Be sure that the area around battery is well ventilated while battery is being charged. Refer to the recommendations of the battery manufacturer.
- 13 Batteries are heavy! It may become a projectile if it is involved in an accident! Ensure adequate and secure mounting and always use suitable handling equipment for transportation.

2.4 WARNING REGARDING LIFE SUPPORT APPLICATIONS

The Chargemaster is not sold for applications in any medical equipment intended for use as a component of any life support system unless a specific written agreement pertaining to such intended use is executed between the manufacturer and Mastervolt. Such agreement will require the equipment manufacturer either to contract additional reliability testing of the Chargemaster and/or to commit to undertake such testing as a part of the manufacturing process. In addition the manufacturer must agree to indemnify and not hold Mastervolt responsible for any claims arising from the use of the Chargemaster in the life support equipment.

2.5 GUARANTEE SPECIFICATIONS

Mastervolt guarantees that this unit has been built according to the legally applicable standards and specifications. Should work take place, which is not in accordance with the guidelines, instructions and specifications contained in this users manual, then damage may occur and/or the unit may not fulfil its specifications. All of these matters may mean that the guarantee becomes invalid.

The guarantee is limited to the costs of repair and/or replacement of the product. Costs for installation labor or shipping of the defective parts are not covered by this guarantee.

3 OPERATION

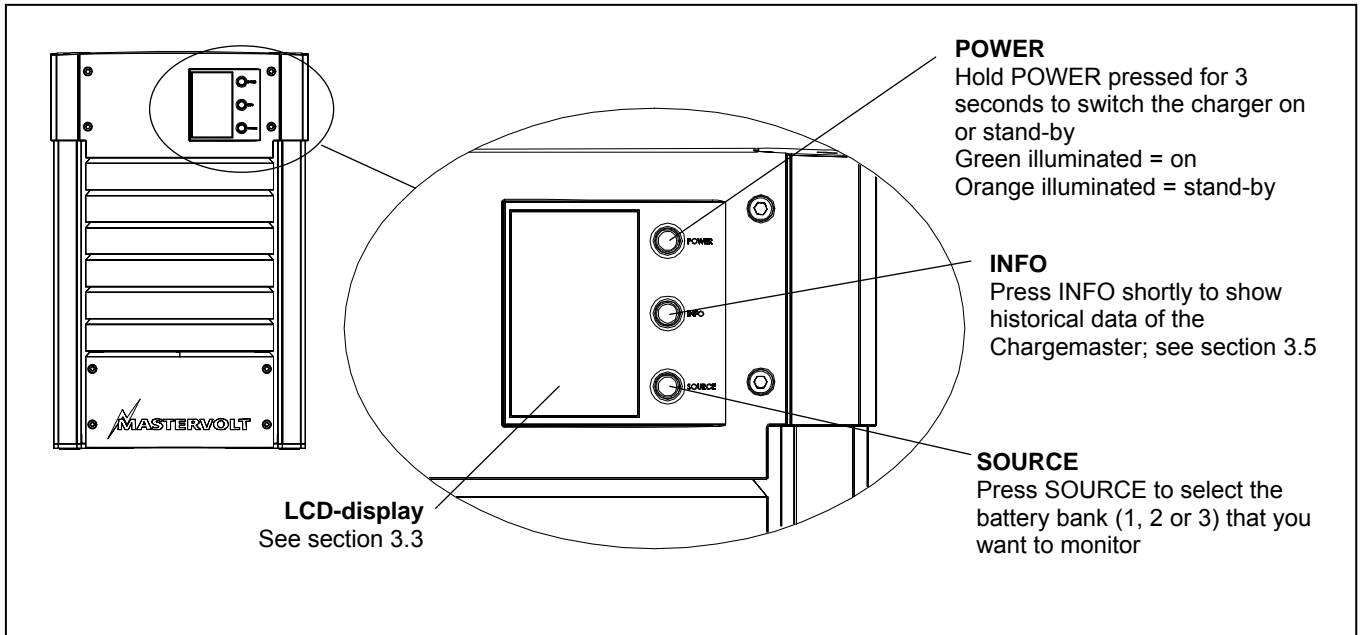

Figure 2: operation of the Chargemaster

3.1 FEATURES

The Mastervolt Chargemaster is a fully automatic battery charger. This means that under normal circumstances it may stay switched on with the AC power and batteries connected. The Chargemaster is suitable for charging of lead-acid batteries which may include maintenance-free, low maintenance, AGM/spiral, gel or deep-cycle batteries. It has an auto-ranging input facility which makes it feasible to operate on almost any AC power source in the world. It operates smoothly on both 230V as well as on 120V without any compromises for the output current. The three-step Plus charging method guarantees that the batteries are always charged to 100%.

With an external AC source connected, the Chargemaster charger also serves the functions of an AC to DC converter to supply DC loads which are connected to the batteries.

3.2 SWITCHING ON / STAND-BY

The Chargemaster is activated by holding the POWER switch pressed for approx. 3 seconds. The POWER switch will illuminate green. After switching on, the installed software version is shown for 10 seconds. The state of charge (which is stored in the memory of the Chargemaster) will be displayed. If necessary and if AC power is available, the Chargemaster will start to charge the batteries.

By holding the POWER switch pressed again for approx. 3 seconds, the Chargemaster will switch back to stand-by: the Chargemaster stops and the POWER switch illuminates orange.



WARNING

Switching the Chargemaster to “stand-by” does not cut off the connection to the batteries or the AC-source. This means that voltages are still available inside the apparatus.

If the Chargemaster was switched to stand-by or AC power became unavailable, the POWER switch starts to blink orange. After approximately 2 minutes the blinking will stop and the display will switch off, so that the batteries will not be loaded by the indication light.



Only if DIP-switch #3 was adjusted to ON *and* the charger was switched on, the indication light stays blinking orange, indicating that the AC-power supply fails in operation. Note that this blinking LED may slowly drain your batteries.

3.3 LCD-DISPLAY

The display at the front side of the Chargemaster enables you to monitor the charging process. See figure 3.



If no switch is touched during 20 seconds, the display will go to the initial readings, showing the charge voltage and charge current.

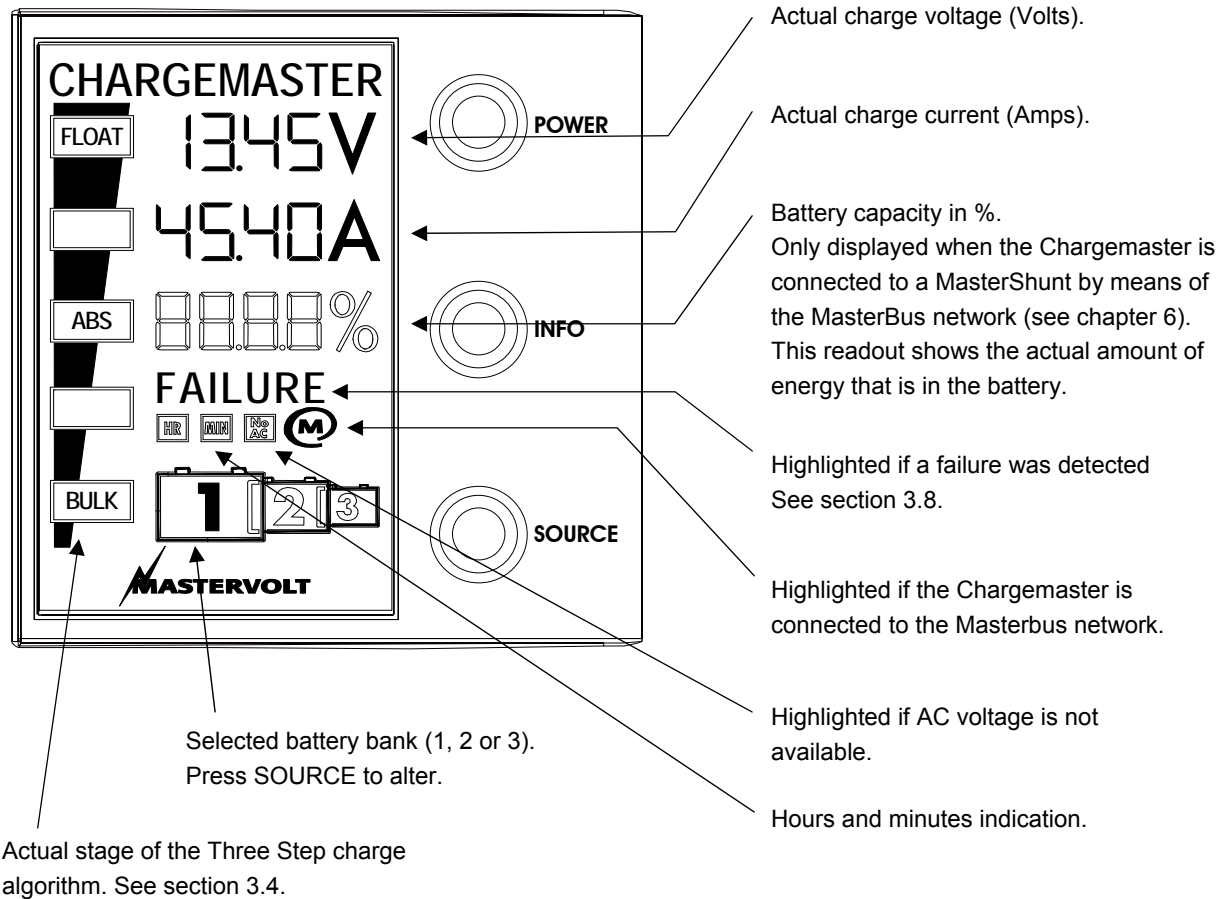

Figure 3: Initial readings at the LCD-display (displayed values may differ)

3.4 THREE STEP CHARGE ALGORITHM

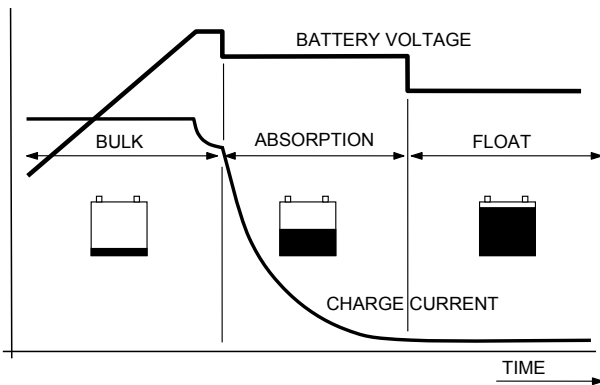

Figure 4: Three step Plus charge system

See figure 4. Battery charging is accomplished in three automatic stages: BULK, ABSORPTION and FLOAT.

The first step of the three step Plus charge system is the BULK phase, in which the output current of the charger is 100%, and the greater part of the capacity of the battery is rapidly charged. The current charges the batteries and gradually the voltage rises to the absorption voltage of 14.4V (12V models) or 28.8V (24V models) at 25°C / 77°F. The duration of this phase depends on the ratio of battery to charger capacity, and also on the degree to which the batteries were discharged to begin with.

The bulk phase is followed by the ABSORPTION phase. Absorption charging starts when the voltage on the batteries has reached 14.4V (12V models) / 28.8V (24V models) at 25°C / 77°F, and ends when the battery is completely full. Battery voltage remains constant at 14.25V (12V models) / 28.5V (24V models) at 25°C / 77°F throughout this stage, and the charge current depends on the degree to which the battery was initially discharged, the battery type, the ambient temperature, and so on. With a wet cell battery this stage lasts some four hours, with gel and AGM around three. Once the battery is 100% full, the Chargemaster automatically switches over to the float phase.

During the FLOAT phase the Chargemaster switches to 13.25V (12V models) or 26.5V (24V models) at 25°C / 77°F and stabilises this voltage to maintain the batteries in an optimum condition. Connected DC-loads are powered directly by the charger. If the load is higher than charger capacity, the required additional power comes from the battery, which will be progressively discharged until the charger automatically switches back to the bulk phase. Once consumption decreases, the charger goes back to normal operation of the three-step charge system.

As the Chargemaster is equipped with a three-step Plus charge system, the batteries can also remain connected to the Chargemaster in winter. One hour every 12 days the charger automatically switches to absorption to keep the battery running properly and prolong its life span. The three-step Plus charge system is also safe for all the connected equipment.



See also section 8.3 for detailed characteristics of the three step Plus charge system.

3.4.1 Temperature compensated charging

By installing the battery temperature sensor the charge voltages are automatically adapted for deviating temperatures.

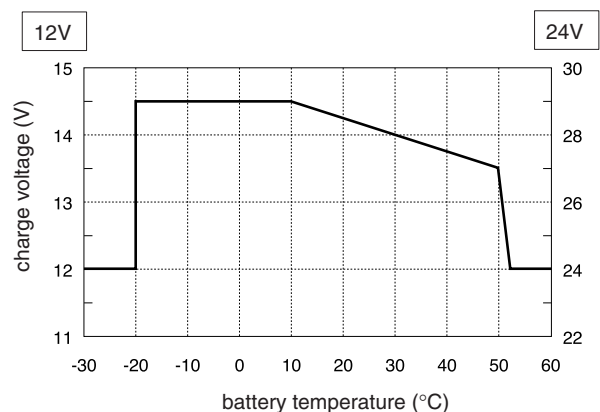

Figure 5:
Temperature compensated charging

See figure 5. When the battery temperature is low, the charge voltage increases. On the other hand, when the battery temperature is high, the charge voltage is decreased. Over charge and gassing are prevented this way. This will extend the life of your batteries.

3.4.2 Connection of a second and third battery

The Chargemaster is equipped with a second and a third charge output which can be used to give a maintenance charge to small battery sets like a starter battery. Maximum output current: 10 Amps ($\pm 10\%$). Output voltage: same as the main charger. See section 4.6 for connection.

3.5 HISTORICAL DATA

Press INFO shortly to scroll through the levels as described below. When no button is touched during 20 seconds, or if you hold SOURCE pressed for at least two seconds, the display returns to the initial readings.



See section 5.2 if you want to reset the below mentioned historical data.

CPLC
CYCL

Number of completed cycles

Total number charging cycles that were entirely completed, i.e. from bulk to float. See section 3.4 for detailed information of the three step charge algorithm.

ABOR
CYCL

Number of aborted cycles

Each time the charge cycle was not entirely finished, this counter is increased by 1. Operation of the Chargemaster might be interrupted because of AC grid failure. A large number of aborted cycles may indicate too short charging periods or an undersized charging system. Be aware that incomplete charges can reduce the expected lifetime of your batteries dramatically.

tot
Ah

Total Ampere hours charged

Total amount of charged Amphours or kAh for battery bank 1, 2 or 3 (press SOURCE to select the battery bank).

tot
RUN

Total runtime in charger mode

Total number of hours that the Chargemaster was charging.

HIGH
AC

Highest AC input voltage

Here the highest recorded AC input voltage is shown. To avoid damaging the charger this value may never be higher than the absolute maximum AC-input voltage (see figure 9). High AC-input voltages are often caused by generator sets that have a poor voltage regulation. Have your electrical installation examined by a qualified installer if this value is higher than 260VAC.

TEMP
SD

Number of temperature shutdowns

If the internal temperature of the Chargemaster is too high, it shuts down automatically. After cooling down, the Chargemaster will switch on again. A large number of temperature shutdowns might indicate too hot environmental conditions or bad cooling due to obstruction of the air flow around the charger.

LOW
DC

Number of low DC voltage shutdowns

If the battery voltage is too low the *ChargeMaster* will limit the charge current to 25% of the nominal charge current (see specifications). This counter shows the number of times that this happened. Have your electrical installation examined by a qualified installer if this has happened more than once.

HIGH
DC

Number of high DC voltage shutdowns

Also if the battery voltage is too high the *ChargeMaster* shuts down automatically. This counter shows the number of times that this happened. Have your electrical installation examined by a qualified installer if this has happened more than once.

HIGH
AC

Number of high AC voltage shutdowns

This value shows the number of times that the Chargemaster was shut off due to too high AC input voltage. High AC-input voltages are often caused by generator sets that have a poor voltage regulation. Have your electrical installation examined by a qualified installer if this has happened more than once.

LOW
AC

Number of low AC voltage shutdowns

Number of times that the Chargemaster was shut off due to too low AC input voltage (see figure 9). Low AC-input voltages may be caused by generator sets that have a poor voltage regulation or by thin AC-wiring. In some marinas or camping sites the AC power supply sometimes drops too low when there is a large demand of electric power.

LOW
DC

Lowest detected DC voltage

Shows the lowest DC-voltage that was recorded for battery bank 1, 2 or 3 (press SOURCE to select the battery bank). This value should never be below the final discharge voltage as specified by the battery manufacturer.

HIGH
DC

Highest detected DC-voltage

Shows the highest DC-voltage that was recorded for battery bank 1, 2 or 3 (press SOURCE to select the battery bank) This voltage should never be higher than the maximum charging voltage as specified by the battery manufacturer. Too high voltages may also damage the connected DC-loads.

SOFTWARE

Software version

Version of the installed software.

LOCK

Lock - Unlock

To protect the *ChargeMaster* against unintended adjustment of set points, the lock mode is activated every time you leave the Settings menu. When activated ("ON"), it is not possible to change settings.
Default setting: ON
Press SOURCE to toggle the lock mode.

3.6 MASTERBUS (OPTIONAL)

The Chagemaster is compatible with the MasterBus network: a fully decentralized data network for communication between the different Mastervolt system devices such as the inverter, battery charger, generator, batteries and many more. See chapter 6 for details.

3.7 MAINTENANCE

No specific maintenance to the Chagemaster is required. Examine your electrical installation on a regular base, at least once a year. Defects such as loose connections, burnt wiring etc. must be corrected immediately. If necessary, use a soft clean cloth to clean cabinet of the Chagemaster. Never use any liquids, acids and/or scourers.

3.8 FAILURES

The Chagemaster is protected against overload, short circuit, over heating and under and over voltage. If a fault condition occurs, text FAILURE is shown on the LCD-display. The cause of the failure is displayed by means of an error code. See section 7.2 for explanation.

**CAUTION!**

The Chagemaster is not protected against reversing polarity of the DC-output and serious over voltage (>265VAC) on the AC-input .



As long as FAILURE isn't shown, no failure is detected: the Chagemaster is operating normally!

4 INSTALLATION

During installation and commissioning of the Chargemaster, the important safety instructions are applicable at all times. See chapter 2 of this manual.

4.1 UNPACKING

In addition to the Chargemaster the delivery includes:

- A mounting bracket to mount the chargemaster to a wall;
- a battery temperature sensor;
- a MasterBus terminating device (see chapter 6);
- a cable gland for UL-compliant AC-connection (see section 4.4);
- this user's manual.

After unpacking, check the contents for possible damage. If in doubt, contact your supplier.

Check from the identification label (see section 1.4) whether the battery voltage is the same as the nominal output voltage of the Chargemaster (e.g. 24V battery set for a 24V battery charger).

4.2 ENVIRONMENT

Obey the following stipulations during installation:

- The Chargemaster is designed for indoor use only.
- Ambient temperature: 0 ... 60°C / 32°F ... 140°F; (power derating above 40°C / 104°F to decrease the internal heat sink temperature).
- Humidity: 0-95% non condensing
- Mount the Chargemaster vertically, with the connecting cables downwards.
- Make sure that the hot air that is developed during operation can be discharged. The Chargemaster must be mounted in such a way that obstruction of the airflow through the ventilation openings will be prevented.
- No objects must be located within a distance of 10 cm / 4 inch around the Chargemaster.
- Do not locate the Chargemaster in the same compartment as the batteries.
- Do not install the Chargemaster straight above the batteries because of possible corrosive sulphur fumes.

4.3 WIRING



WARNING!

The wire and fuse sizes stated in this manual are given as example only. Prescribed wire and fuse sizes may be different due to local applicable regulations and standards.

4.3.1 AC-wiring

For a safe installation the correct wire cross section must be applied. Don't use a cross section that is smaller than indicated. See table below to select the appropriate cross section for the AC wiring (up to 6m / 20ft length):

AC-Current	Minimum cross section:	
	in mm ²	AWG
6-12 Amp	1.5 mm ²	AWG 15
12-20 Amp	2.5 mm ²	AWG 13

Connection of AC-wiring and recommended wire colours

- 230V/50Hz installations:

Wire color	Meaning	Must be connected to:
Brown or black	Phase	L1
Blue	Neutral	N
Green/Yellow	Earth	PE / GND

- 120V/60Hz installations (single phase):

Wire color	Meaning	Must be connected to:
Black	Hot or Line	L1
White	Neutral	N
Green	Ground	PE / GND

- 240V/60Hz installations (dual phase 2x120VAC):

Wire color	Meaning	Must be connected to:
Black	Hot or Line	L1
Red	Hot or Line	L2
Green	Ground	PE / GND

4.3.2 DC wiring

Keep in mind that high current will pass through the DC wiring. Keep the cable length as short as possible, this will keep the system efficiency as high as possible. The recommended minimum cross section of the battery cables is:

- Main charge output (output 1)

Model Chargemaster	DC Cable cross section:	
	<3m / 10ft	3-5m / 10ft
12/70-3	25mm ² / AWG3	35mm ² / AWG2
12/100-3	35mm ² / AWG2	50mm ² / AWG0
24/40-3	16mm ² / AWG5	25mm ² / AWG3
24/60-3	25mm ² / AWG3	35mm ² / AWG2
24/80-3	35mm ² / AWG2	50mm ² / AWG0
24/100-3	35mm ² / AWG2	50mm ² / AWG0

- Charge output (output 2 and 3)

Model Chargemaster	DC Cable cross section:	
	<3m / 10ft	3-5m / 10ft
All models	4mm ² / AWG11	6mm ² / AWG9

Use ring terminals on the ends of the wires. The terminals must be crimped with a proper crimping tool. Use the following wire colours for DC wiring colour or at least different colours to make a clear distinction between the positive and negative wire from the battery:

Wire color	Meaning	Must be connected to:
Red	Positive	+ (POS)
Black	Negative	- (NEG)

Lay the positive and negative cables next to each other to limit the electro magnetic field around the cables. The negative cable should be connected directly to the negative post of the battery bank or the ground side of a current shunt. Do not use the chassis frame as the negative conductor. Tighten securely. The positive battery cable must be fused and connected to the positive post of the battery bank.

- Main charge output (output 1)

Model Chargemaster	Recommended charger fuse
12/70-3	80A
12/100-3	125A
24/40-3	50A
24/60-3	80A
24/80-3	100A
24/100-3	125A

- Charge output (output 2 and 3)

Model Chargemaster	Recommended charger fuse
All models	16A

The fuse with the fuse-holder is available from your local Mastervolt distributor or Customer Service Representative.

4.3.3 Battery capacity

The minimum required battery capacity is as follows:

Model Chargemaster	Minimum required battery capacity
12/70-3	140Ah
12/100-3	200Ah
24/40-3	80Ah
24/60-3	120Ah
24/80-3	160Ah
24/100-3	200Ah

4.3.4 AC safety grounding



WARNING!

The ground wire offers protection only if the cabinet of the Chargemaster is connected to the safety ground. Connect the ground terminal (PE / GND) to the hull or the chassis.



CAUTION!

For safe installation it is necessary to Insert a Residual Current Device (earth leakage switch) in the AC input circuit of the Chargemaster.

4.4 OVERVIEW CONNECTION COMPARTMENT

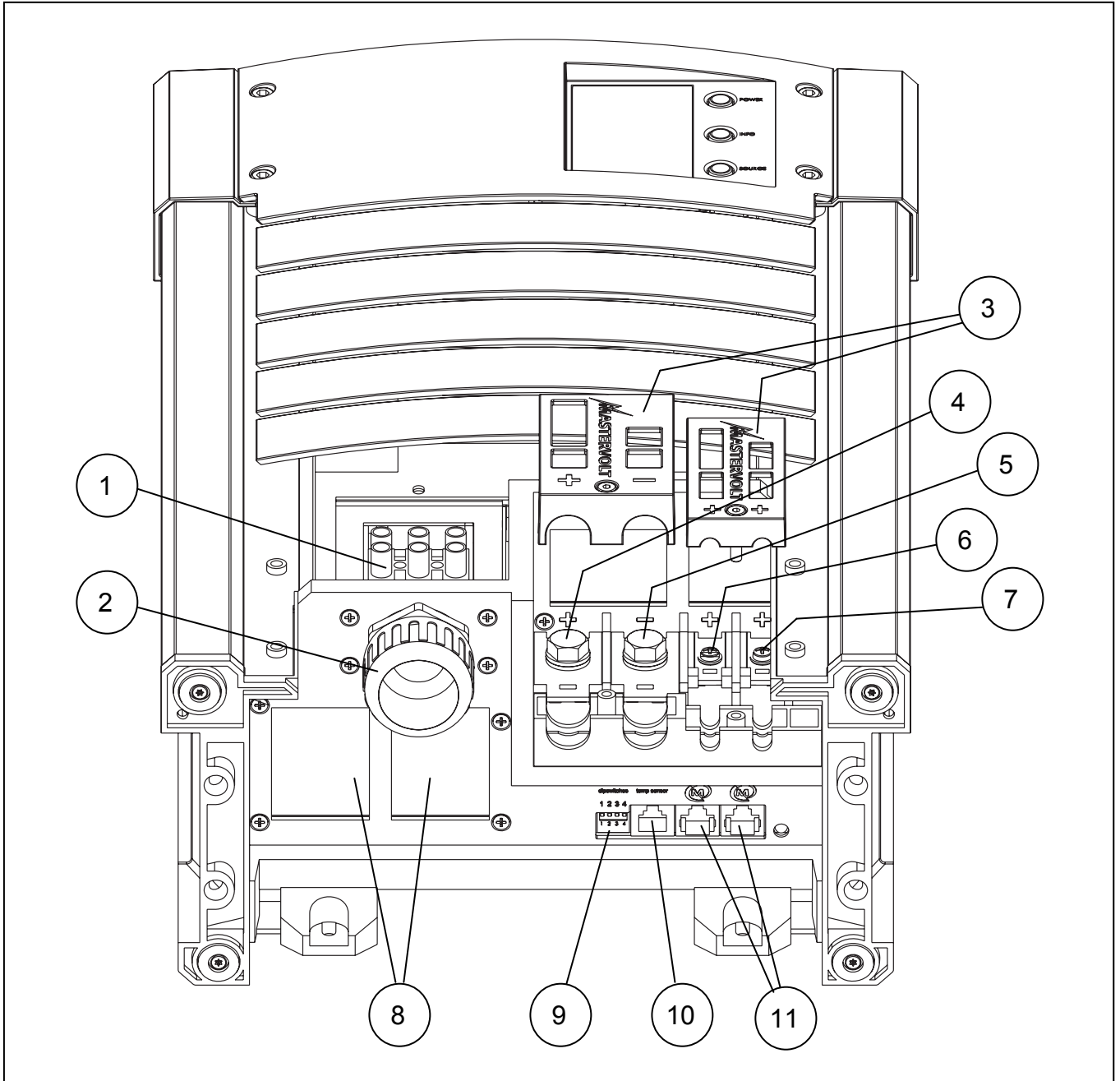

- 1 Screw terminals AC input
- 2 Cable gland for AC-wiring
- 3 Isolation caps for DC connections
- 4 Positive terminal charge output 1 (main output)
- 5 Common negative output terminal
- 6 Positive terminal charge output 2
- 7 Positive terminal charge output 3
- 8 Ventilation openings
- 9 DIP-switches
- 10 Temperature sensor jack
- 11 MasterBus connector

Figure 6: overview connection compartment

4.5 THINGS YOU NEED

Make sure you have all the parts you need to install the Chargemaster:

	Quantity
Chargemaster (included)	1
Battery temperature sensor with cable and plug (included).	1
DC-cable to connect the positive DC connection (+) of the Chargemaster to the positive pole of the DC-distribution; for specifications see section 4.3.2,	1
DC-cable to connect the negative DC connection (-) of the Chargemaster to the negative pole of the DC-distribution; for specifications see section 4.3.2.	1
DC-fuse holder with a DC-fuse, to be integrated in the positive DC-cable. For specifications see section 4.3.2.	1
Screws / bolts (Ø 6mm) (with plugs) to mount the cabinet to a surface. Use mounting materials which are suitable to carry the weight of the Chargemaster	4
AC cable* to connect the AC input to an external power source (e.g. a shore connection or a generator set);	1
Batteries. See section 4.3.3 for recommended capacity	X
Appropriate and reliable cable terminals, cable lugs, battery terminals and cord end terminals	X

* Double insulated three wire cable with wire colours according to the locally applicable regulations. The applicable length and wire diameter depend on the electrical installation (see section 4.3.1).

We recommend as a minimum tool kit:

- Socket wrench 13mm to fix the DC-input (battery) cables
- Flat blade screw driver 1.0 x 4.0 mm to fix the screw terminals
- Tools to fix the screws / bolts (Ø 6mm) with plugs to mount the cabinets to a surface
- Philips screw driver to open the connection area of the Chargemaster

4.6 CONNECTION



WARNING

Let installation work be done by a licensed electrician. Before beginning with the connection of the wiring, make the AC distribution as well as the DC distribution voltage free.



CAUTION!

Short circuiting or reversing polarity may lead to serious damage to the batteries, the Chargemaster, the cabling and/or the terminal connections. Fuses between the batteries and the Chargemaster can not prevent damage caused by reversed polarity. The damage as a result of reverse polarity is detectable by the service department and is not covered by the warranty.



CAUTION!

Too-thin cables and/or loose connections can cause dangerous overheating of the cables and/or terminals. Therefore tighten all connections well, in order to limit transition resistance as far as possible. Use cables of the correct size.



NOTE:

If the battery temperature remains within 15-25°C, connection of the battery temperature sensor is optional.



NOTE:

The Chargemaster is only feasible for the connection of MasterBus compatible remote control panels.

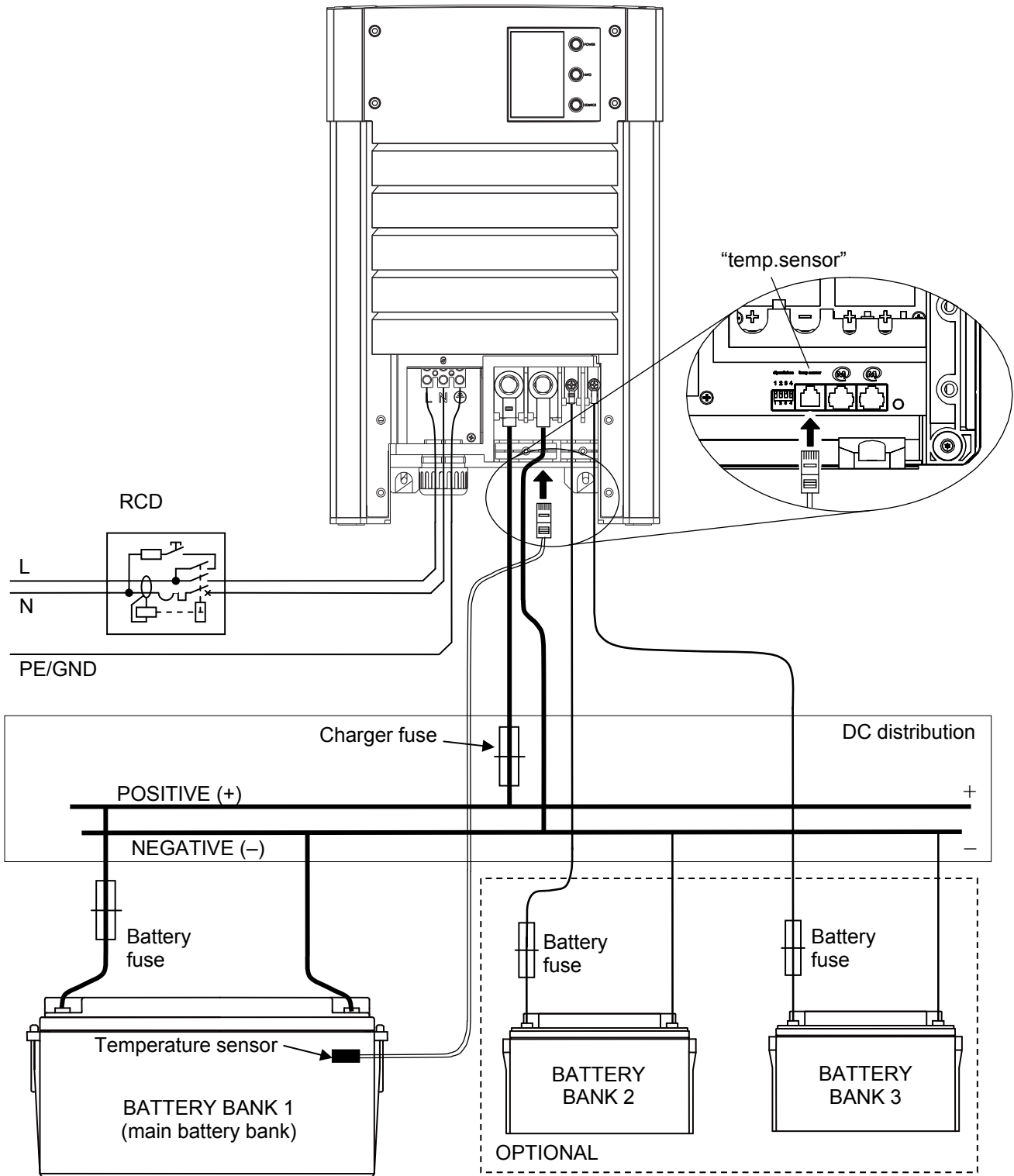

This schematic is to illustrate the general placement of the Chargemaster in a circuit. It is not meant to provide detailed wiring instructions for any particular electrical installation.

Figure 7: installation drawing of the Chargemaster

4.7 INSTALLATION STEP-BY-STEP

1 Mark the position of the mounting spots by using the mounting bracket. Then Fix the mounting bracket to the wall.

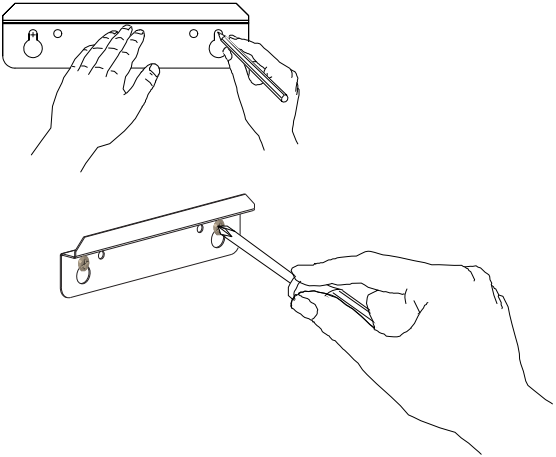

2 Place the ChargeMaster over the mounting bracket and then move it downwards until it is suspended from the mounting bracket.

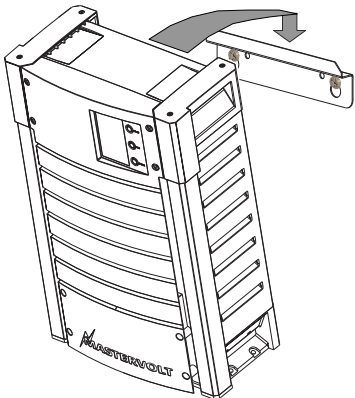

3 Fix the cabinet to the wall by fastening two screws at the lower side of the cabinet as well.

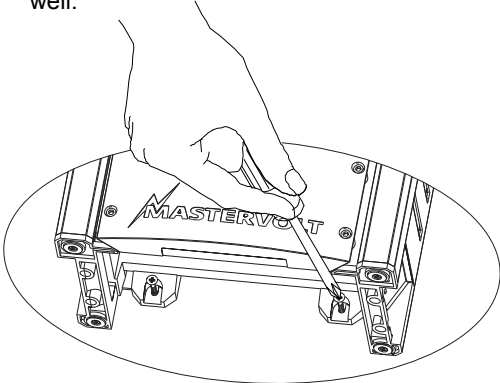

4 Open the connection compartment by loosening the four screws.

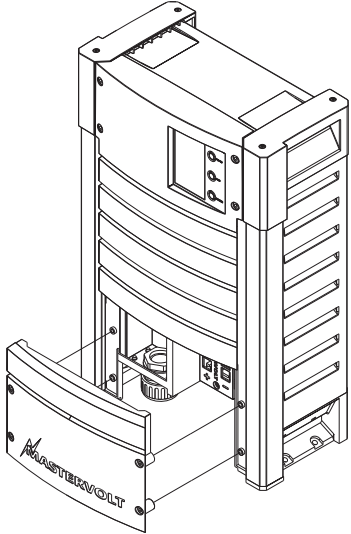

5 Feed the AC wiring through cable gland and connect the wiring to the screw terminals. Tighten the cable gland firmly.

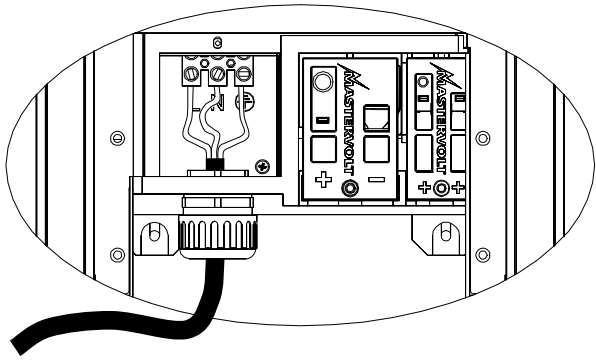

6 Remove the isolation cap from the DC terminals. Attach crimp-on ring terminals to both DC-cables. Connect the DC-cabling of battery bank 1, positive to +, negative to - .

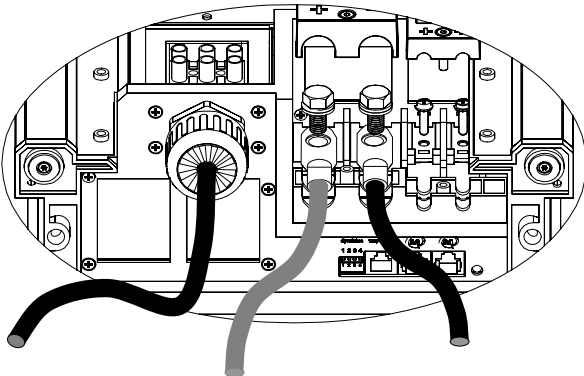

7 Option: Connect the DC-wiring of the second and third battery bank. These battery banks should have a common negative with the main battery (see figure 7).

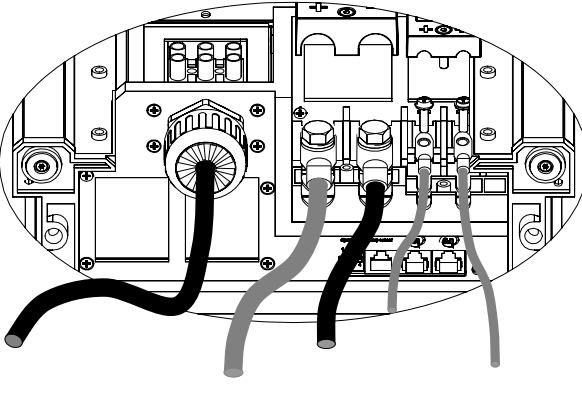

8 Attach the battery temperature sensor to the casing of battery bank 1. Plug the temperature sensor cable into the "temp.sensor" jack.

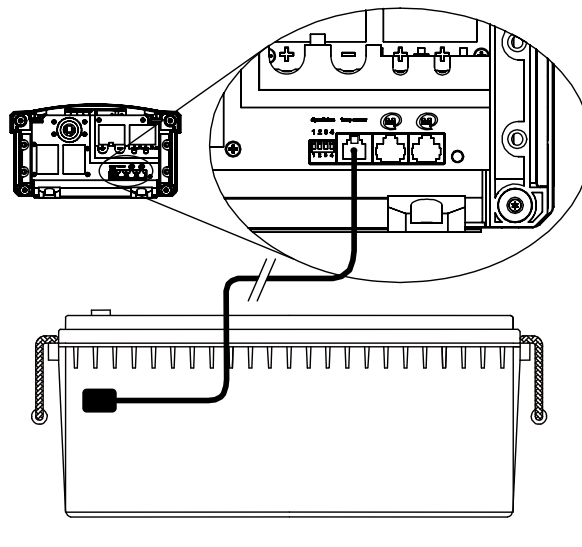

9 Option: Connect the ChargeMaster to the MasterBus network. See chapter 6.

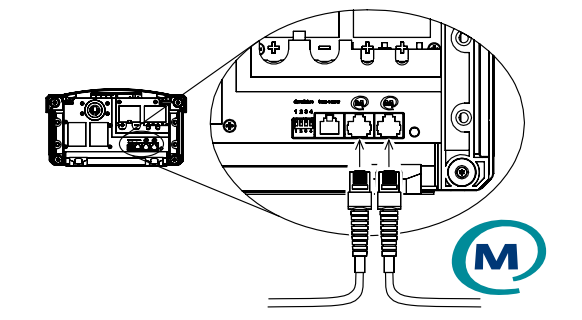

10 The factory setting of the ChargeMaster is optimal for most installations. In some applications however, it is desirable to change these settings. See section 5.1 for adjustment.
Use a small screw driver for adjustment of the DIP-switches.

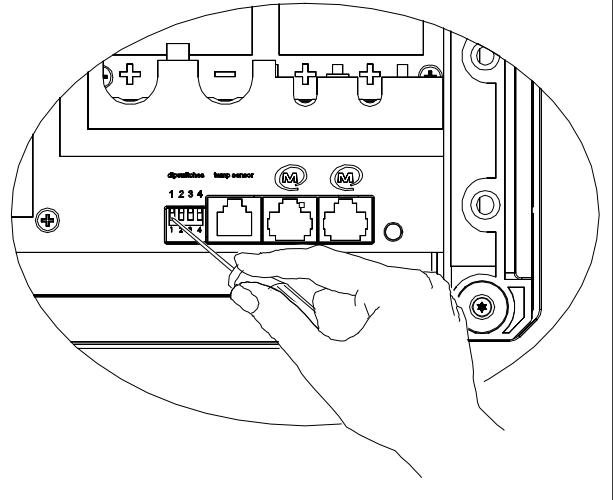

11 Check all wiring; see also figure 7 for wiring details.

12 Close the connection compartment by fixing the four screws.

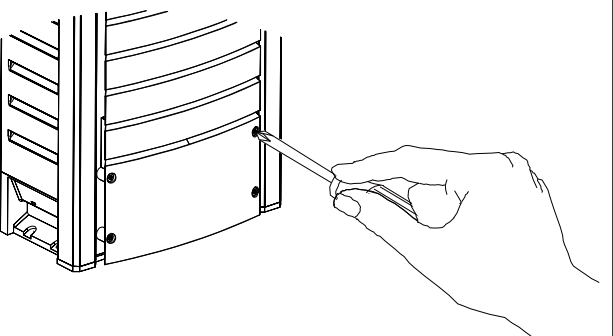

13 Continue with section 4.8 for commissioning of the ChargeMaster.

4.8 COMMISSIONING AFTER INSTALLATION



When your ChargeMaster is not new, you have to take into account that former users may have changed the settings. Reset the ChargeMaster back to factory settings when there is any doubt (see section 5.2).

4.8.1 General

The factory settings of the ChargeMaster are optimal for most installations. With some applications however, it is desirable to change these settings. Therefore several adjustments can be made. See chapter 5.



NOTE:

The DIP-switches must be adjusted *prior* to commissioning; all other settings can only be made *after* commissioning.



CAUTION!

Check the polarity of all wiring before commissioning: positive connected to positive (red cables), negative connected to negative (black cables).

If all wiring is OK, place the DC-fuse(s) of the DC-distribution to connect the batteries to the ChargeMaster.



WARNING

When placing this fuse, a spark can occur, caused by the capacitors used in the ChargeMaster. This is particularly dangerous in places with insufficient ventilation, due to the gassing of the batteries an explosion can occur. Avoid having flammable materials close by.

Now the ChargeMaster is ready for operation. After switching on the AC power supply the ChargeMaster will initiate the charging process.

4.8.2 MasterBus (optional)

During first commissioning the ChargeMaster will be recognized by the MasterBus network automatically. The remote control panel of the MasterBus network will indicate that a new device was found.

Some settings can only be changed via the MasterBus interface. See section 6.3 for an overview of all available MasterBus settings. Refer to the user's manual of the remote control panel to change these settings.

4.9 DECOMMISSIONING

If it is necessary to put the ChargeMaster out of operation, follow the instructions in order of succession as described below:

- 1 Switch the ChargeMaster to stand-by (see section 3.2).
- 2 Remove the DC-fuse(s) of the DC-distribution and/or disconnect the batteries.
- 3 Remove the AC-fuse(s) of the AC-input and/or disconnect the AC-mains.
- 4 Open the connection compartment of the ChargeMaster.
- 5 Check with a suitable voltage meter whether the inputs and the outputs of the ChargeMaster are voltage free.
- 6 Disconnect all the wiring.

Now the ChargeMaster can be demounted in a safe way.

4.10 STORAGE AND TRANSPORTATION

When not installed, store the ChargeMaster in the original packing, in a dry and dust free environment.

Always use the original packing for transportation. Contact your local Mastervolt Service Centre for further details if you want to return the apparatus for repair.

4.11 RE-INSTALLATION

To reinstall the ChargeMaster, follow the instructions as described in this chapter (chapter 4).

5 SETTINGS

Adjustment of the settings of the ChargeMaster can be made in three different ways:

- By means of DIP-switches; see section 5.1;
- By means of settings at the LCD-display; see section 5.2;
- Via the MasterBus network (by means of a remote control panel or an interface connected to a PC with MasterAdjust software); see section 6.3.



CAUTION!

Invalid settings of the ChargeMaster can cause serious damage to your batteries and/or the connected load! Adjustments of settings may be undertaken by authorised personnel only.

5.1 DIP SWITCH SETTINGS

The ChargeMaster has four DIP switches at the bottom side of the housing. See figure 8.

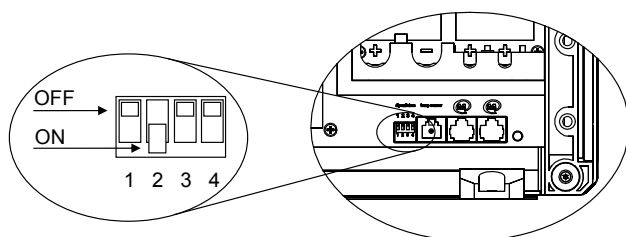

Figure 8: DIP-switches

5.1.1 DIP-switch 1: Battery type

The factory default for the battery type is optimal for most installations. In some applications however, it is desirable to change this setting.

Standard open lead/acid battery (factory setting)	OFF
Gel / AGM / spirial battery (see specifications)	ON

5.1.2 DIP switch 2: Charge algorithm

IUoUo, fully automatic / 3step+ (factory setting)	OFF
Constant voltage charging (Float = 13.25/26.5V)	ON

5.1.3 DIP-switch 3:Stand-by mode for display

By default the LCD-display will switch off after 2 minutes if either the Chargemaster is switched to Stand-by or the AC power supply is disconnected.

LCD-display will switch off when Chargemaster is switched to stand-by mode (factory setting) OFF

LCD-display will stay on when Chargemaster is switched to stand-by mode. Note that the LCD-display is powered by the batteries. ON

5.1.4 DIP switch 4: Equalize mode



WARNING

Incorrect use of the equalize mode may lead to hazardous situations.

Do not smoke; use any naked flame or other sources of ignition due to risk of explosion. Always ventilate the room were the batteries are located and equalized to clear the air.

Equalization is ONLY applicable for wet type batteries and will damage gel and AGM type batteries.

An equalizing charge can be necessary after very deep discharges and/or inadequate charges. This has to be carried out according to the specifications of the manufacturer of the batteries.

During equalizing the batteries are brought into the gas state and is it possible that the permitted load voltages are exceeded. Therefore appropriate measures must be taken, e.g. disconnect all loads from the battery and ventilate the room. For these reasons use of the equalizing mode should only be executed by trained technical engineers.

The equalizing mode can only be started when the Chargemaster is in operation and in Float. This means that the connection compartment of the Chargemaster must be opened while connected to the mains and the batteries. Take adequate measures for protection against short circuits and electrical shocks.

To start the equalize mode: move DIP switch 4 to the ON postion and back to the OFF position.

5.2 SETTINGS AT THE LCD-DISPLAY

- Hold SOURCE pressed for three seconds to get access to the settings menu.
- Then press SOURCE repeatedly to scroll through the settings menu as described below.
- To change a displayed setting, press INFO repeatedly. Hold INFO pressed for three seconds to switch between increasing/ decreasing a value. When the correct value is set, continue scrolling through the levels by pressing SOURCE repeatedly.



When no button is touched during 2 minutes, the display returns to the initial readings (section 3.3).



To protect the ChargeMaster against unintended adjustment of set points, the lock mode must be disabled before changing a setting. See section 3.5 (“Lock - Unlock”) to disable the lock mode.

5.2.1 Settings menu for models 12/70-3 and 12/100-3

Display Stage	Display Text	Setting	min	default	max	unit	resolution
BULK	BULK VOLT	Bulk voltage	0.00	14.40	15.50	V	0.05
BULK	MAX TMR	Maximum bulk timer	0	8h	24h	h / min	1min
BULK	MIN TMR	Minimum bulk timer	0	120sec	240sec	sec	1sec
ABS	ABS VOLT	Absorption voltage	0.00	14.25	15.50	V	0.05
ABS	MAX TMR	Max. absorption timer	0	4h	24h	h / min	1min
ABS	MIN TMR	Min absorption timer	0	15min	240min	h / min	1min
ABS	RET AMP	Return amps (% of maximum charge current)	0%	6%	50%	%	1%
ABS	RET AMP	Return amps timer	0	30sec	240sec	sec	1sec
FLOAT	FLT VOLT	Float voltage	0.00	13.25	15.50	V	0.05
FLOAT	CONST FLT	Forced float voltage (Constant voltage charging)	0.00	13.25	15.50	V	0.05
	RET BULK	Return to bulk voltage	0.00	12.80	15.50	V	0.05
	RET BULK	Return to bulk time delay	0	30sec	240sec	sec	1sec
	MAX CURR	Maximum charge current	0	nominal	nominal	A	1A
	ALM DEL	Alarm delay time	0	30sec	240	sec	1sec
	HIGH DCON	Alarm DC High on	0.00	16.00	16.00	V	0.05
	HIGH DCOF	Alarm DC High off	0.00	15.00	16.00	V	0.05
	LOW DCON	Alarm DC low on	0.00	10.00	16.00	V	0.05
	LOW DCOF	Alarm DC low off	0.00	11.00	16.00	V	0.05
	RES FACT	Reset to factory settings		NO			YES

5.2.2 Settings menu for models 24/40-3, 24/60-3, 24/80-3 and 24/100-3

Display Stage	Display Text	Setting	min	default	max	unit	resolution
BULK	BULK VOLT	Bulk voltage	0.00	28.80	31.00	V	0.05
BULK	MAX TMR	Maximum bulk timer	0	8h	24h	h / min	1min
BULK	MIN TMR	Minimum bulk timer	0	120sec	240sec	sec	1sec
ABS	ABS VOLT	Absorption voltage	0.00	28.50	31.00	V	0.05
ABS	MAX TMR	Max. absorption timer	0	4h	24h	h / min	1min
ABS	MIN TMR	Min absorption timer	0	15min	240min	h / min	1min
ABS	RET AMP	Return amps (% of maximum charge current)	0%	6%	50%	%	1%
ABS	RET AMP	Return amps timer	0	30sec	240sec	sec	1sec
FLOAT	FLT VOLT	Float voltage	0.00	26.50	31.00	V	0.05
FLOAT	CONST FLT	Forced float voltage (Constant voltage charging)	0.00	26.50	31.00	V	0.05
	RET BULK	Return to bulk voltage	0.00	26.50	31.00	V	0.05
	RET BULK	Return to bulk time delay	0	30sec	240sec	sec	1sec
	MAX CURR	Maximum charge current	0	nominal	nominal	A	1A
	ALM DEL	Alarm delay time	0	30sec	240	sec	1sec
	HIGH DCON	Alarm DC High on	0.00	32.00	32.00	V	0.05
	HIGH DCOF	Alarm DC High off	0.00	30.00	32.00	V	0.05
	LOW DCON	Alarm DC low on	0.00	20.00	32.00	V	0.05
	LOW DCOF	Alarm DC low off	0.00	22.00	32.00	V	0.05
	RES FACT	Reset to factory settings		NO			YES

6 MASTERBUS

6.1 WHAT IS MASTERBUS?



All devices that are suitable for MasterBus are marked by the MasterBus symbol.

MasterBus is a fully decentralized data network for communication between the different Mastervolt system devices. It is a CAN-bus based communication network which has proven itself as a reliable bus-system in automotive applications. MasterBus is used as power management system for all connected devices, such as the inverter, battery charger, generator and many more. This gives the possibility for communication between the connected devices, for instance to start the generator when the batteries are low.

MasterBus reduces complexity of electrical systems by using UTP patch cables. All system components are simply chained together. Therefore each device is equipped with two MasterBus data ports. When two or more devices are connected to each other through these data ports, they form a local data network, called the

MasterBus. The results are a reduction of material costs as only a few electrical cables are needed and less installation time.

For central monitoring and control of the connected devices Mastervolt offers a wide range of panels which show full status information of your electrical system at a glance and a push of a button. Four different panels are available, from the small Mastervision compatible 120 x 65mm LCD screen up to the full colour MasterView System panel. All monitoring panels can be used for monitoring, control and configuration of all connected MasterBus equipment.

New devices can be added to the existing network in a very easy way by just extending the network. This gives the MasterBus network a high degree of flexibility for extended system configuration, not only today, but in the future as well!

Mastervolt also offers several interfaces, making even non-MasterBus devices suitable to operate in the MasterBus network.

6.2 HOW TO SET UP A MASTERBUS NETWORK

Each device that is suitable for the MasterBus network is equipped with two data ports. When two or more devices are connected to each other through these ports, they form a local data network, called the MasterBus.

Keep the following rules in mind:

Connections between the devices are made by standard straight UTP patch cables. Mastervolt can supply these cables. These cables are also commonly available at computer supply stores.

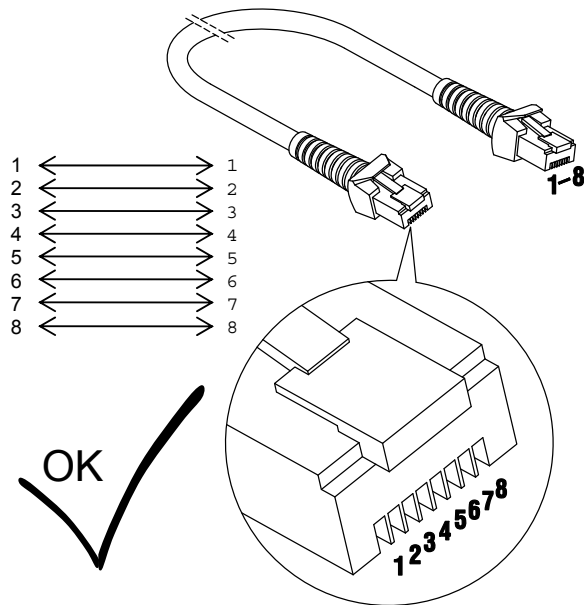

As with all high speed data networks, MasterBus needs a terminating device on both ends of the network.

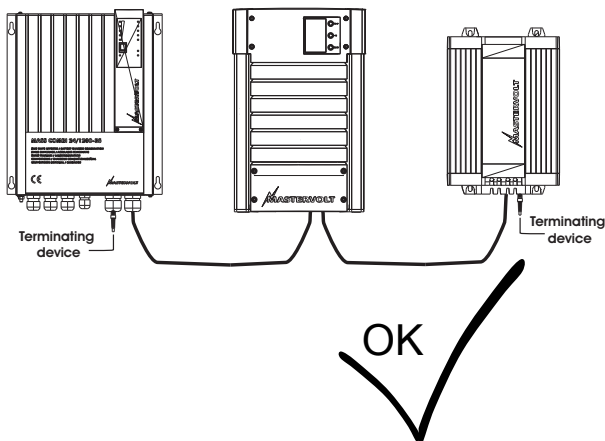

The electric power for the network comes from the connected devices.

At least one device in the network should have powering capabilities (see specifications).

One powering device can power up to three non-powering devices.

As all powering devices are galvanically isolated, multiple powering devices are allowed.

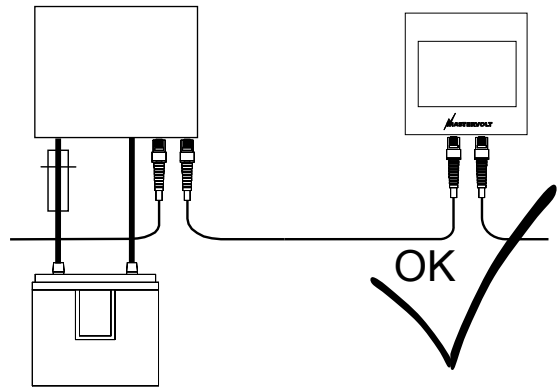

Do not make ring networks.

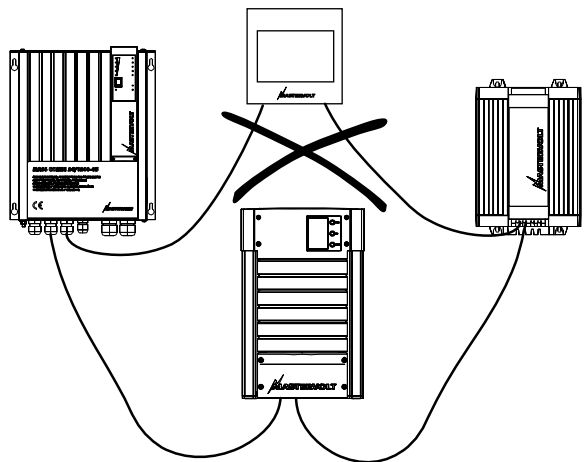

Do not make T-connections in the network.

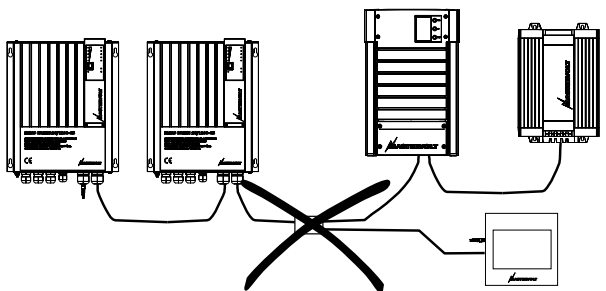

6.3 MASTERBUS: MONITORING AND PROGRAMMING OF THE CHARGEMASTER

6.3.1 Level 2: Monitoring

Value	Meaning	Default	Adjustable range
State of charger	State of charge algorithm: Bulk/absorption/float		(read only)
Voltage output 1	Voltage of charge output 1 (main output)*		(read only)
Current output 1	Current of charge output 1 (main output)*		(read only)
Voltage output 2	Voltage of charge output 2		(read only)
Current output 2	Current of charge output 2		(read only)
Voltage output 3	Voltage of charge output 3		(read only)
Current output 3	Current of charge output 3		(read only)

6.3.2 Level 3: Alarms

Value	Meaning	Factory setting	Adjustable range
Low batt	Battery voltage has dropped below setting <i>DC low on</i> , and has not increased above setting <i>DC low off yet</i>	See 6.3.4	See 6.3.4
High batt	Battery voltage has increased above setting <i>DC high on</i> , and has not dropped below setting <i>DC high off yet</i>	See 6.3.4	See 6.3.4
Low AC	AC input voltage is too low	90V / 180V*	n/a
High AC	AC input voltage is too high	135V / 265V*	n/a
Low frequency	AC input frequency is too low	45Hz	n/a
High frequency	AC input frequency input is too high	65Hz	n/a
High temperature	Internal temperature is too high	80°C (176°F)	n/a
Low temperature	Internal temperature is too low	-20°C (-4°F)	n/a

* see section 8.3, figure 9 for characteristics

6.3.3 Level 3: History

This menu shows the absolute maximum readings. See section 3.5 for detailed description.

Value	Meaning	Factory setting	Adjustable range
Completed charg.	Number of completed cycles		(read only)
Aborted charger.	Number of aborted charge cycles		(read only)
Ah charged	Total Ampere hours charged		(read only)
Total run time	Total run time in charger mode		(read only)
Highest AC volt	Highest AC input voltage		(read only)
Number of tempe.	Number of temperature shutdowns		(read only)
Number of low D	Number of low DC voltage shutdowns		(read only)
Number of High.	Number of high DC voltage shutdowns		(read only)
Number of High.	Number of high AC voltage shutdowns		(read only)
Number of low A	Number of low AC voltage shutdowns		(read only)
Output 1			
Lowest DC volta	Lowest detected DC voltage		(read only)
Highest DC volt	Highest detected DC voltage		(read only)
Software version	Software version		(read only)

6.3.4 Level 3: Configuration

Below parameters can be changed via the MasterBus network by means of a remote control panel or by means of an interface connected to a PC with MasterAdjust software. See applicable user's manuals for details.

Value	Meaning	Factory setting	Adjustable. range
Language	Language that is displayed on a monitoring device connected to the MasterBus	English	English
Bulk settings			
Bulk voltage	Bulk voltage	14.40/28.80V	0-15.50/0-31.00V
Max. bulk timer	Maximum bulk timer	8h	0-24h
Min bulk timer	Minimum bulk timer	120sec	0-240sec
Start bulk timer	Start bulk timer	13.25/26.50V	(read only)
Absorption settings			
Abs. voltage	Absorption voltage	14.40/28.80V	0-15.50/0-31.00V
Max absorption	Maximum absorption timer	4h	0-24h
Min absorption	Minimum absorption timer	15min	0-240min
Return amps	Return amps (% of maximum charge current)	6%	0-50%
Return amps tim	Return amps timer	30sec	0-240sec.
Float settings			
Float voltage	Float voltage	13.25/26.50V	0-15.50/0-31.00V
Forced float vo.	Forced float voltage (Constant voltage charging)	13.25/26.50V	0-15.50/0-31.00V
Return to bulk	Return to bulk voltage	13.25/26.50V	0-15.50/0-31.00V
Return to bulk	Return to bulk time delay	30sec	0-240sec
Max Charge curr	Maximum charge current	100%	0-100%
Alarm setpoints			
DC high on	Alarm DC High on	16.00/32.00V	0-16.00V0-32.00V
DC high off	Alarm DC High off	15.00/30.00V	0-16.00V0-32.00V
DC low on	Alarm DC low on	10.00/20.00V	0-16.00/0-32.00V
DC low off	Alarm DC low off	11.00/22.00V	0-16.00/0-32.00V
Alarm delay	Alarm delay time	30sec	0-240sec
Device settings			
Product name on.	Name of this device. This name will be recognized by all devices connected to the MasterBus	CHG CM+type*	0-12 chars
Traction settings			
Traction Bulk v	Traction bulk voltage	+300/+600mV	(read only)
Traction Absorpt	Traction absorption voltage	+300/+600mV	(read only)
Traction absorpt	Traction absorption timer	480 min	(read only)
Equalize settings			
Equalize voltage	Equalize voltage float	+2.25/+4.50V	(read only)
Max equalize tim	Max equalize timer	8h	(read only)
Fixed settings			
Temperature com	Temperature compensation for charge voltage	-30mV/°C -60mV/°C	(read only)
Max allowed upp	Maximum allowed upper temperature	+300/+600mV	(read only)
Max allowed low	Maximum allowed lower temperature	480 min	(read only)
Max voltage com	Maximum voltage compensation for temperature compensated charging,	+0.3/+0.6V	(read only)
AGM / GEL floa	AGM / GEL float voltage setting	+550/+1100mV	(read only)
Hardware settings			
Gel / AGM	DIP-switch 1: Battery type	(see section 5.1.1)	(read only)
Force float	DIP switch 2: Charge algorithm	(see section 5.1.2)	(read only)
Equalize	DIP switch 4: Equalize mode	(see section 5.1.4)	(read only)

Value	Meaning	Factory setting	Adjustable. range
Display on/off	DIP-switch 3:Stand-by mode for display	(see section 5.1.3)	(read only)
Charger	Switching on / stand-by	(see section 3.1)	(read only)
Art. nr	Shows the article number and the serial number of the		(read only)
Serial	Chargemaster		

* Depending on model: CM12/70, CM12/100, CM24/40, CM24/60, CM24/80 or CM24/100,

6.3.5 List of list of events sources

With this version of the *Chargemaster* programming of event commands is not possible.

6.3.6 List of list of event commands

With this version of the *Chargemaster* programming of event commands is not possible.

7 TROUBLE SHOOTING

If you cannot solve a problem with the aid of this chapter, contact your local Mastervolt Service Centre. See www.mastervolt.com. Make sure you have the following information present if you have to contact your local Mastervolt Service Center to solve a problem:

Article and serial number (See section 1.4)
 Software version (See section 3.5)

7.1 FAULT FINDING TABLE

Malfunction	Possible cause	What to do
No output voltage and/or current	No AC-input	Check AC wiring, check remote control panel.
	AC-input voltage too low (< 90VAC)	Check input voltage, check generator.
	AC input frequency out of range	Check input voltage, check generator.
Output voltage too low, charger supplies maximum current	Load that is connected to the batteries is larger than charger can supply.	Reduce load taken from the batteries.
	Batteries not 100% charged	Measure battery voltage. After some time this will be higher.
Charge current too low	Batteries almost fully charged	Nothing, this is normal when the battery is almost fully charged.
	High ambient temperature	Nothing; if ambient temperature is more than 40°C the charge current is automatically reduced.
	Low AC input voltage. At lower AC-input voltages the charge current is reduced. See figure 9	Check AC-input voltage.
Batteries not fully charged	Charge current too low	See "Charge current too low".
	Current to load is too high	Reduce load taken from the batteries.
	Charge time too short	Use a battery charger with higher capacity.
	Battery temperature too low	Use the battery temperature sensor.
	Defective or old battery	Check battery and replace if necessary.
Batteries are discharged too fast	Battery capacity reduced due to wastage or sulphation, stagnation	Charge and recharge a few times, this might help. Check battery and replace if necessary.
Batteries are too warm, gassing	Defective battery (short circuit in cell)	Check battery and replace if necessary.
	Battery temperature too high	Use the battery temperature sensor.
	Charge voltage too high	Check settings (see section 5.2).

7.2 FAULT INDICATION

If an error occurs, FAILURE is shown on the display. The origin of the error is displayed by means of an error code.

Error code	Explanation	What to do
INP FREQ	AC Input frequency too high or too low	Check AC frequency, check generator.
INP VOLT	AC Input voltage too high or too low	Check AC voltage, check generator.
HIGH VOLT	DC voltage too high	Check battery voltage.
LOW VOLT	DC voltage too low	Check battery voltage.
BATT LOW	DC voltage too low	Check battery voltage.
TMP SD	Temperature shutdown	Let the charger cool down. See also section 4.2.

8 TECHNICAL DATA

8.1 SPECIFICATIONS 12V MODELS

Model	12/70-3	12/100-3
Article no.	44010700	44011000
GENERAL		
Nominal input voltage**:	120/230V	120/230V
Nominal input frequency:	50/60Hz	50/60Hz
Full load consumption:	1200VA	1700VA
Max. AC input current (@ 230VAC)	7A	9A
Max. AC input current (@ 120VAC)	14A	18A
Nominal output voltage:	12V	12V
Total charge current*:	70A at 14.4V	100A at 14.4V
Number of battery outlets:	3	3
Max. current second output:	10A +/- 10%	10A +/- 10%
Max. current third output:	10A +/- 10%	10A +/- 10%
Charge characteristic*:	IUoUo, automatic, three step plus	
Charge voltage Bulk*:	14.4V	14.4V
Charge voltage Absorption*:	14.25V	14.25V
Charge voltage Float*;	13.25V	13.25V
Max. absorption and max. bulk timer*:	8 hours (start max. bulk timer at 13.25V)	
Minimum absorption time*:	15 min.	15 min.
Battery type settings*:	Open lead / gel / traction / AGM / spiral (adjustable by means of DIP-switch)	
Dimensions (mm):	362x277x150	362x277x150
Dimensions (inch):	14.3x11.0x5.9	14.3x11.0x5.9
Weight:	<7kg (<16Lbs)	<7kg (<16Lbs)
Recommended battery capacity:	160-800Ah	160-800Ah
Power factor regulations	≤ 0,98	≤ 0,98
Temperature compensation	Battery temperature sensor and cable included.	
Voltage compensation	Yes, by means of automatic compensation.	
DC consumption	<10mA	<10mA
Temperature range	-25°C (-13°F) to 60°C (140°F) derating 3%/°C (2%/°F) above 40°C (104°F) , 90% derating under 0°C (32°F)	
Cooling	Vario fan and natural cooling to ensure optimized cooling when unit stored in corners etc.	
Sound level	<52dBA / 1m	
Protection degree	IP23	IP23
Approvals	Fully CE and E-marking according to automotive directive 95/54/EG / UL pending	
MasterBus connectivity	Yes	Yes
Powering capabilities for MasterBus	Yes, when the charger is switched on, it can power up to three non-powering devices.	

* Adjustable, see chapter 5 for settings.

** See also figure 9.

Specifications are subject to change without prior notice.

8.2 SPECIFICATIONS 24V MODELS

Model	24/40-3	24/60-3	24/80-3	24/100-3
Article no.	44020400	44020600	44020800	44021000
GENERAL				
Nominal input voltage**:	120/230V	120/230V	120/230V	120/230V
Nominal input frequency:	50/60Hz	50/60Hz	50/60Hz	50/60Hz
Full load consumption	1400VA	2000VA	2700VA	3375VA
Max. AC input current (@ 230VAC)	8A	10A	13A	16A
Max. AC input current (@ 120VAC)	16A	20A	26A	32A
Nominal output voltage:	24V	24V	24V	24V
Total charge current*:	40A at 28.8V	60A at 28.8V	80A at 28.8V	100A at 28.8V
Number of battery outlets:	3	3	3	3
Max. current second output:	10A +/- 10%	10A +/- 10%	10A +/- 10%	10A +/- 10%
Max. current third output:	10A +/- 10%	10A +/- 10%	10A +/- 10%	10A +/- 10%
Charge characteristic*:	IUoUo, automatic, three step plus			
Charge voltage Bulk*:	28.8V	28.8V	28.8V	28.8V
Charge voltage Absorption*:	28.5V	28.5V	28.5V	28.5V
Charge voltage Float*;	26.5V	26.5V	26.5V	26.5V
Max. absorption and max. bulk timer*:	8 hours (start max. bulk timer at 26.5V)			
Minimum absorption time*:	15 min.	15 min.	15 min.	15 min.
Battery type settings*:	Open lead / gel / traction / AGM / spiral (adjustable by means of DIP-switch)			
Dimensions (mm):	362x277x150	362x277x150	432x277x150	432x277x150
Dimensions (inch):	14.3x11.0x5.9	14.3x11.0x5.9	17.0x11.0x5.9	17.0x11.0x5.9
Weight:	<7kg (<16Lbs)	<7kg (<16Lbs)	<8kg (<18Lbs)	<8kg (<18Lbs)
Recommended battery capacity:	100-500Ah	150-750Ah	200-1000Ah	200-1000Ah
Power factor regulations	≤ 0,98	≤ 0,98	≤ 0,98	≤ 0,98
Temperature compensation	Battery temperature sensor and cable included.			
Voltage compensation	Yes, by means of automatic compensation.			
DC consumption	<5mA	<5mA	<5mA	<5mA
Temperature range	-25°C (-13°F) to 60°C (140°F) derating 3%/°C (2%/°F) above 40°C (104°F), 90% derating under 0°C (32°F)			
Cooling	Vario fan and natural cooling to ensure optimized cooling when unit stored in corners etc.			
Sound level	<52dBA / 1m			
Protection degree	IP23	IP23	IP23	IP23
Approvals	Fully CE and E-marking according to automotive directive 95/54/EG / UL pending			
MasterBus connectivity	Yes	Yes	Yes	Yes
Powering capabilities for MasterBus	Yes, when the charger is switched on, it can power up to three non-powering devices.			

* Adjustable, see chapter 5 for settings

** See also figure 9

Specifications are subject to change without prior notice.

8.3 CHARACTERISTICS

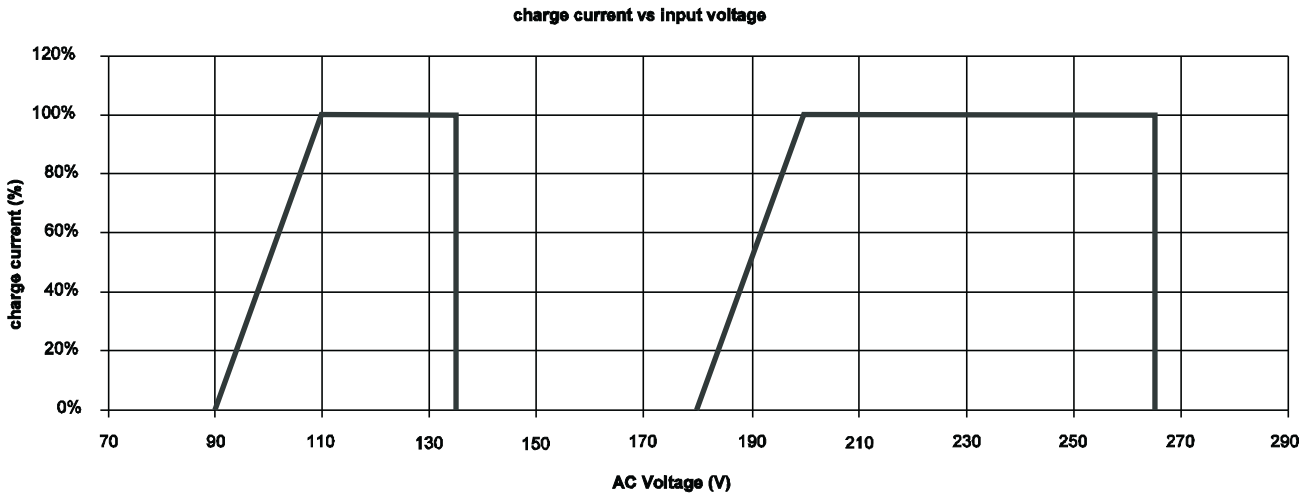

Figure 9: Charge current versus input voltage

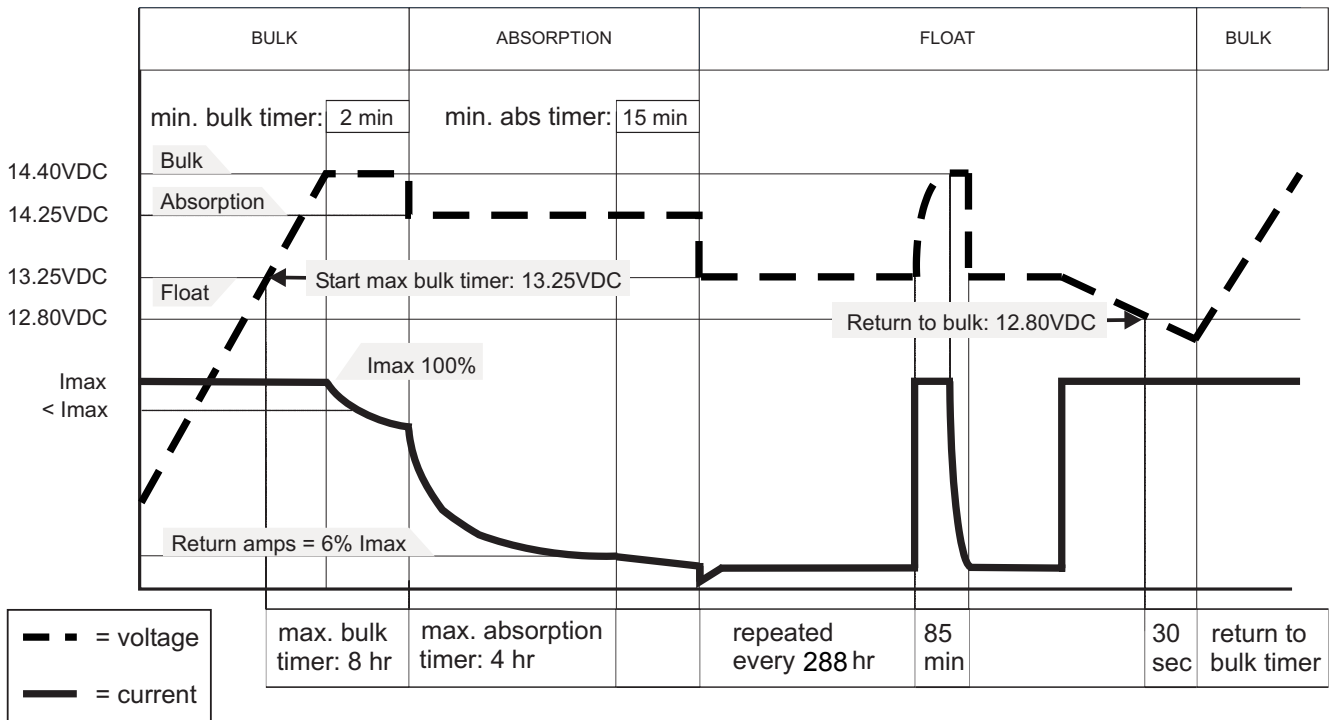

Figure 10: Charge characteristic of the three-step Plus charging method (at 25°C / 77°F)

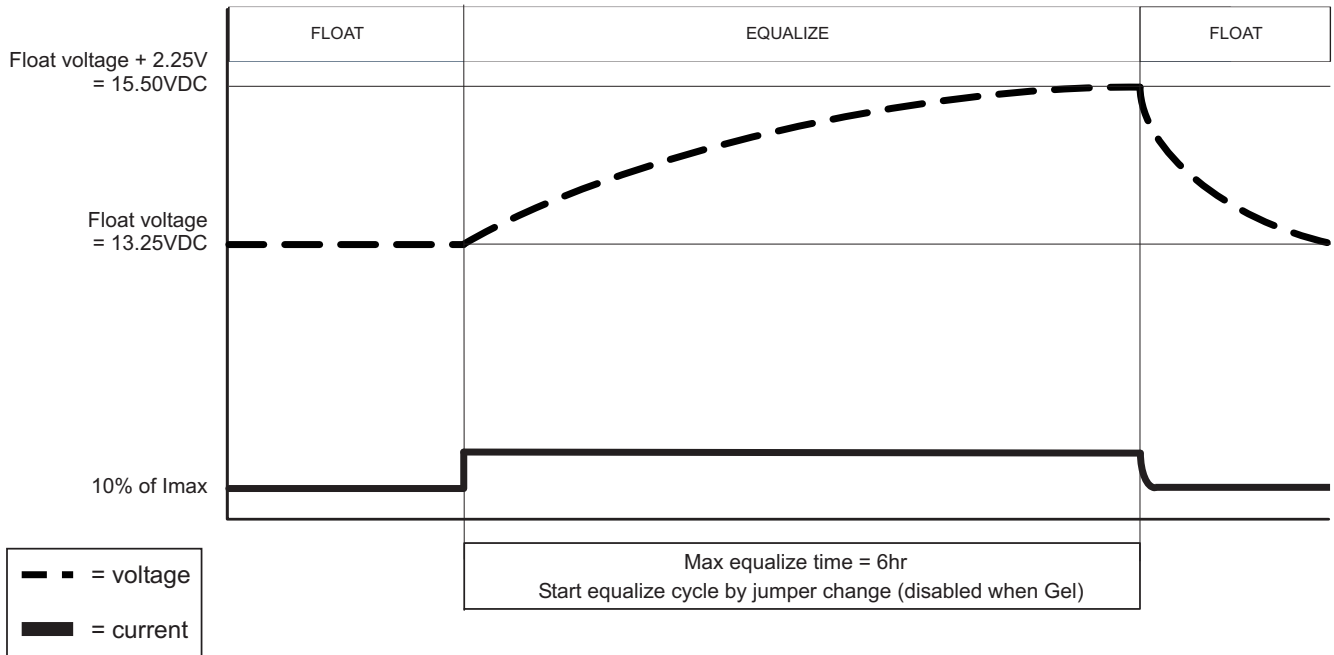

Figure 11: Charge characteristic of the equalize charge cycle (see section 5.1.4) (at 25°C / 77°F)

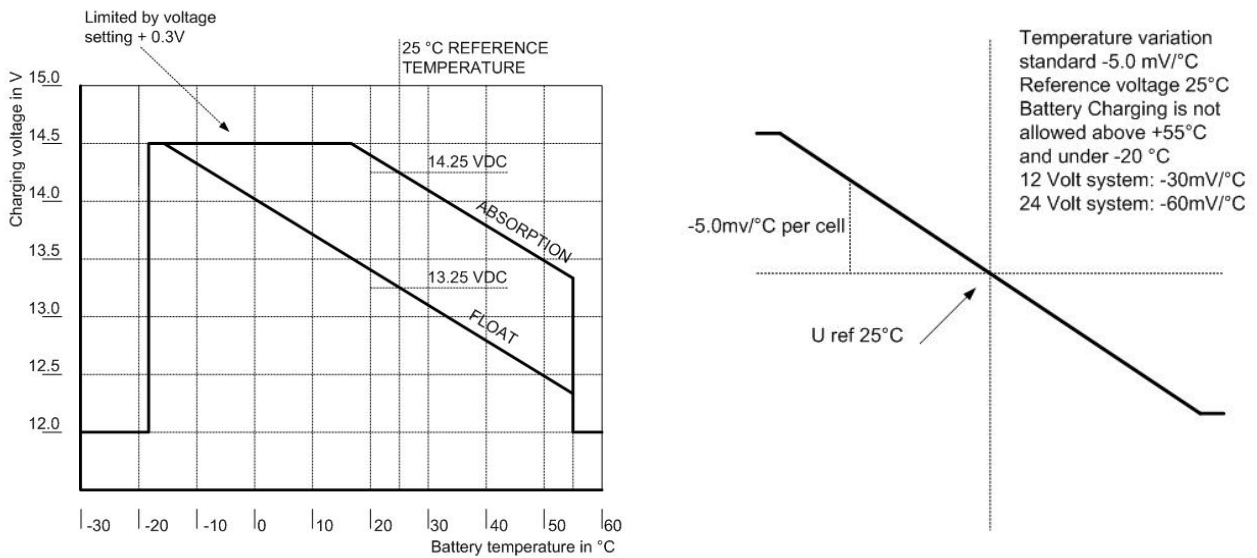

Figure 12: Temperature compensation characteristic (charge voltage versus temperature)

9 ORDERING INFORMATION

9.1 MASTERBUS INSTALLATION COMPONENTS

Part number	Description
77040000	MasterBus terminating device
77040020	MasterBus connection cable (UTP patch cable), 0,2m / 0.6ft
77040050	MasterBus connection cable (UTP patch cable), 0,5m / 1.6ft
77040100	MasterBus connection cable (UTP patch cable), 1,0m / 3.3ft
77040300	MasterBus connection cable (UTP patch cable), 3,0m / 10ft
77040600	MasterBus connection cable (UTP patch cable), 6,0m / 20ft
77041000	MasterBus connection cable (UTP patch cable), 10m / 33ft
77041500	MasterBus connection cable (UTP patch cable), 15m / 49ft
77042500	MasterBus connection cable (UTP patch cable), 25m / 82ft
77050000	100m / 330ft MasterBus cable (UTP cable)
77050000	50 pcs. modular jacks
77050000	Complete set to assemble UTP patch cables. Delivery includes: 100m / 330ft UTP cable, 50 pcs. modular jacks and crimping tool
77030100	MasterConnect USB interface, required as interface between your PC and the MasterBus when using MasterAdjust software.
77010100	MasterView Classic, Mastervision compatible display to control and monitor all MasterBus products
77010300	MasterView Easy, Touch screen to control and monitor all MasterBus products
77010400	MasterView System, Full-colour touch screen to control and monitor all MasterBus products
77020100	MasterShunt 500, DC-distribution module for exact readout of battery voltage, charge / discharge current, and state of charge on the display of the ChargeMaster. continuous rating: 250A, peak current: 500A

9.2 MISCELLANEOUS

Part number	Description
6384001600	Industrial DC fuse 16A DIN 00
6384005000	Industrial DC fuse 50A DIN 00
6384008000	Industrial DC fuse 80A DIN 00
6384010000	Industrial DC fuse 100A DIN 00
6384012500	Industrial DC fuse 125A DIN 00
6381001000	Fuse base DIN 00 (max. 160A)
79009006	Battery switch 250A with knob
79009005	Battery switch 250A with key
6387000600	Double pole automatic circuit breaker DPN 6A-B, 1P+N
6387001000	Double pole automatic circuit breaker DPN 10A-B, 1P+N
6387001600	Double pole automatic circuit breaker DPN 16A-B, 1P+N
6385401610	Double pole automatic circuit breaker and earth leakage switch DPN VIGI 16A / B / 16mA, 1P + N
41500500*	Battery temperature sensor, incl. 6 meter / 19 ft cable

* standard included with the delivery of the Chargemaster

MasterVolt can offer a wide range of products for your electrical installation, including an extended program of components for your MasterBus network, both AGM and gel batteries, shore power connections, DC distribution kits and many more. See our website www.mastervolt.com for an extensive overview of all our products.

10 EC DECLARATION OF CONFORMITY

Manufacturer Mastervolt
Address Snijdersbergweg 93
1105 AN Amsterdam
The Netherlands



Herewith declares that:

Product:

44010700	Chargemaster 12/70-3
44011000	Chargemaster 12/100-3
44020400	Chargemaster 24/40-3
44020600	Chargemaster 24/60-3
44020800	Chargemaster 24/80-3
44021000	Chargemaster 24/100-3

Is in conformity with the provision of the EC, EMC directive 89/336/EEC and amendments 92/31/EEC, 93/68/EEC

The following harmonized standards have been applied:

EN 60950-1
EN 55022: 1998+A1 : 2000+A2: 2003 Class A
EN 61000-4-2: 2001, EN 61000-4-4: 2004, EN 61000-4-5: 2001,
EN 61000-4-3: 2002+A1: 2002, EN 61000-4-6: 1996+A1: 2000
EN 61000-3-2: 2000, EN 61000-6-4: 1997

Amsterdam,



P.F. Kenninck,
General Manager MASTERVOLT



Snijdersbergweg 93, 1105 AN Amsterdam, The Netherlands

Tel : + 31-20-3422100

Fax : + 31-20-6971006

Email : info@mastervolt.com